

# **Recommendations to Estimate Swine Nutrient Generation in the Phase 6 Chesapeake Bay Program Watershed Model**

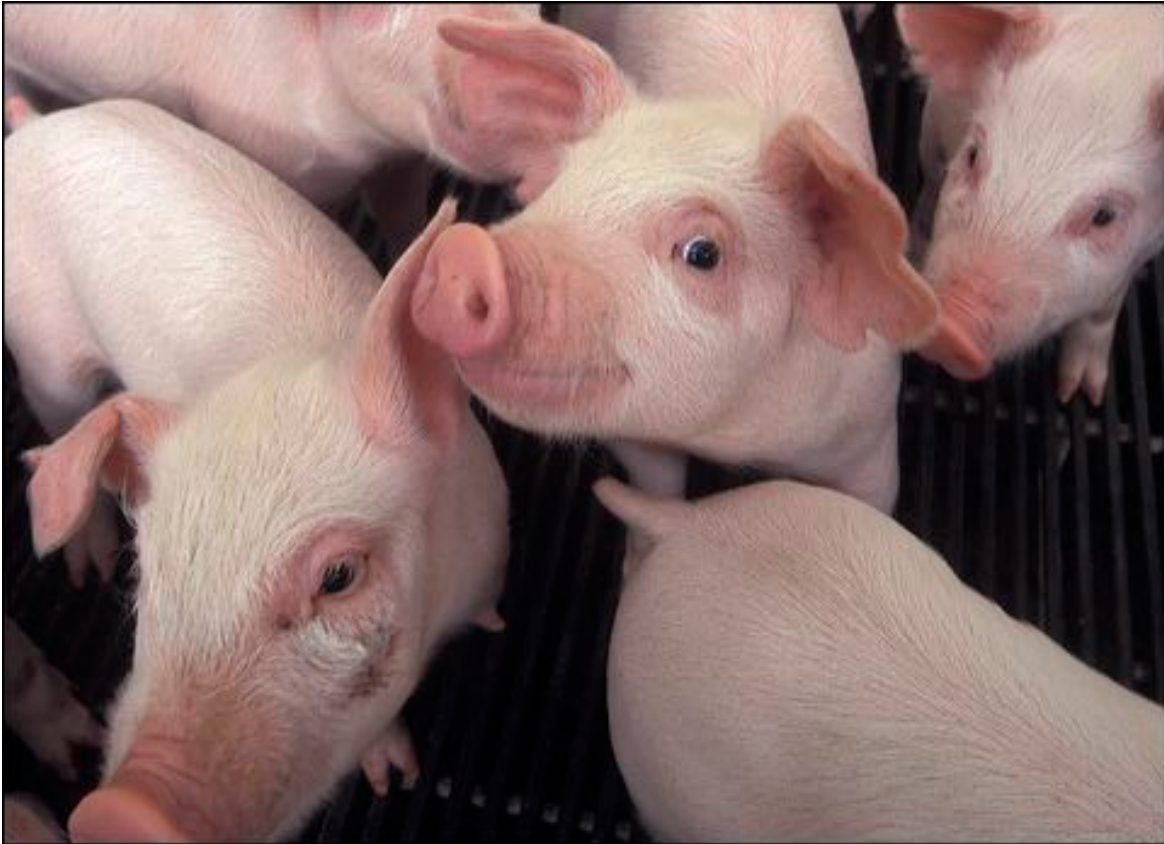

## **FINAL REPORT**

Recommendations for Approval by the Water Quality Goal  
Implementation Team's Agriculture Workgroup

**Submitted by the Commercial Swine Characterization Project Team**

**Submitted to:**  
Agriculture Workgroup  
Chesapeake Bay Program

December 18, 2016

## The Project Team

<b>NAME</b>	<b>AFFILIATION</b>	<b>ROLE</b>
Mark Estienne	Professor of Swine Reproduction, Virginia Tech	Project co-lead; data processing and analysis; report compilation and writing.
Robert Meinen	Senior Extension Associate, Penn State University	Project co-lead; data processing and analysis; report compilation and writing.
Jordan Kristoff	Intern; Virginia Tech	Data collection and processing
Timothy Sexton	Nutrient Management Program Manager, Virginia DCR	PA data collection. Provided oversight and QA/QC of data inputs and managed activities of intern.
Bobby Long	Nutrient Management Coordinator, Animal Waste, Virginia DCR	Provided historical swine manure characteristics data; data review and interpretation.
Mark Dubin	Chesapeake Bay Program	Agriculture Workgroup Coordinator

## Table of Contents

The Project Team .....	2
List of Tables .....	4
List of Figures .....	4
Abbreviations and Acronyms .....	5
1.0 Introduction .....	6
2.0 Goal and Scope .....	7
3.0 Materials and Methods .....	7
3.1 Description of Swine Production Systems .....	7
3.1.1 Sow Farms .....	8
3.1.2 Boar Studs .....	9
3.1.3 Nursery Farms .....	9
3.1.4 Finisher Farms .....	9
3.1.5 Wean-Finish Farms .....	9
3.1.6 Nutrient Balances .....	10
3.1.7 Feed Management .....	10
3.1.8 Phytase Utilization .....	10
3.1.9 Manure Management .....	11
3.2 Data Collection and Analysis .....	12
4.0 Historic Data Collection and Analysis .....	20
5.0 Data Gaps and Needs .....	25
Appendices .....	26
Appendix A: Swine Biosecurity Guidelines .....	26
Appendix B: Swine Manure Sampling Protocol and Methodology .....	26
Appendix C: Quality Control Protocol for Swine Characterization Study .....	27
Appendix D: Manure Sampling for Nutrient Management Planning Fact Sheet .....	27
Appendix E: Response to Comments .....	38

## List of Tables

Table 1. Summary of swine production phases and weights considered categorically for this report.....	14
Table 2. Summary of swine manure content for manure storage categories of this report.....	14
Table 3. Wean pig weights over a four-year period.....	15
Table 4. Weights for Nursery Swine Barns.....	16
Table 5. Weights for Finisher Swine Barns.....	16
Table 6. Nursery manure nutrient content.....	17
Table 7. Finisher manure nutrient content.....	18
Table 8. Sow Farm manure nutrient content for farms with outdoor storage basins and deep pit under-floor storage in Pennsylvania.....	18
Table 9. Wean to Finish and Finisher Farm lagoon storage manure nutrient content in Virginia.....	19
Table 10. Historic non-lagoon swine manure analysis data from Virginia.....	21
Table 11. Historic lagoon swine manure analysis data from Virginia.....	22
Table 12. Historic sow farm nutrient values from Pennsylvania (all data post-phytase).....	23
Table 13. Historic nursery/grow-finish/finisher farm nutrient values from Pennsylvania.....	24

## List of Figures

Figure 1. Plot of non-lagoon manure analysis Total Nitrogen and Phosphorus values for Virginia.....	21
Figure 2. Plot of lagoon manure analysis Total Nitrogen and Phosphorus values for Virginia.....	22
Figure 3. Plot of sow farm manure analysis Total Nitrogen and Phosphorus values for Pennsylvania (all data post-phytase).....	23
Figure 4. Plot of nursery/grow-finish/finisher farm manure analysis Total Nitrogen and Phosphorus values for Pennsylvania.....	24

## **Abbreviations and Acronyms**

ASL	Agricultural Service Laboratory
CBP	Chesapeake Bay Program
Gal	Gallon
NASS	National Agriculture Statistics Service
N	Nitrogen
P	Phosphorus
USDA	United States Department of Agriculture
VADCR	Virginia Department of Conservation and Recreation
Yr	Year

# Swine Characterization Report

## 1.0 Introduction

The Chesapeake Bay (Bay) is the largest estuary in the Americas and recognized by the United States as a national treasure. About one quarter of land in the Bay watershed is used for some form of agricultural production. While agriculture is important in the provision of food and fiber and supporting local economies, it has been identified as the single largest source of nutrient and sediment pollution entering the Bay. In fact, according to 2012 estimates by the Chesapeake Bay Program (CBP), agriculture contributes 42% of the nitrogen (N) and 58% phosphorous (P) entering the Bay.

The Chesapeake Bay Program is a unique regional partnership that has led and directed the restoration of the Chesapeake Bay since 1983. The restoration efforts have primarily focused on reducing contribution of N, P, and sediment pollution to the Bay watershed from different sources. The CBP partners include members from different agencies in the states of Maryland, Pennsylvania and Virginia; the District of Columbia; the Chesapeake Bay Commission, a tristate legislative body; the Environmental Protection Agency (federal government representative); citizen advisory groups; local governments; non-profit organizations; and academic institutions. To determine the reductions of nutrients and sediment levels flowing into the Bay, stakeholders are using decision tool models to predict and track nutrients entering the Bay from the various land uses within Bay watershed. Model data inputs come from academic research, partner data collection efforts, and scientific based assumptions.

Important model input includes the annual mass and concentrations of manure nutrients generated within the Bay watershed. Currently, these inputs are estimated by multiplying a manure nutrient generation factor by the population of swine maintained or raised in the watershed over a one-year period. National agricultural experts develop the manure nutrient generation factor from reported research data. This approach presents an inherent challenge, notably, over- or under-estimation of manure nutrients if the factors are not representative of the livestock production systems found in the Bay.

Currently, annual watershed swine populations are based on the 5-year agricultural census data by the United States Department of Agriculture National Agriculture Statistics Service (USDA NASS). Typically, this census collects data at a county level, but not always with enough detail required to estimate the available mass of manure nutrients to be used as input to the Bay model. In years where USDA NASS does not collect census data, CBP's modeling tools estimate animal population using an algorithm developed by CBP modeling team and approved by the Program Partnership's Agriculture Workgroup. Briefly, the algorithm estimates watershed animal population at the county level from trends based on past USDA NASS censuses. Establishing annual trends over data collected every five years has called

into question the accuracy of the population estimates developed by the modeling algorithms. This uncertainty was validated in a report developed by the Agriculture Workgroup's Poultry Litter Subcommittee which compared the estimated Brooder/Poultry population numbers to annual Brooder/Poultry slaughter data collected by NASS. Consequently, the subcommittee concluded that new and more accurate sources of publically available production data are required to more accurately represent commercial Brooder/Poultry production in the CBP partnership's decision support tools for all areas of the Bay watershed. Subsequently, the Poultry Litter Subcommittee made a recommendation to build a regional database that accurately characterizes Brooder/Poultry and livestock populations in the Chesapeake Bay watershed on an annual basis at the county or sub-basin scale.

## **2.0 Goal and Scope**

The quantification of swine industry characteristics is important for Chesapeake Bay Modeling advancement. The purpose of this report is to provide current and historical perspective on the swine industry in regards to manure nutrient generation.

This report focuses on the mass generation rate and nutrient content of manure from commercial swine production systems in Pennsylvania and Virginia. The long term goal is to develop and maintain a database of swine manure production and nutrient concentration information that can be develop and improve equations relating manure generation rates to swine production groups. Using equations derived from locally derived data would increase the accuracy and quality of annual mass of nutrients (nitrogen and phosphorus) estimates used as inputs in the Bay watershed modeling tools. As a first step to achieve the goal, the kind of data to be collected was identified and collected from the Pennsylvania and Virginia region of the Bay watershed. The data was collected, processed, and analyzed, with results presented in this report. It is anticipated that collection of data will continue into future years and expanded to all regions of the Bay watershed.

## **3.0 Materials and Methods**

### **3.1 Description of Swine Production Systems**

Commercial swine production is primarily a partnership between swine companies (integrators) and private farmers. Although independently owned and operated swine farms still exist, the swine industry in the Chesapeake Bay Watershed falls largely into the following categorical units common to modern integrated swine production systems. The company owns the animals while the farmers raise the animals and manage the manure that results from production. Once the non-gestational animals reach maturity, they are collected by the swine companies and processed at designated regional plants. After the mature animals are removed, the production facilities on farms are cleaned and preparations are made to receive a

new herd. Depending on consumer markets, the number of herds a farmer raises may vary each year. Two products will result from a commercial swine farm, animals for meat and swine manure.

Swine production farms can be broadly classified into sow, boar, nursery, finisher, and wean to finish. A brief description of the general management of swine facilities in these production systems are described below.

### **3.1.1 Sow Farms**

A unit that maintains a sow herd for the purpose of producing pigs. Depending on the stage of the reproductive cycle, sows are housed in barns specific for breeding and gestation or farrowing (birthing), all at a common farm location.

Once bred, sows will be fed for a gestation period of 114 days. Shortly before her due date the sow is moved from the gestation barn to a room within the farrowing barn. The rooms are filled in a grouped system so that a newly filled room contains sows that are all due to farrow within the same 1-7 day period. This allows nursing sows in that group to all be weaned at the same time. The weaned piglets (approximately 12 to 15 pounds body weight each) are moved to an off-site nursery farm, while the sows are moved as a group back to the breeding/gestation barn where they are bred again. Wean age is typically about 21 days and sows will breed again about 5 days after weaning. Multiple farrowing rooms exist in modern facilities so that a new room can be used each week. After weaning and removal of the sows and the litter the room is washed and disinfected so another group of sows can move into the room. Thus the gestation and farrowing barns each operate with an internal rotation. Although there is variation due to age, body condition, genetics, etc., sows typically weigh 450 to 500 pounds each. Since younger and lighter females are included in these manure production estimates an average weight of 450 pounds should be used in modeling activities involving sow farms.

Young females that have not yet produced a litter are called gilts. A supply of gilts is necessary for sow farms in order to replace mortalities or culls (animal removed from the herd) from the herd for poor reproductive performance. Prior to introduction to the sow farm, gilts may be located at separate units called gilt development units (aka Isolation Barns). Sow farms will contain only a limited number of boars due to widespread adoption of artificial insemination, which imports semen from off-site boar studs. The boars on sow farms are utilized as 'teaser' animals in order to detect 'standing heat' in sows at which time the sow is artificially inseminated by a farm technician. The ratio of sows to gilts is approximately 10:1. The ratio of sows to teaser boars is 100:1 or greater.

For modeling activities, gilts and boars housed within a sow unit should simply be included as a member of the sow herd. Gilt development units that have separate manure storage, gilts may be considered finisher hogs (defined later in this report) since body size and feed rations are similar. Justification for this inclusion of gilts



into the finisher category is based on the fact that there are not a large number of gilt development units, or animal numbers, housed in this manner. Future modeling considerations may be given to a separate gilt isolation barn or gilt development unit category.

### **3.1.2 Boar Studs**

There are few farms in the watershed that house only boars. These facilities exist to supply semen to sow farms. Because ejaculates from boars typically contain many more sperm cells than are needed to impregnate a single sow, semen is diluted to create multiple artificial insemination doses. Thus, semen from a small number of boars will service all sows on a number of sow farms.

### **3.1.3 Nursery Farms**

Weaned pigs are typically moved from the sow farm to an off-site facility called a nursery farm. Some older farms maintain on-site nursery facilities at the sow farms, but the industry is largely moving away from this practice for herd health reasons. Nursery buildings allow specialized and focused management for young pigs. Buildings designed specifically for lower weight animals allow for efficient growth and economics. These facilities house young swine for approximately seven weeks, so at the age of ten weeks the animals are called feeder pigs and are moved to a finisher farm, weighing 50 to 60 pounds each.

### **3.1.4 Finisher Farms**

Feeder pigs are brought to the finisher farm where they will grow until they are 'finished', meaning they are grown to market weights of approximately 270 pounds. Once they reach this weight they are called market hogs and moved to the processing plant.

Both nursery and finisher farms operate in an all-in-all-out manner. This means that an entire building is populated at the same time and that all animals are removed at the same time. After the building is emptied, washing and disinfection occur prior to repopulation. Both types of barns are often constructed in very similar manners from site to site. Companies with multiple site management and efficient production have driven these common housing standards.

### **3.1.5 Wean-Finish Farms**

Wean-finish farms combine both the Nursery and Finishing phases of production into one barn. Pigs weighing 12 to 15 pounds are moved in after weaning and transportation from sow farms and are moved out at market weights of approximately 270 pounds. Thus, the pig remains at the same farm from weaning to market. Corporate farms owned and operated by Smithfield Hog Production Division in Virginia are wean-finish. Contract growers in Virginia and Pennsylvania more commonly house growing hogs in separate nursery and finishing facilities. While the number of farms and animals in this category is smaller than those in systems that provide separate nursery and finishing buildings, it is important to

maintain this category. The exact distribution of barn types across the watershed and among integrators is not known.

### **3.1.6 Nutrient Balances**

Sow farms contain enough sows that produce large enough litters to supply pigs to a number of nursery and finisher farms. For this reason there are far fewer sow farms compared to other units of production. However, sow farms may be higher in Animal Units and, depending on the farm's land base, may need to export manure nutrients. Swine manure is mostly liquid and very low in solid content. Therefore, exported swine manure is usually delivered to nearby neighbors and lands. It is not economically feasible to export swine nutrients more than a few miles or out of the watershed.

### **3.1.7 Feed Management**

Feed management at swine farms greatly impacts nutrient generation. It is in the best interest of these farms to utilize feed ration formulations that closely match the nutrient requirements of the animals. Swine within various stages of production (e.g., nursery or finisher) receive rations specifically balanced to meet their nutritional requirements as they grow in a system called "phase feeding". For example, finisher hogs may receive feed containing 18% crude protein from 45 to 90 pounds body weight, 16% crude protein from 90 to 135 pounds body weight, 15% crude protein from 135 to 180 pounds body weight, 14% from 180 to 225 pounds body weight, and 13% crude protein from 225 to 270 pounds body weight. Additionally, nutrient requirements of gilts and barrows (castrated males) differ so many farms will feed the animals in separate pens or barns, allowing consumption of different diets in a system called "split-sex feeding". Split-sex feeding is not universally conducted in the watershed, it is routine for some swine integrators and uncommon for others. By formulating diets that closely match amino acid (building blocks of protein) requirements nitrogen excretion is minimized.

### **3.1.8 Phytase Utilization**

Phosphorus excretion is also minimized by feeding diets that closely match the animal's phosphorous requirements and also through the utilization of phytase. Phytase is a commercially available enzyme that allows monogastric animals, like the pig, to efficiently digest phosphorus-containing molecules found in most grains. Adoption by swine integrators and widespread utilization of phytase technology has greatly decreased the need for inorganic phosphorus addition to swine diets, and has decreased by more than 20% the amount of phosphorus excreted into the environment each year.

Phytase is universally utilized in commercial swine bulk feed rations across the watershed. Adoption of phytase utilization as a Best Management Practice began in the late 1990s. Personal communications with feed mill management and agency personnel that assisted with securing grants to fund adoption technology indicate that in both Pennsylvania and Virginia, phytase utilization began in 1998. By 2000-

2001 phytase was used in 100% of swine diets fabricated by Wenger Feeds (Rheems, PA), including both sow and growing pig rations. In Virginia, Carroll's Foods (now Smithfield Hog Production Division) initiated swine phytase utilization in 1998. As communicated by Dr. Allen Harper, former Swine Specialist with Virginia Cooperative Extension, pigs fed with phytase supplemented diets excreted 21% less phosphorus resulting in an estimated annual phosphorus excretion reduction of 158,000 pounds in Virginia. Similar phytase utilization occurred by most watershed feed mills by 2002.

### **3.1.9 Manure Management**

Industry standards not only exist for housing design, but are common for manure storage as well. In the Northern watershed area, most modern nursery and finisher farms have deep pit manure storage that is under the floor of the swine barn. This system means that the barns can be constructed with minimal land footprint requirements. Sow farms may also have under-floor deep pit storage. Manure from deep pits is removed directly from the barns and applied to land.

Some sow farms and some older finisher sites have external open-air manure storage. These storage facilities are designed in a variety of manners, with most modern outdoor construction in the form of lined earthen basins or concrete structures. In northern areas of the watershed these facilities are simply outdoor manure storage basins. In southern watershed regions many outdoor manure facilities operate as true lagoons. In these systems, pens within barns are typically over shallow manure pits and are routinely emptied into large outdoor lagoons for storage. Many of these systems contain both a primary stage and secondary stage manure lagoon. When pits in barns are emptied, manure flows into the primary lagoon. There, solids within the manure settle to the bottom. As the level of liquid rises in the first stage lagoon, it flows through a pipe to the second stage lagoon. The contents of the second stage lagoon can be recycled back to the barn for shallow-pit flushing or to re-charge "pull-plug" pits. Pull-plug systems are shallow-pit that hold manure until a drain is pulled to release manure to primary manure storage containment. A third use for second stage lagoon liquids is spray-irrigation on adjacent farmland. Liquid from the second stage storage is expected to be very low in nutrient and solid contents since settled solids in the first stage will hold high concentrations of nutrients, especially phosphorus, in that storage area. While second stage liquid is irrigated to farmland on a routine basis, first stage solids can be retained in storage for years before removal is necessary. Lagoon systems can be considered a form of manure treatment since nutrients are removed and held for long periods. Other types of alternative manure treatments are not common with swine manure.

The following manure storage types are considered for this report:

1. Deep pit, under-floor manure storage
2. Outdoor storage basins (earthen or concrete)
3. Lagoons, including first and second stage treatments

### 3.2 Data Collection and Analysis

Several sources were utilized to assure that current data were available for this report. Country View Family Farms, in Pennsylvania, and Smithfield Hog Production Division, in Virginia, cooperated to provide manure analyses from many of their farms. Manure analyses that were older than 14 months were not considered. Technicians were also employed through contract to visit a number of farms to collect manure samples. Samples were sent to laboratories at either Clemson University or Penn State University for analyses. Both Country View Family Farms and Smithfield Hog Production Division also provided animal weights and farm inventories that were paired with manure analyses data. A third source was historic data provided from the VADCR database and several reputable sources. Producer information was removed from data for confidentiality.

Both historical and current data was used for this report. Swine manure nutrient concentration data was obtained from identified swine operations in Pennsylvania and from the VADCR nutrient database. The VADCR database stores samples collected from livestock and Brooder/Poultry operations in Virginia and sent to Clemson Agricultural Service Laboratory (ASL) for analysis. The data was used to see litter nutrient content changes over time. To discern nutrient concentrations for different production and animal types, only a subset of the data for the period 2012 to 2016 was used. This was because of the need to realistically, match and verify production and animal types associated with the manure analysis in the database. The team felt that going back to 2012 was reasonable. A combination of farmer and integrator surveys was conducted to identify animal and production type for the 2012 to 2016 data. Additional Pennsylvania split manure samples were collected during the summer of 2016 and sent to both the PSU Lab and Clemson ASL for analysis to augment the collected corporate and private grower data. Manure generation rate was determined using the 2016 data only, because of the challenges in getting reliable information for other years. The data collected included animal and production type, number of animals placed, number of animals transported, range and average animal production weights, mass of manure stored and removed from storages at total clean out, number of herds per cleanout, and number of herds raised per year.

The committee made several determinations based on industry standards and professional judgment that helped to shape the recommendations found in this report.

- Gilts and boars were included in sow farm data. Gilts are often housed with sows and the number of boars on sow farms is limited to those needed for heat detection. Future addition of these animal groups to the model, by inclusion of gilt development units and boar studs should be considered.
- Sows with litters are counted as sows. Even though nursing litters are with sows within the farrowing barns of sow farms, the piglets receive little or no

supplemental feed nutrients and the manure production of the litter is a very small fraction of that produced by the sow.

- Data received for sow farms in Pennsylvania (non-lagoon) did not usually distinguish whether the sample came from a farm with an outdoor storage basin or from a deep-pit under floor system. Because this information was unknown all samples were considered in the same category. It is reasonable to expect differences in analyses between these systems due to differences in exposure to precipitation. Further exploration of differences between these two types of systems is recommended for future refinements to the Model.
- Wean-Finish farms are not considered in this report. This type of production barn is less common than the multiple site nursery and finisher systems. There simply was not enough data available to create a separate category for this type of farm. The recommendation for this type of facility is to adjust animal weight accordingly to entry and exit weights, and to utilize actual farm manure samples. If manure samples are not available then finishing farm nutrient values should be used. The corresponding finishing animals represent far greater weights, feed consumption and residence time at these facilities. Future addition of this type of farm to the model should be considered.
- Weights reported represent the average weight of animals during the time they populate the specific phase of production. Adding entry and exit animal weights, and dividing that sum by two was used to determine average weights.
- Lagoon systems found in Virginia often contain both a Primary and Secondary manure lagoon. Manure nutrient data for lagoon systems is provided for both of these lagoons as well as a total average.
- Because this report was developed under time and resource constraints the data set from which conclusions are drawn is not perfect. Much data originates from only a few cooperative integrated companies. While the data from the farms within these large integrated systems is quite representative of the large number of animals managed within the company's systems, differences may be expected with other integrated systems due to variation in such factors as genetics, or feed regimens. Nonetheless, the judgment of this professional panel is that the variation noted here would not be great. We feel that this data set is a fair representation of the industry given the collection constraints noted above. Future endeavors should include larger data sets from a more diverse set of operations.

## Data

The following tables reflect averages determined from data provided through sources noted in the introduction of this report.

**Table 1. Summary of swine production phases and weights considered categorically for this report.**

Phase of Production	Average Animal Weight (lbs)	Typical Weight Range (lbs)
Sows (includes gilts and boars)	450	400-500
Nursery	34.99	13.30 - 56.68
Finisher	163.85	56.68 - 272.74

**Table 2. Summary of swine manure content for manure storage categories of this report.**

Manure Storage Type	TKN (lbs/1000 gal)	P2O5 (lbs/1000 gal)	K2O (lbs/1000 gal)
Sow with Outdoor or Under-floor Storage (non-lagoon)	29.80	12.13	17.82
Nursery	14.34	18.72	8.85
Finisher	26.22	20.65	27.93
Growing Pig Lagoon Primary Storage (2.4% solids)	2.72	7.52	5.72
Growing Pig Lagoon Secondary Storage (0.19% solids)	0.43	1.71	0.57

**Table 3. Wean pig weights over a four-year period.**

	Number of Farms in Data Set (n)	Total Wean Pigs Considered for Data	Range		Average Piglet Wean Weight (lbs) Exit Sow Farm
			Minimum Individual Farm Weighted Average Weight (lbs)	Maximum Individual Farm Weighted Average Weight (lbs)	
<b>2015</b>	11	920,691	12.78	14.12	13.52
<b>2014</b>	11	848,566	12.28	13.98	13.31
<b>2013</b>	11	709,057	13.03	13.79	13.25
<b>2012</b>	11	679,901	12.51	13.82	13.12
<b>Four year Average</b>		789,554			13.30

**Table 4. Weights for Nursery Swine Barns.**

	Number of Farms in Data Set (n)	Total Wean Pigs Considered for Data	Average Wean Pig Weight (lbs) Entry to Nursery	Total Feeder Pigs Considered for Data	Range		Average Feeder Pig Weight (lbs) Exit Nursery	During this Phase Average Feeder Pig Weight (lbs)
					Minimum Individual Farm Weighted Average Weight (lbs)	Maximum Individual Farm Weighted Average Weight (lbs)		
<b>2015</b>	13	920,691	13.52	474,406	51.89	59.92	57.28	35.40
<b>2014</b>	12	848,566	13.31	390,945	45.97	61.57	54.90	34.10
<b>2013</b>	10	709,057	13.25	366,786	52.64	60.74	55.49	34.38
<b>2012</b>	10	679,901	13.12	309,908	54.89	63.56	59.05	36.09
<b>Four year Average</b>		789,554	13.30	385,511			56.68	34.99

**Table 5. Weights for Finisher Swine Barns.**

	Number of Farms in Data Set (n)	Total Feeder Pigs Considered for Data	Range		Weighted Average Feeder Pig Weight (lbs) Entry to Finisher	Total Finisher Pigs Considered for Data	Range		Weighted Average Finish Pig Weight (lbs) Exit Finisher	During this Phase Average Finish Pig Weight (lbs)
			Minimum Individual Farm Weighted Average Weight (lbs)	Maximum Individual Farm Weighted Average Weight (lbs)			Minimum Individual Farm Weighted Average Weight (lbs)	Maximum Individual Farm Weighted Average Weight (lbs)		
<b>2015</b>	36	212,639	47.14	61.59	55.70	212,639	255.46	295.19	274.66	165.18
<b>2014</b>	31	169,042	41.82	58.74	53.35	169,042	248.99	294.89	270.20	161.92
<b>2013</b>	32	197,513	49.09	61.50	55.79	197,413	263.99	296.01	275.91	165.85
<b>2012</b>	30	190,929	49.17	63.53	54.58	190,929	255.69	285.77	270.17	162.46
<b>Four year Average</b>		192,531			54.86	192,506			272.74	163.85



**Table 6. Nursery<sup>1</sup> manure nutrient content.**

	Number of Farms in Data Set	Average Nutrient per Gallon (lbs/1000 gal)				Average Nutrient per Pound of Animal per year (lbs/lb animal/yr) <sup>2</sup>			
		NH4	TKN	P2O5	K2O	NH4	TKN	P2O5	K2O
<b>PA only Averages</b>	16 for NH4; 17 for other nutrients	16.34	20.74	10.19	19.58	0.0622	0.0798	0.0358	0.0755
<b>VA only Averages</b>	17 for all nutrients	3.67	7.20	1.19	7.90	0.0292	0.0586	0.0097	0.0642
<b>Combined Average (both states)</b>	19 for NH4; 20 for other nutrients	14.34	18.72	8.85	17.83	0.0564	0.0763	0.0315	0.0736

<sup>1</sup>Nursery pigs begin this phase of production when wean pigs weighing 12 to 15 pounds enter the barn and exit after about seven weeks as Feeder pigs weighing 50-60 pounds and enter a finisher barn.

<sup>2</sup>A weight of 34.99 pounds is used for calculations and represents the average weight of pigs during this stage of production (entry and exit animal weights added and sum then divided by two) as determined from data available for this report.

**Table 7. Finisher<sup>1</sup> manure nutrient content.**

	Number of Farms in Data Nutrient Set	Average Nutrient per Gallon (lbs/1000 gal)				Number of Farms Providing Inventory Data	Average Nutrient per Pound of Animal per year (lbs/lb animal/yr) <sup>2</sup>			
		NH4	TKN	P2O5	K2O		NH4	TKN	P2O5	K2O
<b>PA only Averages</b>	29	26.65	35.95	29.55	35.98	29	0.0236	0.0316	0.0285	0.0316
<b>VA only Averages</b>	14	3.94	6.07	2.21	11.27	10	0.0041	0.0062	0.0017	0.0132
<b>Combined Average (both states)</b>	43	19.26	26.22	20.65	27.93	39	0.0186	0.0251	0.0216	0.0269

<sup>1</sup>Finisher pigs begin the finisher phase of production weighing approximately 50 to 60 pounds and are marketed at weights of approximately 270 pounds. Average finisher pig weight is approximately 165 pounds.

<sup>2</sup>A weight of 163.85 pounds is used for calculations and represents the average weight of pigs during this stage of production (entry and exit animal weights added and sum then divided by two) as determined from data available for this report.

**Table 8. Sow Farm<sup>1</sup> manure nutrient content for farms with outdoor storage basins and deep pit under-floor storage in Pennsylvania.**

	Number of Farms in Data Nutrient Set	Average Nutrient per Gallon (lbs/1000 gal)				Average Nutrient per Pound of Animal per year (lbs/lb animal/yr) <sup>1</sup>			
		NH4	TKN	P2O5	K2O	NH4	TKN	P2O5	K2O
<b>PA only Average<sup>2</sup></b>	11	20.62	29.80	12.13	17.82	0.0751	0.1096	0.0475	0.0613

<sup>1</sup>Sow Farms include sows and a relatively smaller number of boars and gilts. The average animal weight on sow farms is routinely considered to be 450 pounds.

<sup>2</sup>No nutrient data was received from VA for this non-lagoon type of outdoor storage.

**Table 9. Wean to Finish and Finisher Farm<sup>1</sup> lagoon storage manure nutrient content in Virginia.**

	Number of Samples in Data Set <sup>2</sup>	Average Nutrient Content (lbs/1000 gallons)								% Solids
		NH4	N	TKN	P205	K2O	Ca	Mg	Na	
<b>Primary Only</b>	51	4.80	2.72	7.52	5.72	10.14	2.48	1.47	2.06	2.40
<b>Secondary Only</b>	23	1.28	0.43	1.71	0.57	5.88	0.42	0.17	1.22	0.19
<b>Combined Primary and Secondary</b>	74 <sup>2</sup>	3.70	2.01	5.72	4.12	8.82	1.84	1.07	1.80	1.71

<sup>1</sup>Wean to finish farms grow pigs from 12 to 15 pounds to a weight of approximately 270 pounds. Finish farms grow pigs from 50 to 60 pounds to approximately 270 pounds.

<sup>2</sup>Some data originated from the same farms that contain both primary and secondary storage lagoons. Thus these farms contributed multiple manure samples.

#### **4.0 Historic Data Collection and Analysis**

Historic data of swine analysis was gathered from two sources. First, a report generated by the Virginia Department of Conservation and Recreation, Soil and Water Conservation Division's Nutrient Management Program's Animal Waste Coordinator (Bobby Long) included manure analysis summaries for storage facilities listed as either 'Mixed' or 'Lagoon'. The number of samples or source was not included with this data. Designation of production phase was not indicated with this data.

The second historic manure analysis data source was the Penn State Agricultural Analytical Service Laboratory. The data set was purged of data that did not fit criteria of this report and some data from known research projects was removed. However, the remaining data possibly contained samples analyzed from non-commercial swine sources as part of other research endeavors. Data was separated into either 'Sow' or 'Non-sow' categories. Sow categories include some farms listed in the data set as 'Farrow-to-Feeder', meaning that Nursery phases of production may be included within the sample. A second summary is presented for categories that included 'Nursery', 'Grow-Finish', 'Finisher' and 'Other'. Two manure samples from Maryland were included in this data. All farms listed with a Pennsylvania location were kept. Some of these farms are surely not located within the Chesapeake Bay watershed, however swine industry demographics would indicate that the majority of samples come from within the watershed.

Data from both sources are summarized below.

**Table 10. Historic non-lagoon swine manure analysis data from Virginia.**

Historic Non-lagoon Swine Manure Nutrient Values (Virginia)						
Year	Number of Samples in the Year	TKN (lbs/1000 gal)	NH-4 (lbs/1000 gal)	P205 (lbs/1000 gal)	K20 (lbs/1000 gal)	% Solids
1990	unknown	88.20	88.20	58.42	69.76	3.30
1991						
1992	16	133.90	94.24	82.86	54.63	2.34
1993	24	171.89	113.76	116.84	73.85	5.21
1994	9	164.84	118.64	147.33	75.56	5.35
2001	1	154.39	117.96	193.21	106.62	6.93
2002	14	113.40	75.78	34.07	58.97	2.69
2003	13	71.98	46.06	19.70	45.86	2.00
2004	10	104.36	63.59	33.52	55.28	2.51
2005	7	134.42	94.57	25.93	78.73	2.88
2006	11	110.99	71.57	35.12	59.36	3.69
2007	5	107.41	71.19	32.33	69.01	2.98
2008	6	108.94	77.37	24.60	60.30	2.85
2009	13	101.31	74.94	34.10	64.53	7.91
2010	8	93.33	68.35	17.17	42.99	1.80
2011	6	109.98	76.67	22.48	57.32	2.94
2012	3	81.18	60.37	14.26	54.96	1.14
2013	3	56.38	136.00	56.52	0.00	5.22
2014	2	118.65	67.31	37.12	52.56	3.11
2015	2	63.14	48.23	8.47	46.00	0.79

**Figure 1. Plot of non-lagoon manure analysis Total Nitrogen and Phosphorus values for Virginia.**

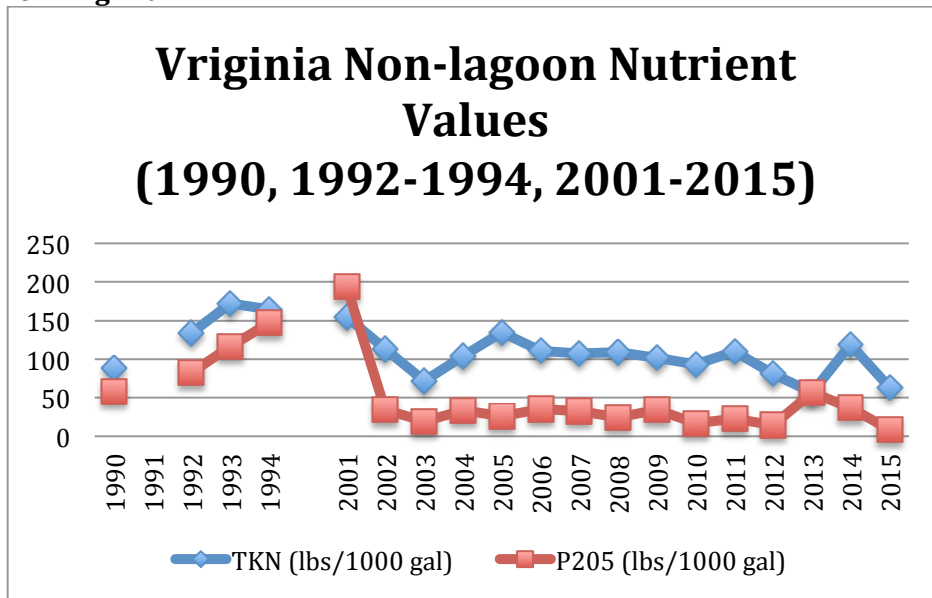

**Table 11. Historic lagoon swine manure analysis data from Virginia.**

Historic Lagoon Swine Manure Nutrient Values (Virginia)						
Year	Number of Samples in the Year	TKN (lbs/1000 gal)	NH-4 (lbs/1000 gal)	P205 (lbs/1000 gal)	K20 (lbs/1000 gal)	% Solids
1990	unknown	56.92	32.98	130.77	13.18	0.72
1991	53	81.65	48.58	52.79	37.32	2.76
1992	57	86.74	49.50	57.71	40.95	2.88
1993	37	23.19	11.84	12.84	15.26	0.34
1994	12	20.02	12.80	7.71	18.60	0.04
2001	12	24.63	19.78	5.13	59.50	0.70
2002	67	34.57	25.19	6.75	47.31	0.93
2003	83	28.11	22.56	4.94	40.06	0.55
2004	90	29.04	23.85	4.35	39.89	0.50
2005	87	30.19	23.95	4.90	42.20	0.77
2006	94	31.61	23.56	7.52	41.81	0.75
2007	69	29.15	20.73	4.80	39.55	0.56
2008	53	24.63	18.39	3.40	39.69	0.55
2009	69	28.80	20.47	7.01	45.69	1.01
2010	66	25.33	17.69	6.24	35.04	0.79
2011	65	32.96	20.82	9.75	41.18	1.22
2012	40	23.25	18.73	2.43	44.06	0.49
2013	33	33.65	23.25	10.10	45.31	0.99
2014	33	32.27	17.69	4.30	37.12	0.87
2015	38	29.84	20.82	3.02	42.26	0.54

**Figure 2. Plot of lagoon manure analysis Total Nitrogen and Phosphorus values for Virginia.**

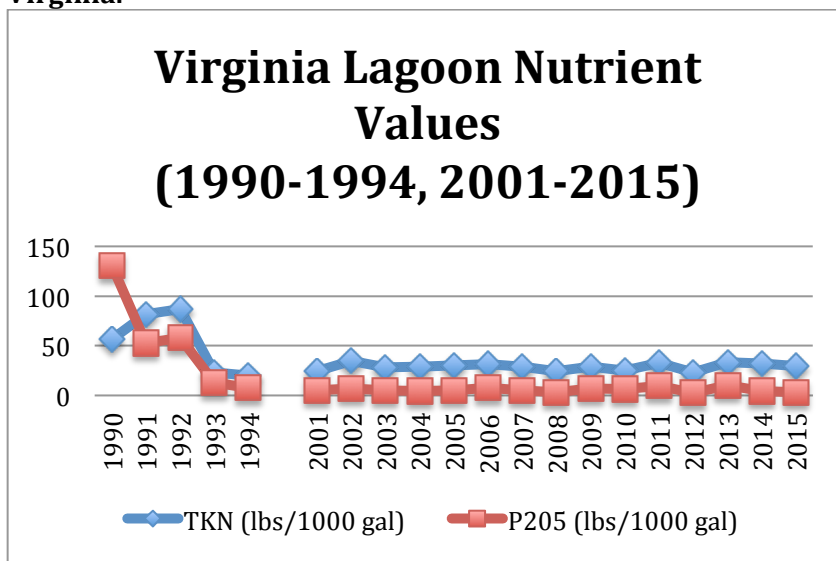

**Table 12. Historic sow farm nutrient values from Pennsylvania (all data post-phytase).**

Historic Sow Farm Data (Penn State AASL)						
	Number of Samples in the Year	TKN (lb/1000 gal)	NH4 (lb/1000 gal)	P2O5 (lb/1000 gal)	K2O (lb/1000 gal)	% solids
2003	13	23.31	19.54	7.15	13.57	2.46
2004	2	12.78	10.01	2.44	7.94	1.02
2005	3	14.67	14.52	1.19	9.20	0.63
2006	3	8.76	7.40	1.92	7.78	0.74
2007	7	15.74	10.15	9.16	8.82	2.04
2008	0					
2009	1	11.57	8.36	0.74	6.73	0.45
2010	25	26.95	15.86	8.61	12.25	2.55
2011	25	21.57	15.30	4.74	9.29	2.24
2012	52	24.31	17.51	4.49	12.66	1.59
2013	14	30.71	19.84	5.17	17.03	2.16
2014	24	30.34	17.68	8.30	16.79	2.13
2015	11	26.61	16.39	5.46	14.07	1.88
2016	16	26.02	16.25	4.66	16.23	1.95

**Figure 3. Plot of sow farm manure analysis Total Nitrogen and Phosphorus values for Pennsylvania (all data post-phytase).**

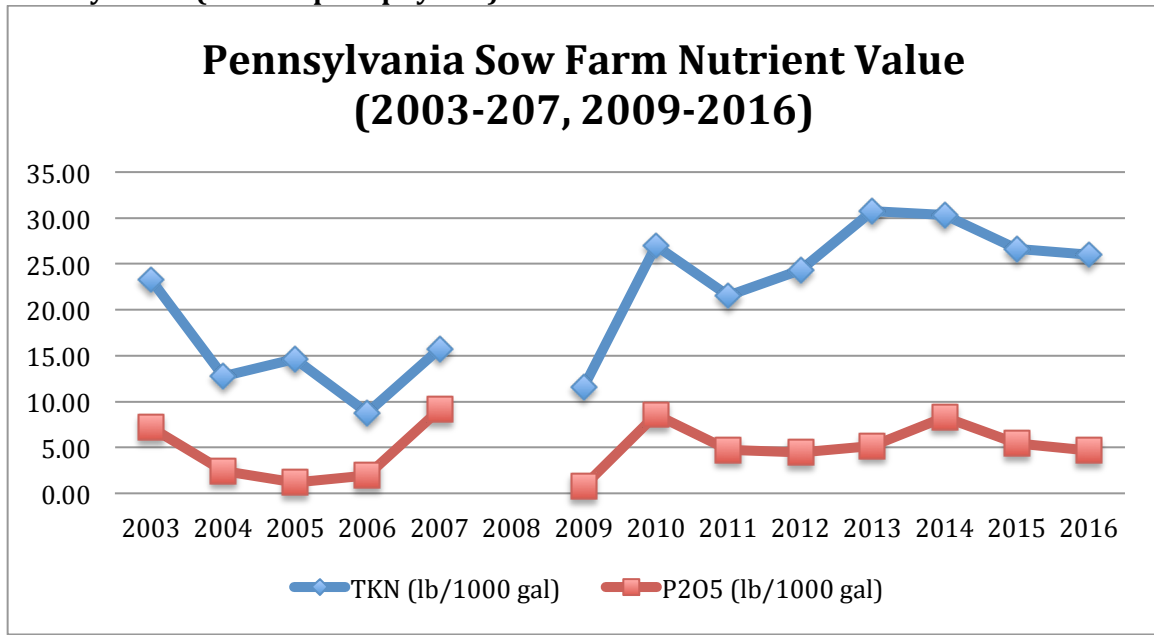

**Table 13. Historic nursery/grow-finish/finisher farm nutrient values from Pennsylvania.**

Historic Nursery/Grow-Finish/Finisher Farm Data (Penn State AASL)						
	Number of Samples in the Year	TKN (lb/1000 gal)	NH4 (lb/1000 gal)	P2O5 (lb/1000 gal)	K2O (lb/1000 gal)	% solids
1998	2	45.21	30.97	11.37	15.09	4.05
1999	79	36.80	24.48	14.88	15.66	4.39
2000	24	41.25	21.07	12.32	14.74	4.26
2001	26	43.57	26.84	10.65	18.80	4.41
2002	25	26.11	20.54	7.50	14.25	2.89
2003	71	18.46	15.93	4.22	11.81	1.87
2004	60	20.94	17.24	5.04	11.44	2.21
2005	42	38.33	29.53	12.11	19.09	4.97
2006	52	39.50	28.89	11.08	22.96	4.63
2007	12	30.97	23.01	7.24	19.82	2.69
2008	71	27.26	19.16	7.61	14.49	2.85
2009	21	30.70	20.50	6.62	17.89	2.99
2010	13	36.03	19.82	7.53	21.78	3.57
2011	40	28.08	18.05	6.62	12.73	3.17
2012	37	32.06	22.76	8.56	16.50	3.37
2013	26	34.98	19.98	12.16	18.46	3.97
2014	31	35.73	21.40	9.48	21.34	3.31
2015	16	36.64	22.78	8.90	24.13	3.81
2016	21	36.98	24.58	9.24	23.38	4.09

**Figure 4. Plot of nursery/grow-finish/finisher farm manure analysis Total Nitrogen and Phosphorus values for Pennsylvania.**

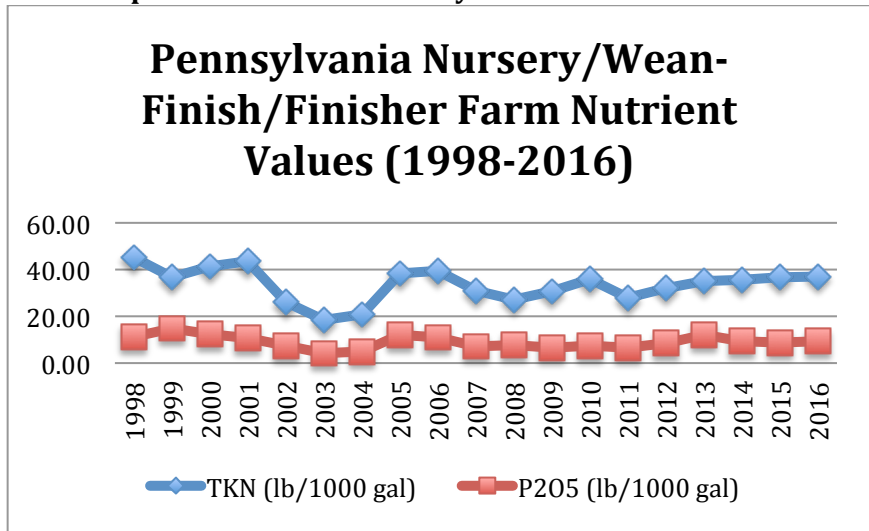



## **5.0 Data Gaps and Needs**

The team recommends that collection of data to characterize swine manure generation and nutrient contents be continued in Pennsylvania and Virginia and expanded to other integrator companies and regions of the Bay watershed. All production systems and animal types should be identified in each state and common terminology developed to describe them. An ongoing system to accept farm specific production data should be established. Summarized data should be collected in a manner that eliminates disclosure of confidential business information. This data can be used as the foundation for improving manure generation rate and nutrient concentration goals.

## APPENDICES

### **Appendix A: Swine Biosecurity Guidelines**

The following protocol was followed during data collection.

- Respect all entrance prohibitions on swine farms and /or barns
- Only enter a swine house if absolutely necessary. **NO Entrance on Infected Barn Under Any Conditions**
- Upon arrival at any swine farm, report to the farm manager or responsible party
- Wash hands immediately upon arrival before putting on disposable gloves, and again before leaving farm.
- Leave vehicles outside of service areas. Walk!
- Avoid visiting two swine farms within 48 hours if possible absolutely no visitation of swine farms from two separate sow units within 48 hours
- Wear Boots that can be disinfected, disposable gloves
- Put all manure samples into sealed bottles, spray outside of bottle and then put sample into sealable plastic bag.
- All materials used on the site must be disinfected before and after use
- Boots should be dipped at the entrance and exit of every farm with Clorox solution or Vircon solution
- Spray all equipment with a mix of 8 oz. of Clorox/gallon or 10% Vircon solution of water until wet. Leave on for 30 seconds. Dry off with disposable paper towels. Put gloves and paper towels in plastic bag and keep tightly sealed.
- Keep cleaned materials away from contaminated materials.
- Remove all dry litter, manure, mud, straw etc. from vehicle, especially wheels and wheel wells
- Spray wheels, tires and wheel wells with disinfection solution. Let drain and dry before moving. If dusty or wet, spray underside of vehicle. Alternative: park vehicle outside farm entrance and WALK!

### **Appendix B: Swine Manure Sampling Protocol and Methodology**

For the Swine characterization study in Pennsylvania, manure samples are taken from under-floor deep pit storage of each barn located on the farm visited. The samples from each barn are mixed together unless the grower indicated that the manure from each barn is treated differently on separate fields. The samples are mixed in a plastic bucket and transferred to 500 ml bottles, labeled, refrigerated until prepared for shipping to Clemson and PSU laboratories.

Samples are taken using a Teflon Liquid Point Cup Sampler with lid, controlled in the handle so that samples taken from the under house storage can be taken at varying depths, as mixing of the storage is not feasible. The sampler is inserted into the manure inverted until the desired depth is reached in the pit. It is then turned over and the lever in the handle is pushed so that manure can be gathered. Since the pits are six feet deep samples are taken at 1.5 ft., 3.0 ft. and 4.5 ft. The samples are poured into a bucket mixed and then the composite sample is delivered into 500 ml

labeled bottles, refrigerated until shipping. This procedure is consistent with PSU's Agronomy Fact Sheet #69 "Manure Sampling for Nutrient Management Planning".

All Equipment is then washed, and sprayed down with a 10% solution of Vircon dried and placed separately from any sampling material as spelled out in the Bio-Security Protocol.

### **Appendix C: Quality Control Protocol for Swine Characterization Study**

As a Co-principal investigator of the Swine Characterization Study, it is the responsibility of Tim Sexton to make sure that the IRB standards are met and followed, that the farmer interview procedures are maintained, the sampling procedures outlined are followed, and the bio-security procedures are strictly adhered to.

At the beginning of the project, I met with the intern, Jordan Kristoff and explained the protocols and the security issues both with personal data that would be collected, the routines that would be expected, the strict bio-security procedures that would be required on all farm visits, and the IRB process that would also be required.

The intern was awarded a VT computer so that no information collected would be stored on any DCR or government related server, or computer or storage device. All hand written data sheets and notes are kept in a secure location, with access only to the intern and the Co-PI.

The Co-PI checked the data base that was created on a weekly basis for journal entry errors, and entries that appeared to be outside the norm, and requested that the interns follow back up with those farmers to see if they could determine why the information gathered might be outside the norm. The data collected from Smithfield Hog Production Division is maintained on one data sheet, and the Country View Family Farms data base is maintained on another to insure that there is no cross contamination of data collected.

The intern is quizzed on a regular basis to make sure that she is continuing to follow the questioning process for all farmers, that the sampling procedures are the same, and that the bio-security procedures are being adhered to.

Information forwarded to the VT and/or PSU PI is also copied to this PI so that if a question arises, this PI has the ability to answer if possible.

### **Appendix D: Penn State Fact Sheet #69, Manure Sampling for Nutrient Management Planning (attached at the end of this report as a supplement)**

## Appendix E: Swine Characterization Project Draft Report Comments and Responses

Comment responses provided collectively from Timothy Sexton, Mark Estienne and Robert Meinen. Finalized December 16, 2016.

Note: page numbers referred to below may differ from sections in the final report due to page modifications between draft and final versions.

### Summary of Comments Received on the Recommendations to Estimate Swine Nutrient Generation in the Phase 6 Chesapeake Bay Program Watershed Model

#### General Comments

- None

#### Section: Materials and Methods

- **PA SCC & DEP:** Page 5 – Methodology. How many other integrators are in the watershed?
  - **Response:** At this time the total number of integrators in the watershed is unknown. With the exception of one farm site in Northern Virginia on contract with Country View Family Farms, Smithfield Foods, Inc. is the sole integrator in Virginia. In Pennsylvania there are several integrators. The panel's integrator knowledge in Delaware, Maryland, New York, and West Virginia is limited. In the watershed there are likely fewer than ten integrators, with Country View Family Farms and Smithfield representing the largest companies.
- **PA SCC & DEP:** Page 5 – Methodology. Why were manure analyses that were older than 14 months not considered?
  - **Response:** We were looking to make an assessment of manure samples that were current, the rationale being that concentrations may have changed over periods longer than 14 months.
- **PA SCC & DEP:** Page 5 – Methodology. Was the same sampling protocol found in Appendix 2 followed by those in Virginia as well as those in Pennsylvania? How many farms were samples taken by technicians versus samples that were taken by farmers? For future research, it would be interesting to split samples and send to each lab to see what the outcome would be, particularly after seeing the very large difference between the analyses in the operations in the two states.
  - **Response:** The identical manure sampling protocol for project obtained and analyzed manure samples was used by trained technicians in both Pennsylvania and Virginia. The technicians obtained 22 manure samples in Pennsylvania, which were split sampled and sent to both Clemson and PSU laboratories for analyses. The remaining manure sample analysis data obtained by the project were provided by the corporate or swine operators from documented laboratory reports and data. In Virginia, all manure samples taken in 2015-2016 for analyses were obtained using a consistent sampling protocol by trained field technicians, with the exception of corporate owned facilities, which were taken independently by corporate staff. The Clemson laboratory performed the analysis for all Virginia manure samples.

- **PA SCC & DEP:** Page 6 – Methodology. Is the wean-finish type more prevalent with other integrators?
  - **Response:** While recent industry structure favors separate nursery and finisher barns, there remain a number of wean-finish farms in the watershed. Some are older and have not been converted to a stand-alone nursery or finisher farm. There is not a set pattern for any particular integrator as farm owners can sign contracts with different hog suppliers without changing building conformation. Many corporate-owned Smithfield farms in Virginia are using wean-to-finish, but Smithfield Contract growers are not.
  
- **PA SCC & DEP:** Page 6 – Methodology. Is there a reason to provide an average of the Primary and Secondary lagoons?
  - **Response:** This is the primary type of operations found in Virginia. Some operations had samples from both the primary and secondary, some only had samples from one or the other but not both. In manure application situations it is important to know the analysis of the particular manure source.
  
- **PA SCC & DEP:** Page 6 – Methodology. This seems like a very small study group to estimate swine nutrient production for all six states, particularly because it only included two integrators in two states.
  - **Response:** Due to the time constraints of the study, the two integrators were used, as they were the only ones fully willing to participate in the timeframe given. The protocol provided by the Ag Work Group and the WQGIT prior to the beginning of the project stated that in order for the work group to consider the information a minimum of 30 samples should be represented by each type. This could have easily been accomplished with one integrator, however we thought it would be much better to represent the two largest integrators in the region.

#### Section: Description of Swine Production Systems

- **PA SCC & DEP:** Page 3 – Wean-Finish Farms. Is Smithfield Hog Production Division the only integrator that owns and operates wean-finish farms? Possibly a statement could be made that there are other integrators that own/operate wean-finish farms, but only one is provided in this study.
  - **Response:** As noted above the answer to this is unknown at this time. Only Smithfield had farms of this type in the current study. This study is not entirely inclusive of all integrators and operators in the watershed. Even though there are not a large number of farm of this type in the current data set the panel feels that inclusion of this data is important to act as a starting point and placeholder for future work. Clarification language has been inserted into the report.

- **PA SCC & DEP:** Page 4 – Suggest striking the first paragraph, which states, “Nursery and finisher units are often within a balance between nutrient generation and on-site farm crop nutrient needs...” In Pennsylvania, many finisher operations need to export the manure produced on their operation due to not having enough land base for application as well as increasing soil phosphorus levels.
  - **Response:** The panel agrees that this paragraph was poorly written. It has been removed from the final text.
  
- **PA SCC & DEP:** Page 4 – Feed Management. Is split-sex feeding an industry standard, or is this only done by one or two integrators? If the latter, we recommend striking from the report.
  - **Response:** Split sex feeding is a normal practice in Virginia. In Pennsylvania split-sex feeding is not a common practice. Wording in the final draft concerning split-sex feeding will clarify that the practice is not universally utilized.
  
- **PA SCC & DEP:** Page 4 – Phytase Utilization. Is Phytase used in any states other than Pennsylvania and Virginia?
  - **Response:** Phytase was consistently present in all rations for hogs in this study. It is believed that all commercial swine bulk feed in the watershed contains phytase.
  
- **PA SCC & DEP:** Page 4 – Phytase Utilization. “Similar phytase utilization occurred by most watershed feed mills by 2002.” What is the percentage of feed mills that did not utilize phytase by 2002?
  - **Response:** Unknown.
  
- **PA SCC & DEP:** Page 5 – “The contents of the second stage lagoon can be used to refill manure pits within the barn.” Does this mean that shallow pits will be flushed?
  - **Response:** Report text has been modified for clarification. Shallow pits are sometimes flushed with secondary lagoon liquids. However, it is more common for shallow pits to be “pull-plug” type, for which the plug to a pit is pulled to drain contents to the lagoon. After draining, the plug is replaced, and pit recharged with water from second stage lagoon. Both types of systems will exist in the watershed.

Section: Data Collection and Analysis

- **PA SCC & DEP:** Page 7 – Table 2. Why are the sow storages combined? Outdoor storages receive precipitation (dilution) and underfloor storages do not.
 

**Response:**

  - Most data received for sow farms in Pennsylvania (non-lagoon) did not distinguish whether the sample came from a farm with an outdoor storage basin or from a deep-pit under floor system. Because this information was unknown all samples were considered in the same category. Further exploration of differences between these two types of systems is now recommended in the report.

- **PA SCC & DEP:** Page 8 – Table 3, 4, and 5 Please provide footnotes, where necessary, to explain why values are reported out to the hundredths or more. There should be a standard footnote across the board for all reports.
  - **Response:** All weight data in these tables are expressed consistently to the hundredth decimal level. This is a common decimal expression in industry reporting.
  
- **PA SCC & DEP:** Page 10 – Table 6 and Table 7. Is there an explanation as to why the manure nutrient content levels are so different between the two states? This is where a split manure sample may have been beneficial to see how the testing protocols may be different between Clemson University and Penn State University.
  - **Response:** All operations in Virginia are on lagoon systems and subject to dilution, long term storage, settling and treatment. All of the Pa systems visited were under house storage with no dilution from rainfall. We would expect them to have different characteristics. Clemson and Penn State laboratories utilize standard protocols and lab management assured the team that analyses at either lab would provide similar results. Some samples were split and sent to each laboratory. No comparison was available when this report was drafted due to time constraints. This comparison may be recommended as for inclusion in future work.

Section: Appendices

- **PA SCC & DEP:** Page 18 – Appendix 2. The sampling protocol for Pennsylvania is listed, but not for Virginia. Did technicians in both states follow the same sampling protocol?
  - **Response:** The sampling protocol for both states is the same. One of the main goals of this characterization study was to standardize the sampling procedures for future reference.



Agronomy Facts 69

# Manure Sampling for Nutrient Management Planning

## INTRODUCTION

Manure is an excellent source of many essential plant nutrients and, with proper management, can meet nearly all crop nutrient needs. Sampling manure for analysis is an essential and valuable nutrient management tool for determining the nutrients available in manure. Manure test results, combined with soil test recommendations and manure spreader calibration, form the basis for determining appropriate manure application rates to meet crop nutrient needs.

It is important to know the nutrient content of the manure being applied in order to maximize the economic benefit of the nutrients in achieving yields and reducing fertilizer costs. Likewise, knowing the nutrient content of manure is helpful in reducing the environmental impacts from excess nutrient application.

The purpose of this fact sheet is to highlight the importance and value of manure sampling and analysis and to outline practical guidelines and procedures for taking manure samples.

## WHY TEST MANURE?

Unlike fertilizer, manure form and composition, and therefore nutrient analysis, can vary widely. Manure nutrient content is obtained in two common ways for planning purposes: (1) manure sampling and laboratory analysis of manure produced on the farm, or (2) “book values.” Book values are developed by averaging the results of a large number of tests for a common manure type (Figure 1).

Book values can be used as a starting point for estimating initial manure application rates when test results are not yet available. However, book values or averages seldom reflect the actual nutrient content of the manure from a specific farm. Variations in manure composition and nutrient content occur from farm to farm due to differences in diet and feeding programs, type and amount of bedding, the amount of rain or wash water added, manure handling, and manure storage. Proper sampling and analysis is the only way to obtain farm-specific manure nutrient content and avoid the adverse impacts of over- or underapplication of manure nutrients.

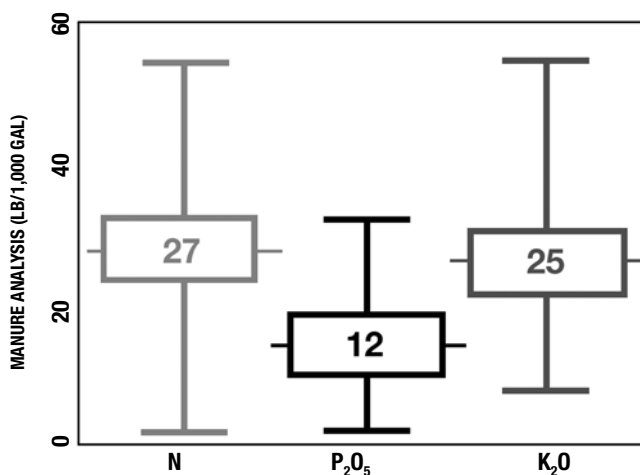

**Figure 1. Manure analysis average nutrient concentration and variations from 311 farmer-submitted dairy manure samples in Pennsylvania. Average values and the range of values for liquid dairy manure samples submitted to Penn State Agricultural Analytical Services over a period of time. The averages in the boxes are very close to most published book values for dairy manure, but the range in individual analyses is very wide. Summaries from many other labs have shown similar results.**

Source: Penn State Agricultural Analytical Service Laboratory.

## WHEN TO SAMPLE

Collecting a representative sample for analysis is the single most important factor affecting the accuracy of manure nutrient content. Obtaining a representative sample is also the most challenging aspect of the manure sampling process. Keep in mind that the sample must represent the actual manure being spread. If sampling is not done correctly, the results of the analysis can be worse than having no analysis at all.

Because only a small amount of manure is sent to the laboratory for analysis, it is imperative that the sample represent the average composition of the manure being applied. The two critical aspects of sampling are the timing of sampling with respect to the manure’s application and the ease or difficulty of the required sampling procedure. Both of these factors are related to variations in nutrient content that occur over time or are present in manure based on how the manure is stored and handled.



Even on a single farm, both weather and management can affect the nutrient composition of manure. Seasonal variations in temperature and precipitation can change nutrient content through dilution, evaporation, and volatilization, particularly in uncovered storages and stacks. Manure stored in barns as bedded pack or litter or stored in covered stacks is typically not affected by weather, but there is often significant variation in nutrient content throughout the manure based on the uneven mixing of bedding, hay, and/or spilled feed. Finally, a single liquid manure source can have a large variation in nutrient content if the manure is not thoroughly agitated and mixed before spreading.

When is the ideal time to collect a manure sample?

Because the goal is to collect a sample that represents the manure actually being applied, the best time to sample is during loading or field application. The sample can be obtained during loading of manure application equipment or in the field as the manure is being spread. Sampling at this time has several advantages:

- The time-related changes in nutrient content caused by management and weather are minimized.
- The nonuniformity due to lack of mixing is reduced. Subsamples can be taken as the manure is loaded, which results in more representative samples.
- The difficulty of collecting representative samples while manure is in the storage, barn, or stack is reduced.
- The complexity of the sampling equipment required is reduced.
- In some cases, the sampling procedure is safer, reducing the risk of falling in or being overcome by gases.

There is one disadvantage to sampling during spreading: the analysis results from samples collected at this time will not be available to calculate manure application rates for that application. However, the results can be used to calculate future application rates. It is recommended that the manure nutrient content values used in calculating manure application rates be based on running averages or baseline values. To obtain these values, each manure group should be sampled annually for three to five years. After the initial period, manure can be sampled periodically to monitor the nutrient values. See the “Manure Analysis Records and Creating a Baseline” section for practical guidelines on how to use multiple manure analysis results. If there are changes in feeding programs or manure storage and handling, the manure should be resampled. As long as no significant changes are made in the production system, the nutrient content of the manure should remain fairly constant.

Some states may have specific regulatory requirements related to manure sampling that may vary from the general guidance provided above and elsewhere in this fact sheet. When developing a manure sampling program, farmers, consultants, and nutrient management planners should learn and integrate their state regulatory requirements with the guidance outlined in this fact sheet.

## **GENERAL MANURE SAMPLING GUIDELINES**

After selecting the manure testing lab, check with the lab for specific guidelines or requirements regarding sample size, package and shipping requirements and guidelines, analytical options, costs, and turnaround times. Some labs provide containers, labels, and submission forms. See the “Selecting a Lab” section for some practical considerations for choosing a manure analysis laboratory.

Generally, most sampling methods create a composite sample from multiple subsamples that have been thoroughly mixed. The necessary equipment and supplies will vary depending on the type of manure being sampled and the method of sampling.

Manure samples should be taken with clean steel or plastic shovels, scoops, or cups and placed in a clean five-gallon plastic bucket to make a composite sample. Using tools and equipment made of nonreactive materials, such as stainless steel and plastic, and thoroughly cleaning them between samples will prevent contamination of samples. Do not use galvanized containers because they can influence analysis results.

Composite samples should be sent to the lab in plastic bottles (liquid and solids), or one-gallon heavy-duty ziplock plastic bags can be used for dry material like broiler litter. Do not use glass containers for either sampling or shipping because of the risk of breakage, leakage, and possible injury.

Depending on the sampling method, other equipment such as tarps, a piece of plywood, or a solid manure sampling probe may be required. Ice chests should be used in warm weather to keep samples cool during the sampling process.

Each sample should represent the manure that is being land applied. In many liquid manure storage systems there is considerable variation in the manure, even within a storage unit. If liquid manure is agitated sufficiently to achieve uniformity throughout the storage, one sample is adequate to determine the nutrient levels of that manure. Note, however, that it is very difficult to uniformly mix large liquid storages (more than 250,000 gallons). If there are obvious changes in the manure as the storage is being emptied, such as consistency or color, several separate samples should be collected to represent this variation.

Sampling procedures vary depending on whether the manure is a solid or a liquid. Also, for each manure type there are several possible ways to collect a representative sample. These recommended sampling procedures are discussed below.

## **SOLID MANURE SAMPLING PROCEDURES**

The following sampling procedures can be used for manure, poultry litter, and compost. It is recommended that solid manure be sampled while loading the spreader or during application in the field. Sampling directly from a bedded pack or stockpile is not recommended. Samples should be collected throughout the entire emptying or application process. Samples should be taken from loads representing the beginning, middle, and end of the process.

### Sampling During Loading

During the process of loading the spreader take a sample of the manure and place it in the bucket. A minimum of five samples of approximately the same size should be taken while emptying the storage. Avoid atypical material such as large chunks of bedding. After all the samples have been collected in the bucket, the manure should be placed on a tarp, piece of plywood, or clean concrete surface and mixed thoroughly. Take a subsample from the mixed composite sample and fill the lab manure sample container.

### Sampling During Spreading

Spread a tarp or sheet of heavy plastic in the field and spread manure over this with the manure spreader. Collect the manure from the tarp or plastic sheet and place it in the bucket. Repeat this procedure with a minimum of five spreader loads throughout the emptying of the storage. After all the samples have been collected in the bucket, the manure should be placed on a tarp, piece of plywood, or clean concrete surface and mixed thoroughly. Take a subsample from the mixed composite sample and fill the lab manure sample container. This procedure is usually only practical for more solid manures.

### Sampling Daily Haul

Place a five-gallon bucket under the barn cleaner four or five times while loading the spreader. After all the samples have been collected in the bucket, the manure should be placed on a tarp, piece of plywood, or clean concrete surface and mixed thoroughly. If the manure is too wet to mix on a tarp, plywood, or concrete surface, mix the manure thoroughly in the bucket. Take a subsample from the mixed composite sample and fill the lab manure sample container. Repeat this several times throughout the year to determine variability over time.

### Sampling Stockpiles

Sampling directly from manure, compost, or litter stockpiles as described here is not recommended because it is difficult to obtain a representative sample. Testing during loading or application as explained above is the preferred method. One sample may be adequate for smaller, more homogeneous piles or compost that has been "turned." Multiple samples should be taken from larger piles to represent the variability of the material in the piles. In uncovered piles, avoid taking samples from the weathered exterior of the pile. Volatilization can affect the surface levels of nitrogen and rainfall can leach water-soluble nutrients into the pile. Take ten to twenty samples from widely dispersed areas of the entire pile. Samples should be collected from at least 18 inches below the surface of the pile. A large diameter auger bit and portable drill or soil sampler can be used to access manure deep within pile. After all the samples have been collected in the bucket, the manure should be placed on a tarp, piece of plywood, or clean concrete surface and mixed thoroughly. Take a subsample from the mixed composite sample and fill the lab manure sample container.

### In-house Sampling Poultry Litter

The consistency and nutrient content of dry litter will vary across the poultry house. Material under and near waterers and feeders will be different from the rest of the house. Manure from the brood and grow-out areas represent different manure groups and should be sampled separately. Use a solid manure sampling probe to collect fifteen to twenty samples from throughout the house to the depth of the litter to be removed. Collect samples from around waterers and feeders proportional to the space they occupy in the house. After all the samples have been collected in the bucket, the manure should be placed on a tarp, piece of plywood, or clean concrete surface and mixed thoroughly. Take a subsample from the mixed composite sample and fill the lab manure sample container. A sample taken while loading the spreader or during spreading will be a more representative sample than the method described here.

### LIQUID MANURE SAMPLING PROCEDURES

In most liquid manure storages there is some stratification of solids and, as a result, nutrients. Therefore, storage agitation is critical to obtain a homogeneous manure mix. This is important for both obtaining a representative sample and spreading a uniform manure. Agitating for two to four hours is the minimum; however, depending on the type of storage, a much longer agitation time may be required. If manure is not properly agitated, nitrogen and potassium will typically concentrate in top liquid portion, while phosphorus will be more concentrated in the solids accumulated on the bottom. Length of agitation time for sampling should be similar to agitation time done before the storage is emptied. For this reason, the most practical time to sample is when the storage is being emptied for field application. If the storage is not adequately agitated, there will likely be manure consistency and nutrient stratification. Figure 2 illustrates how manure analysis can vary within a storage without adequate agitation. In this example, manure in the last fifteen loads spread from this storage has two to three times more phosphorus than in the first forty-five loads spread. If the storage is known to be stratified, separate

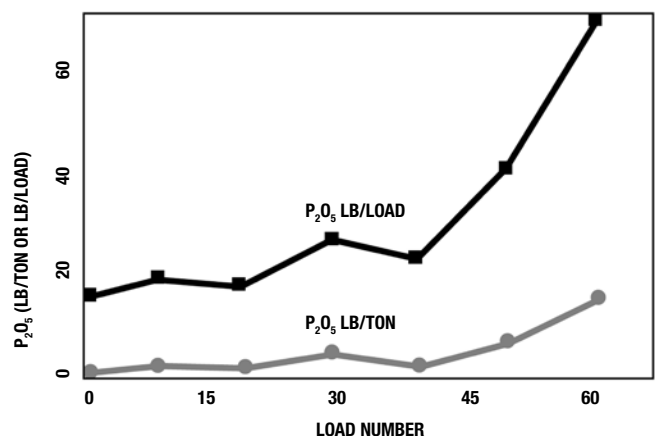

Figure 2. Variation in manure phosphorus analysis as a liquid swine manure storage is emptied.

Source: Les Lanyon, Penn State.

samples should be taken as the manure consistency or color changes during emptying.

The following sampling procedures can be used for liquid manure. The recommended procedures for liquid manure are to sample while loading the spreader or during application in the field.

### **Sampling During Loading**

Agitate the storage thoroughly before sampling. Collect at least five samples during the process of emptying the storage and loading the spreader. Save these samples in a bucket. When all of the samples have been collected, thoroughly mix the samples and take a subsample from this to fill the lab manure test container. Using a plunger with an up-and-down motion works well for mixing the manure in the bucket. If samples are collected over a period of several hours, store the bucket with manure samples on ice to prevent ammonia losses.

### **Sampling During Spreading**

This method can be used for spreader-applied manure, but it is strongly recommended for irrigated manure. Place buckets around the field to catch manure from the spreader or irrigation equipment. Place these to collect manure from more than one spreader load. Combine and mix the manure collected from different locations, and take a subsample from this to fill the lab manure test container. This method may give you “crop available ammonia nitrogen” as any ammonia losses may have already occurred prior to reaching bucket. What reaches the bucket is likely to soak into the soil and be available to the crop. If samples are collected over a period of several hours, store the bucket with manure samples on ice to prevent ammonia losses.

### **Sampling Directly from Storage**

Sampling a storage directly is much more difficult and likely to result in more variable results than sampling as the manure is loaded into the spreader. Agitate the storage thoroughly before sampling. Use a small bucket or tube to collect at least five samples from different locations in the storage. Combine these samples in a bucket, thoroughly mix the samples, and take a subsample from this to fill the lab manure test container. If samples are collected over a period of several hours, store the bucket with manure samples on ice to prevent ammonia losses.

## **SELECTING A LAB**

When selecting a manure analysis laboratory, it is best to ask some questions to ensure that you receive the information that you want at a competitive cost. This also allows the lab to best meet your needs. Following are six areas to explore with a manure analysis lab:

1. How many years has the laboratory been performing manure analysis? Labs should have at least two years of experience in manure testing.
2. Is the lab certified by an independent quality-control organization? The answer to this question should be “yes.” This ensures that the lab adheres to industry-sanctioned quality-control standards, which can help validate the results.

3. What manure analyses are included in the laboratory’s standard package?
4. How does the laboratory report its manure analysis results?
5. How are samples handled when they are received at the lab? The samples should be tested immediately. If that’s not possible, the samples should be refrigerated or treated to maintain their integrity until analyzed.
6. How long does a customer typically wait for results? Results should be compiled and delivered within a consistent and predictable amount of time.

One option, if testing manure for the first time, is to send exactly the same samples to at least three different labs so you can compare results. If results are similar, choose the lab that gives you the most value and service for your dollar. Remember, cheapest isn’t always best. Customer service is the hallmark of a reliable lab, so make sure you consider how well the lab lived up to its promises.

## **HANDLING AND SHIPPING SAMPLES**

Carefully follow all instructions from your manure testing lab for handling and delivering the samples to the lab. Proper care and handling of the sample will ensure that the samples sent for analysis are representative of the original manure nutrient content. Proper steps should be taken to avoid leakage, nutrient transformations such as volatilization, and moisture loss.

Liquid manure sample containers should never be filled more than three-quarters full. If using plastic bags, fill approximately one-half full, squeeze out the air, close, and seal. Samples should be double-bagged to prevent leaking.

Samples should be kept cool until they are sent to the lab. Most labs recommend freezing samples or keeping them on ice. Do not allow the samples to sit longer than one hour in a warm environment. Ideally, samples should be sent to the lab within a day. If they are not sent within a day, they should be frozen until shipped. It is best to send samples early in the week so they don’t arrive at the lab on weekends and holidays, causing them to sit around longer than desired. Be sure to clearly label the sample and completely fill out the lab information sheet that accompanies the sample.

## **RECOMMENDED TESTS**

Most labs have a basic manure test package with the option to add other tests for an additional fee. Make sure the tests or test package you select includes at least the following analyses for nutrient management planning:

- Percent moisture or percent solids
- Total nitrogen
- Ammonium-nitrogen (NH<sub>4</sub>-N)
- Total phosphorus (P)
- Total potassium (K)

Other analyses that may be useful in some situations include pH, carbon-to-nitrogen (C:N) ratio, water-extractable P, calcium carbonate equivalent, secondary nutrients (Ca, Mg, and S), and micronutrients (Cl, Na, Cu, Mn, Zn,

and Fe). Usually it is not necessary to analyze manure for nutrients such as Ca, Mg, Zn, and boron. Most manure contains significant amounts of these nutrients and fields with a history of manure application are rarely deficient.

### **MANURE TEST RESULTS CAN BE REPORTED DIFFERENTLY**

Manure analysis results can be reported in several different ways; therefore, it is important to clearly understand how the manure test results are reported.

#### **Dry Matter or As Sampled?**

The first consideration is whether the results are reported on an as-sampled basis or on a dry-matter or dry-weight (dwt) basis. Most agricultural labs that do manure testing report the results on an as-sampled basis. If the results are reported on a dry-weight basis, the analyses will have to be converted back to as sampled to be practical for use in a nutrient management plan. See the “Common Manure Test Results Conversions” section for example calculations to convert analyses results from percent dry weight (% dwt) or ppm to “as-is” results (lb/ton or lb/1,000 gal).

#### **Reporting Units**

A second consideration in reporting manure test results is the reporting units used by the laboratory. When results are reported on an as-sampled basis, the most common units used are lb/ton for more solid samples and lb/1,000 gallons for liquid samples. However, carefully check the units on the manure test because other units are sometimes used. For example, some labs report liquid manure test results in lb/100 gallons. Pounds/acre-inch may be preferred by producers using irrigation systems. Also, particularly when results are reported on a dry-weight basis, percent (%) and parts per million (ppm) may be used. See the “Common Manure Test Results Conversions” section for example calculations to convert analyses results from percent dry-weight (% dwt) or ppm to “as-is” results (lb/ton or lb/1000 gal).

#### **Elemental or Oxide?**

A third consideration is that phosphorus and potassium results may be reported in the elemental form as P and K, or in the oxide form as P<sub>2</sub>O<sub>5</sub> and K<sub>2</sub>O. Most agricultural labs that do manure testing report the results in the oxide form since this is how fertilizer recommendations are made. If the results are reported in the elemental form, they will have to be converted to the oxide form for use in nutrient management planning. See the “Common Manure Test Results Conversions” section for example calculations to convert analysis results from elemental to oxide.

#### **Solid or Liquid?**

Finally, there may be situations where the results are reported for a liquid manure (i.e., lb/1000 gal), but the manure is spread on a ton basis (i.e., tons/acre). The density of the manure can be used to convert the reported liquid analysis to a solid analysis. See the “Common Manure Test Results Conversions” section for example calculations to convert analysis results from liquid to solid or solid to liquid.

### **MANURE ANALYSIS RECORDS AND CREATING A BASELINE**

Manure nutrient analysis will vary from sample to sample on a farm, even with consistent management and careful sampling. Generally, a running average of manure analyses will better reflect manure nutrient content than any one sample result. Also, most of the sampling methods outlined here recommend sampling at the time the manure is being spread. This means that manure analysis results will not be available until after the manure is already spread. Therefore, nutrient management plans should be based on previous test results.

It is recommended to test manure annually for at least three years to establish a running average manure analysis that is used in the following year to develop the nutrient management plan. Table 1 illustrates how manure analysis records from a Pennsylvania dairy farm can be used to develop a useful manure analysis program. Only the N and solids analysis are shown here, but all test results would be analyzed similarly. In Table 1 the first three years are relatively consistent and the running average in the third column of this table would be used for planning the following year.

Once a baseline is established, less frequent manure testing may be acceptable. When a new manure analysis is obtained, it should be compared to the running average. If the new analysis is consistent with the average, it can be added to the running average. If there is an obvious trend—for example, manure analyses are slowly and consistently increasing or decreasing over time—the oldest value in the running average should probably be dropped when the new value is added.

If there is significant variation in the results, the following recommendations should be followed:

1. Extend the time frame for establishing a running average beyond the three years.
2. Try to identify the cause or causes of the variation.
3. Determine if management changes can be made to reduce the variation (e.g., better sampling, better agitation).
4. Determine if management changes can be made to react to the differences from year to year (e.g., increasing rates in a year when above-average rainfall dilutes the manure, adjusting rates based on changes in animal feeding).

If the new manure test result is very different from the running average, immediately try to determine the cause. Evaluate the sampling procedures, especially if there were no obvious management changes. Consider resampling the manure, if possible, to confirm or correct the inconsistent analysis. Look for management changes such as major changes in animal feeding, changes in dilution water in liquid manure (more or less rainfall, changes in washwater added, etc.), or changes in manure handling (manure scraped from barn floors more or less frequently, different bedding management, etc.). If the change was a one-time occurrence, do not add this test result to the running average.

In the example in Table 1, the value for Year 4 does not fit the trend. A review of the situation indicated that this was an abnormally dry year, thus there was less dilution from rainfall. Notice that the % solids were higher than previous levels, which is more evidence that the dry year was the cause. This value was not included in the running average. The farmer reduced his sidedress nitrogen (N) rate slightly that year to account for the higher N analysis and also lower yield potential because of the drought.

If a permanent management change was made, a new running average will need to be established based on more intensive sampling over a three-year period. For example, in Table 1 the N analysis changed dramatically for the sample in Year 8. In this case the farmer had made a major change in his feeding program, replacing corn with distillers grains. This would be consistent with the increased N in the manure. Since this was likely a permanent change, a new running average was started. Since the change in feeding management was known, some educated estimates about how this would affect the manure analysis were used to make adjustments in the nutrient management plan for Year 8 rather than using the existing running average.

Also, certain management adjustments may have to be made after manure application, such as applying more or less supplemental fertilizer to fields where the manure was spread. Plan to apply supplemental fertilizer after manure application has been completed and the actual manure nutrient application is known based on a current manure sample.

**Table 1. How manure analysis records from a Pennsylvania dairy farm can be used to develop a useful manure analysis program. Only the N and solids analysis are shown here, but all test results would be analyzed similarly.**

YEAR	MANURE TEST N (LB/1,000 GAL)	RUNNING AVERAGE N <sup>1</sup> (LB/1,000 GAL)	SOLIDS (PERCENT)
1	28	28	6.8
2	25	27	7.8
3	26	26	7.4
4	35 <sup>2</sup>	26	10.4
5	26	26	6.2
6	26	26	6.1
7	29	27	7.5
8	36 <sup>3</sup>	36	8.8
9	34	35	8.1
10	35	35	8.3

- Used to develop the nutrient management plan
- Value does not fit the trend. Example of one-time occurrence. See text for explanation.
- Value does not fit the trend. Example of permanent management change. See text for explanation.

## COMMON MANURE TEST RESULTS CONVERSIONS

**NOTE:** Phosphorus is used in these examples, but the calculations are the same for all nutrients.

### Converting manure analyses results from % dry weight (% dwt) or ppm to “as-is” results (lb/ton or lb/1,000 gal):

- lb/ton as sampled = (% solids/100) x (% analysis dwt/100<sup>1</sup>) x 2,000 lb/ton

or

- lb/1,000 gal = (% solids/100) x (% analysis dwt/1000) x (density<sup>2</sup> lb/gal x 1,000)

<sup>1</sup> For results in ppm, replace 100 with 1,000,000.

<sup>2</sup> To do this the density of the manure must be known. See the “Procedure for Estimating Manure Density” section.

#### Examples:

- Manure analysis: 10.5 percent solids, 1.4 percent P dwt  
(10.5% solids/100) x (1.4% P/100) x 2,000 = 2.9 lb P/ton
- Manure analysis: 10.5 percent solids; 14,000 ppm P dwt; manure density is 8.3 lb/gal (10.5% solids/100) x (14,000 ppm P/1,000,000) x (8.3 lb/gal x 1,000 gal) = 12.2 lb P/1,000 gal

### Converting Manure Analysis Results from Elemental to Oxide:

- Standard conversion factors: P x 2.3 = P<sub>2</sub>O<sub>5</sub>; K x 1.2 = K<sub>2</sub>O

#### Examples:

- Manure analysis: 2.9 lb P/ton  
2.9 lb P/ton x 2.3 = 6.7 lb P<sub>2</sub>O<sub>5</sub>/ton
- Manure analysis: 12.2 lb P/1,000 gal  
12.2 lb P/1,000 gal x 2.3 = 28.1 lb P<sub>2</sub>O<sub>5</sub>/1,000 gal

### Converting Manure Analysis Results from Liquid to Solid or Solid to Liquid:

To do this the density of the manure must be known. See the “Procedure for Estimating Manure Density” section.

- lb/ton = lb/1,000 gal ÷ (density lb/gal x 1,000) x 2,000 lb/ton

or

- lb/1,000gal = lb/ton x (density lb/gal x 1,000) ÷ 2,000

#### Examples:

- Manure analysis: 27.8 lb P<sub>2</sub>O<sub>5</sub>/1,000 gal;  
Manure density estimated at 8.3 lb/gal  
27.8 lb P<sub>2</sub>O<sub>5</sub>/1,000 gal ÷ (8.3 lb/gal x 1,000) x 2,000 = 6.7 lb P<sub>2</sub>O<sub>5</sub>/ton
- Manure analysis: 6.7 lb P<sub>2</sub>O<sub>5</sub>/ton;  
Manure density estimated at 8.3 lb/gal  
6.7 lb P<sub>2</sub>O<sub>5</sub>/ton x (8.3 lb/gal x 1,000) ÷ 2000 = 27.8 lb P<sub>2</sub>O<sub>5</sub>/1,000 gal

### **PROCEDURE FOR ESTIMATING MANURE DENSITY**

Manure density varies with moisture content primarily depending on the amount of bedding. Liquid manure density can vary from 8 to 9 lb/gal but will typically have a density around 8.3 to 8.5 lb/gal. Manure density can be easily estimated with a five-gallon bucket and a set of scales. To calculate a more accurate estimate of manure density, use the procedure below:

1. Weigh an empty five-gallon bucket. Record the weight in pounds.
2. Fill the five-gallon bucket with a typical sample of the manure and weigh the bucket and manure. Record the weight in pounds.
3. Subtract the weight of the empty bucket (Step 1) from the weight of the bucket with manure (Step 2). Record the weight of the manure in pounds.
4. Repeat Steps 2 and 3 at least five times and calculate an average weight. Record the average weight in pounds.
5. Divide the average weight by 5 to determine the density in pounds per gallon

*or*

6. Multiply the average weight by 1.5 to determine the density in pounds per cubic foot.

### **ADDITIONAL REFERENCES**

Manure Testing on Livestock and Environment Learning Center eXtension website:

[www.extension.org/pages/ Manure\\_Testing](http://www.extension.org/pages/Manure_Testing)

“Sampling Livestock Waste for Analysis,” in John Peters and Sherry Combs, *Recommended Methods of Manure Analysis*, [http://pubwiki.extension.org/mediawiki/files/a/a5/Unit\\_I\\_Sampling\\_Livestock\\_Waste\\_for\\_Analysis.pdf](http://pubwiki.extension.org/mediawiki/files/a/a5/Unit_I_Sampling_Livestock_Waste_for_Analysis.pdf).

Prepared by Jerry Martin, senior project associate, and Douglas Beegle, professor of agronomy.  
Development and printing of this fact sheet were supported by the Pennsylvania State Conservation Commission Nutrient Management Program.  
Much of the material in this fact sheet was adapted from a website authored by Douglas Beegle, Penn State, and John Peters, University of Wisconsin.

**extension.psu.edu**

Penn State College of Agricultural Sciences research and extension programs are funded in part by Pennsylvania counties, the Commonwealth of Pennsylvania, and the U.S. Department of Agriculture.

Where trade names appear, no discrimination is intended, and no endorsement by Penn State Extension is implied.

This publication is available in alternative media on request.

Penn State is committed to affirmative action, equal opportunity, and the diversity of its workforce.

Produced by Ag Communications and Marketing

© The Pennsylvania State University 2009

Code UC207 04/14pod