

EPA 903-R-12-001

February 2012

CBP/TRS 304-12

# **Guide to Using Chesapeake Bay Program Water Quality Monitoring Data**



**Chesapeake Bay Program**  
*A Watershed Partnership*

**February 01, 2012**

**Chesapeake Bay Program  
410 Severn Avenue  
Annapolis, Maryland 21403**

# **Guide to Using Chesapeake Bay Program Water Quality Monitoring Data**

**February 2012**

Prepared for

United States Environmental Protection Agency  
Chesapeake Bay Program  
410 Severn Avenue  
Annapolis, MD 21403

Prepared by

Chesapeake Bay Program Staff:  
Marcia Olson, under contract to the Interstate Commission on the Potomac River Basin

Reviewed and Edited by

Chesapeake Bay Program Staff:  
 Michael Mallonee, Interstate Commission on the Potomac River Basin  
 Mary Ellen Ley, United States Geological Survey

Also available as ICPRB Report 12-03

## TABLE OF CONTENTS

I. ABOUT THE GUIDE .....	2
PURPOSE	
FOCUS	
BACKGROUND	
II. CBP MAINSTEM AND TRIBUTARY MONITORING DATA .....	4
PROGRAM DESCRIPTION	
SAMPLING SCHEME	
WATER QUALITY PARAMETERS	
<u>Measured parameters</u>	
<u>Derived/calculated parameters</u>	
<u>Detection limits</u>	
QUALITY ASSURANCE (QA) .....	10
<u>Intra-organization QAQC</u>	
<u>Inter-organization QAQC</u>	
<u>Detection limits</u>	
<u>Access to below-detection-limit values</u>	
<u>Validity checks in the lab</u>	
<u>Validity checks in the Data Upload and Quality Assurance Tool (DUQAT)</u>	
DOCUMENTATION .....	11
III. ACCESSING WATER QUALITY DATA .....	13
ACCESSING DATA AND OTHER ONLINE RESOURCES THROUGH THE WEB	
<u>The Data Hub</u>	
<u>Contact/Help Information</u>	
RETRIEVING DATA .....	15
<u>Defining Data Selection Criteria</u>	
Types of Data	
Attributes	
Date Range	
Location	
Parameters	
DOWNLOADING THE DATA .....	18
EXAMPLES OF DATA RETRIEVAL FILES FROM THE DATA HUB (Tables 1-6) .....	19
THE DOWNLOADED DATASET – WHAT’S IN IT? .....	25
<u>Background</u>	
<u>Downloaded files</u>	
<u>Primary variables</u>	
<u>Identifier variables</u>	
<u>Corollary variables</u>	
IV. ABOUT THE VARIABLES AND PARAMETERS .....	28
Introduction to Data Analysis Issue Tracking System (DAITS) and details about the individual variables/parameters	
V. APPENDICES .....	96
APPENDIX 1 – Station Tables	
Station lists for Programs contributing data to the CIMS Water Quality Database	
APPENDIX 2 – WQ Programs .....	115
Water quality monitoring programs in the CIMS database	
APPENDIX 3 – Method Changes, Detection Limit .....	123
APPENDIX 4 – Data Analysis Issues Tracking System (DAITS) .....	143
A table of DAITS issue topics with reference numbers	
APPENDIX 5 – The CBP Volumetric Interpolator - Analysis and Display tool .....	148

## I. ABOUT THE GUIDE

### PURPOSE

The primary purpose of the User Guide is to enhance the information about the USEPA Chesapeake Bay Program (CBP) water quality database by providing details and insights about the data that come from users' experience in extracting, manipulating, analyzing and interpreting them.

### FOCUS

The User Guide focuses primarily on data from the CBP partners' water quality monitoring programs. The long-term, fixed-station monitoring programs, which began in 1984 under the umbrella of the CBP, provided the foundation for the water quality database and the source of the database's essential structure and design. The CBP bears primary responsibility or is the lead for these programs' design and implementation, as well as for data management and utilization. The CBP partners, therefore, have detailed knowledge of those data, such as the history of design, parameter and methodological changes and some stumbling blocks encountered by users.

The database also contains water quality data from other sources and programs in the Chesapeake watershed, all of which conform to the data management protocols of the Chesapeake Information Management System (CIMS) and which together form a single, relatively consistent database. Information about these other programs is provided here mainly to help the user navigate his/her choices in the data retrieval process and to make the user aware of additional content in the database. For more information about those programs and data, users can check the documentation available online and/or contact the relevant agencies directly.

The User Guide is a living document. Insights, inconsistencies, data entry errors and the like will certainly be revealed as water quality data collections continue and users examine and use the data in numerous applications. We ask that such discoveries be passed back to the Water Quality Data Manager at the Chesapeake Bay Program Office to be corrected and/or shared with others as appropriate.

### BACKGROUND

#### **Chesapeake Information Management System**

In 1996 the Chesapeake Executive Council adopted the Strategy for Increasing Basin-wide Public Access to Chesapeake Bay Information. This strategy called for partners in the Chesapeake Bay Program to develop and implement the Chesapeake Information Management System (CIMS). The intent of CIMS was to electronically link a variety of information about the Bay and rivers and make this information available electronically through the Internet to a variety of audiences. The information targeted for distribution through CIMS included technical and public information, educational material, environmental indicators, policy documents and scientific data.

As a result of the CIMS initiative the various federal, state, academic and non-governmental organizations worked to establish a system of distributed databases. Many of the data assets available through CIMS were hosted on the data originator's Internet sites. The intent was to provide a single location from which all data assets would be available.

### **Executive Order 13508**

On May 12, 2009, President Barack Obama signed an Executive Order that recognizes the Chesapeake Bay as a national treasure and calls on the federal government to lead a renewed effort to restore and protect the nation's largest estuary and its watershed.

The Executive Order called directs CBP partners to "identify the mechanisms that will assure that governmental and other activities, including data collection and distribution, are coordinated and effective, relying on existing mechanisms where appropriate".

In 2010, in response to the Executive Order, the partnership began development of the Chesapeake Data Enterprise (CDE) based on the CIMS foundation. The data enterprise shares many of the same principles of CIMS, but broadens the partnership to include new data exchange partners and new data themes. Additionally, the data enterprise effort seeks to upgrade data exchange methods, adopt new standards, and refresh partnership agreements based on newer technologies and approaches.

### **Chesapeake Bay Program Data Center**

The EPA CBP presently maintains a Data Center at its main office in Annapolis, Maryland. The Data Center provides data management, GIS, web development and technical support to program participants to accomplish the goals and objectives of the partnership. The Data Center manages computer hardware and software, provides user support and training for these computer resources, acquires and stores data sets and provides analytical support for CBP activities.

The CBP Data Center is one of many geographically distributed data centers in the Chesapeake Bay Watershed. Recipients of Data Center services are the CBP goal implementation teams, CBP resource managers and the watershed's scientific community and stakeholders.

## **II. CBP MAINSTEM AND TRIBUTARY MONITORING DATA**

The focus of the User Guide pertains to data produced through the Chesapeake Bay Program partners' water quality monitoring programs in the mainstem Bay and tidal tributaries. Insofar as other tidal and non-tidal monitoring programs have become aligned with the CBP monitoring programs and with one another, much of the information contained here may be relevant to the other programs' data in CIMS as well. See Appendix 2 for more about other related programs.

### **PROGRAM DESCRIPTION**

The CBP Monitoring Program is a federal and state partnership, and the states of Maryland (MDDNR) and Virginia (VADEQ) have the largest responsibility to oversee regular monitoring of the station networks in their tidal tributaries and in their respective portions of the Bay. The mainstem program began in June 1984 with water quality parameters measured at 49 stations once each month during the colder late fall and winter months and twice each month in the warmer months. The parameters included various forms of the nutrient elements such as nitrogen, phosphorus and carbon, a measure of the photosynthetic pigment chlorophyll\_a, silicon, suspended solids, and a measure of water clarity and/or turbidity, in addition to water temperature, conductivity, salinity, dissolved oxygen and pH. Over the years, the sampling schedule has changed, parameters have been dropped and added, and analytical methods have changed. State monitoring of the tributaries was already in progress in 1984, but with different objectives and program designs. It took some years and gradual changes to sampling protocols and analytical methods to integrate the programs so that data collection, data management and data analysis could yield a basinwide assessment of status, trends and processes. There are still a few major differences between the mainstem and tributary programs and/or between state programs. For example, most tidal tributary stations are sampled once per month. The tidal waters of the Potomac and Patuxent Rivers are exceptions; they are major tributaries with enhanced temporal coverage. The original program included the main Bay, the major tributaries and embayments and a number of smaller tributaries discharging directly to the Bay. In 1989, Virginia began a substantial expansion of its program by extending water quality monitoring into the Elizabeth River and its several branches.

### **SAMPLING SCHEME**

The sampling schemes of these programs are generally similar. At each station, a hydrographic vertical profile is made that includes measurements of water temperature, salinity, and dissolved oxygen among others, at approximately 1- to 2-m intervals through the water column. Water samples for laboratory chemical analysis (e.g., nutrients, pigments, suspended solids) are collected at strategic locations within the water column: from surface and bottom layers, and at depths representing upper (above pycnocline) and lower (below pycnocline) layers at deeper, estuarine stations where salinity stratification occurs. This is in contrast to freshwater stations and some current and historical monitoring programs where sample depths are fixed and predetermined.

### **WATER QUALITY PARAMETERS**

### **Measured parameters**

Table 7 is a list of water quality parameters monitored under the auspices of the CBP Monitoring Program. They are a subset of the full list of parameters in the CIMS database available in the online [Water Quality Data Dictionary](#). Most of the monitored parameters are relevant to both tidal and nontidal systems in the Chesapeake basin, i.e., relevant to the marine, estuarine and freshwater systems in the basin. However, some parameters are relevant only to one system or another, so a superficial survey of your data retrieval may indicate false ‘missing’ values or patchy geographic distribution. For example, salinity may be assumed to be zero at a fresh water station and therefore not measured and as a result not included among the parameters submitted for that station.

### **Derived/calculated parameters**

Certain useful parameters are available in the database that are not measured directly, but calculated from other directly measured parameters. For example, total nitrogen (TN) is obtained by summing the measured dissolved and particulate constituent parameters. Over time at the various analytical laboratories, a number of analytical methods have been used to identify different molecular forms of dissolved and particulate nitrogen, resulting, so far, in five different ways of determining total nitrogen. Method codes inform the user how TN concentration was obtained. Method codes for calculated parameters begin with the letter ‘D’ to indicate that they are derived, followed by a number code that indicates which constituents are used in the calculation. In the case of TN, the method codes are D01 through D05.

### **Detection limits**

The minimum detection limit (MDL) is the lowest concentration of a parameter that the measurement system can detect reliably. In the CBP database, when measurements are below the MDL, the VALUE of the parameter is set to the detection limit and the detection limit flag, QUALIFIER, is set to "<". Detection limits for many parameters have been lowered over the life of the program. A table of detection limits and applicable date ranges is available upon request. Appendix 3 contains a static version of the table and additional discussion of detection limit issues.

Some parameters also have upper detection limits. Most dissolved parameters can be diluted and re-analyzed when an upper limit is encountered, so these rarely result in censored values in the database, but exceptional cases do exist. However, particulate parameters analyzed directly from filters, e.g., particulate carbon (PC) and particulate nitrogen (PN) cannot be diluted and may result in upper limit censoring. Above detection limit values are flagged in the database by setting the value of QUALIFIER to ‘>’. SECCHI depth can have an upper detection limit when the disk is visible on the bottom. In that event, the detection limit is equal to station depth. This latter circumstance is seldom, if ever, flagged as such in the database. The user must check for that condition him/herself.

Users should be aware that calculated parameters can be derived from constituents with detection limit compromised values. In CIMS, if a calculated parameter includes one or more such constituents, then the value is flagged by setting the QUALIFIER variable to ‘>’ or ‘<’, depending on whether the constituent(s) is greater than the maximum detection limit or less than the minimum detection limit, respectively. In the case of below detection limit (BDL)

constituents, two alternative calculated values are offered and indicated by the letter suffix A or B in the method code: for alternative A, the BDL constituent's minimum detection limit is used as the value of the constituent; for alternative B, one-half the detection limit is used. In the case of above detection limit constituents, the maximum detection limit (which is the value as stored in the database) is used as the value of the constituent and the method code includes the suffix letter D. (Note: suffix letter C is not defined.) Once the values of the above or below detection level constituent(s) is set, then the operation of addition or subtraction proceeds.

The procedures and options used in CIMS and described above for calculated parameters with below detection components do not take into account the thinking of some statisticians regarding calculated parameters obtained by subtraction, e.g., such parameters as NO3F (NO23F minus NO2F) or particulate-P (PP) (TP minus TDP). These statisticians argue that the detection limit of subtracted parameters is better estimated by the sum of the constituent detection limits, not the difference, where the Method Detection Limit of the constituents are calculated by the analytical laboratories using 3x standard deviation, as is done by most if not all of the laboratories participating in the CBP monitoring programs. (See more on this in Appendix 3.) This discrepancy has few real-world consequences at present, since the subtracted parameters of interest in the CBP monitoring program rarely have all constituents below detection level concentrations.

### **Method Codes**

The examples below illustrate how method codes are used. To review, the initial letter of the method code indicates the following:

- 'L' = laboratory method;
- 'F' = a field measurement, i.e., a parameter measured with onboard instrumentation;
- 'D' = a derived parameter, calculated from constituent parameters in the database; and
- 'C' = a calculated parameter, but differs from a 'D'-coded parameter in that all necessary constituent parameter values are not available in the database for some reason and the value must be used as if it were a directly measured parameter.

The trailing letter or suffix indicates the following:

- 'A' = the true concentration or value of the constituent is below the minimum detection limit, the value in the database is the minimum detection limit and this value is used for the constituent;
- 'B' = the true concentration or value of the constituent is below the minimum detection limit, the value in the database is the minimum detection limit and one-half this value is used for the constituent;
- 'D' = the true concentration or value of the constituent is above the maximum detection limit, the value in the database is the maximum detection limit and this value is used for the constituent.

The first example below shows nitrogen parameters at station TWB01. NH4F, NO2F and TKNW are directly measured nitrogen parameters as indicated by their method codes beginning with 'L'. DIN (dissolved inorganic N) is a calculated parameter and is the sum of ammonium, nitrite and nitrate. In this case, the first 3 letters of the method code (D02) by definition indicate that it was derived from NH4F + NO2F + NO3F. The trailing letter D in D02-D indicates that at



least one of the constituents, in this case NH4F, is above the maximum detection limit. In the database, NH4F takes the value of the analytical lab's detection limit (in this case 1 mg/L), the value is flagged (QUAL='>'), and any calculated parameter using this value must include the suffix letter D appended to the method code. NO2F is the value as measured in the laboratory (method code L01) and equal to 0.041 mg/L. The method code for NO3F is C01, and the leading C indicates that this value was calculated at the originating laboratory (from NO23F - NO2F), but the directly measured value (NO23F) is not available in the CIMS database. In this example, TN is calculated and obtained using method D02, which is defined as TKNW + NO2F + NO3F.

STATION	DATE	DEPTH	LAYER	PARAM	QUAL	VALUE	UNIT	METHOD
TWB01	10/20/86	0.1	S	DIN	>	1.453	MG/L	D02D
TWB01	10/20/86	0.1	S	NH4F	>	1	MG/L	L01
TWB01	10/20/86	0.1	S	NO2F		0.041	MG/L	L01
TWB01	10/20/86	0.1	S	NO3F		0.412	MG/L	C01
TWB01	10/20/86	0.1	S	TKNW		1.98	MG/L	L02
TWB01	10/20/86	0.1	S	TN		2.433	MG/L	D02

In the next example, the detection limit flag for DIN (QUAL='<') indicates at least one of the constituents is below minimum detection limit. In this case, it is NH4F and here takes the detection limit, 0.003 mg/L, as its value in the database. DIN is calculated from NH4F + NO23F and here has two different values shown, one with NH4F at the detection limit (method D01A) and one using one-half the detection limit (D01B). Using method D01A, DIN is calculated from 1.71+0.003=1.713; using method D01B, DIN is calculated from 1.71+ (0.003/2)=1.7115. TN in this example is calculated from method D03: TDN + PN.

STATION	DATE	DEPTH	LAYER	PARAM	QUAL	VALUE	UNIT	METHOD
CB2.1	03/09/06	6.0	B	DIN	<	1.713	MG/L	D01A
CB2.1	03/09/06	6.0	B	DIN	<	1.7115	MG/L	D01B
CB2.1	03/09/06	6.0	B	NH4F	<	0.0030	MG/L	L01
CB2.1	03/09/06	6.0	B	NO23F		1.71	MG/L	L01
CB2.1	03/09/06	6.0	B	PN		0.127	MG/L	L01
CB2.1	03/09/06	6.0	B	TDN		1.97	MG/L	L01
CB2.1	03/09/06	6.0	B	TN		2.097	MG/L	D03

Note: It is important for the user to remember that CIMS data retrievals that include calculated parameters are likely to have these multiple values for the same parameter that are not independent measurements, and this can affect analyses. The user can exclude one or the other

of the alternative values or use an average of the two. Because below detection values can be treated in a variety of ways in addition to the two alternatives shown, the user may elect to select *Measured Parameter Values Only* and derive the parameters him/herself using their own rules for handling bdl values.

**Table 7.** Field and laboratory parameters. In general, measurements from whole water samples (*variablename-W*) are more typically found in nontidal datasets from past years. More recently, the nontidal agencies have adopted the filtered methodology used in the tidal programs with consequent changes in the submitted parameters (now mostly *variablename-F*). In the Non-Tidal column, X indicates that the parameter is unlikely to be in nontidal datasets, √ indicates a parameter unlikely to be in a tidal dataset.

Category	Parameter Name	Variable Name	Non-Tidal
PHOSPHORUS:	Total phosphorus*	TP	
	Total dissolved phosphorus	TDP	
	Particulate phosphorus*	PP	
	Orthophosphorus (whole, filtered))	PO4W, PO4F**	
	Dissolved inorganic phosphorus	DIP**	
	Dissolved organic phosphorus*	DOP	
NITROGEN:	Total nitrogen*	TN	
	Total dissolved nitrogen	TDN	
	Particulate Organic Nitrogen and Particulate Nitrogen*	PN	
	Total Kjeldahl nitrogen (whole, filtered)	TKNW, TKNF	
	Nitrite + nitrate (whole, filtered)	NO23W, NO23F	
	Nitrite (whole, filtered)	NO2W, NO2F	
	Ammonium (whole, filtered)	NH4W, NH4F	
	Dissolved inorganic nitrogen*	DIN	
	Dissolved organic nitrogen	DON	
	Total organic nitrogen*	TON	
CARBON:	Total organic carbon*	TOC	
	Dissolved organic carbon	DOC	
	Particulate organic carbon*	PC	
OTHER LAB			
PARAMETERS:	Silica (whole, filtered)	SIW, SIF	
	Total sulfate (whole)	SO4W	√
	Total suspended solids	TSS	
	Total dissolved solids	TDS	√
	Fixed suspended solids	FSS	√
	Chlorophyll a and pheophytin	CHLA, PHEO	
	Biological oxygen demand 5-day (whole, filtered)	BOD5W, BOD5F	√
	Total alkalinity	TALK	√
	Total coliform	TCOLI	√

Category	Parameter Name	Variable Name	Non-Tidal
	Fecal coliform	FCOLI	√
FIELD			
PARAMETERS:	Dissolved oxygen	DO	
	Dissolved oxygen saturation*	DO_SAT	
	PH	PH	
	Salinity	SALINITY	X
	Turbidity: Turbidimeter (Formazin units)	TURB_FTU	√
	Turbidity: nephelometric method	TURB_NTU	√
	Chlorophyll_a, fluorometric	CHLAF	
	Secchi disk depth	SECCHI	
	Light attenuation	KD	
	Specific conductivity	SPCOND	
	Specific gravity*	SIG_T	X
	Water temperature	WTEMP	
	Station depth	TOTAL_DEPTH	
	Upper/lower pycnocline depth (separate variables)	UPPER_/LOWER_ PYCNOCLINE	X
FIELD			
CONDITIONS:	Air temperature	AIR_TEMP	
	Cloud Cover	CLOUD_COVER	
	Tide stage	TIDE_STAGE	
	Wave height	WAVE_HEIGHT	
	Wind direction	WIND_DIRECTION	
	Wind speed	WIND_SPEED	

\*Now or were in the past calculated from other directly measured parameters. Users should check method codes and see section IV for constituent parameters and derivative equations.

\*\*PO4F is sometimes used interchangeably with DIP.

## QUALITY ASSURANCE (QA)

The goal of quality assurance is to provide the user with data of known high quality. The first stage of quality assurance is quality control (QC), which is performed by personnel at the analytical laboratory to ensure that data meet quality standards (Taylor, 1987). Quality assurance assessments for chemical analyses measure two quantities, precision and accuracy. Precision is the repeatability of measurements, and accuracy is the closeness of analytical measurements to a "true" value. CBP QA data include precision and accuracy comparisons within the same organization and among different organizations.

### **Intra-organization QAQC**

To assess within-organization precision and accuracy, approximately 10% of the chemical analyses for each parameter are analyzed in duplicate and spiked in the laboratories. Laboratory replicate and spike data are submitted to CBPO separately from monitoring data and are maintained in the TAB\_QAQC table in the CBP Water Quality Database. This data is available upon request. At some stations, field replicates are also generated, and these are reported with the regular monitoring data in the TAB\_DATA table.

For more QA information online, go to [About the BAY PROGRAM/Programs & Projects/Quality Assurance](#).

### **Inter-organization QAQC**

Inter-organization precision is assessed by the Coordinated Split Sample Program (CSSP), which includes comparisons of the results from field split samples analyzed by different laboratories. Inter-organization accuracy is assessed through [Blind Audit Samples and USGS reference samples](#).

### **Detection limits**

Detection limits were discussed above in connection with measured and calculated parameters. Detection limits are another aspect of quality assurance, thus some of those points are repeated here. The minimum Method Detection Limit (MDL) is the lowest concentration of a parameter that the measurement system can detect; therefore, measurements below this level are reported only as less than that limit. That is, in the CIMS database, the value of the parameter is set to the MDL and the value of the QUALIFIER variable is set to '<'. At participating CBP laboratories, the MDL is currently determined from 3.14 times the standard deviation of 7 replicates of a low-level ambient water sample. There are other methods of determining detection limits and detection limits for many parameters have been lowered over the life of the program due to improvements in analytical methods. A table of detection limits and the applicable date ranges for each laboratory is available upon request. Appendix 3 contains a static example of the table and additional discussion of detection limit issues.

### **Access to below-detection-limit (bdl) values**

A consequence of setting bdl values to the detection limit is that all such values are then equal to one another, when in reality they may not be, however small the difference. This has ramifications for statistical analysis and in order to avoid these artificial equalities, some users prefer to use the actual measured values, regardless of their bounded uncertainty. The actual bdl measurements are submitted to CIMS, but at present, access to them is permitted only to users whose analytical objectives demonstrably require them. Permission and access is currently

approved through the Water Quality Data Manager. The Data Manager may request information about the user's context, application and ultimate objectives before releasing the data. Some history and more discussion of this subject are in Appendix 3.

### **Validity checks in the lab**

Data quality issues are flagged using the PROBLEM variable and the appropriate code for quality control reasons. In most cases, the data value is retained, but sometimes and according to specified rules a data point is actually removed and accordingly noted in the PROBLEM code. The codes and rules have evolved over the life of the program. Problem codes and descriptions are maintained in the WQ\_PROBLEM table and can be found in the [Water Quality Data Dictionary](#) found in the water quality *Documentation* menu.

### **Validity checks in the Data Upload and Quality Assurance Tool (DUOAT)**

Data files are now submitted electronically to the CBPO by the participating agencies. Data collections funded fully or in part by the CBP have data submission requirements specified in the grant provisions. The partner agencies collecting data as part of the Chesapeake Bay Tidal Water Quality Monitoring Program submit data to the CBPO within 60 days of the end of the month in which the sample was collected. Other programs and data that are voluntarily submitted have other submission schedules.

[DUOAT](#) is an automated online facility that processes a data submission through format and other quality assurance checks, provides a report on errors and outliers and, after formal acceptance by the submitter and Water Quality Data Manager, loads the data into the CIMS database for access by the public. The final report from the QA checks is archived and available, should a data user think it useful. More information is available in the [CIMS Data Upload & Quality Assurance Tool User's Guide](#) found in the water quality *Documentation* menu.

## **DOCUMENTATION**

The CBP Monitoring Program participating agencies are required to submit documentation each grant year, which includes an overview of their monitoring program. In the early years, these were submitted as individual text files and there was much variability and inconsistency among data submitters in document content and thoroughness. The old project files are archived and can be made available through the Water Quality Data Manager. Project/program documentation provides such information as

- project title;
- project beginning and ending date, and sampling schedule;
- EPA QA/QC officer, EPA project officer, and EPA project number;
- principal investigator, project manager, QA/QC manager, and Data Manager;
- administrative organization, collecting organization, and analytical laboratory;
- project summary;
- parameter list;
- station table and station description; and,
- data entry and verification methods.

All federally funded organizations performing sampling, analysis and data analysis as part of the tidal and watershed monitoring networks have EPA-approved quality assurance plans and standard operating procedures that conform to the [CBP Recommended Guidelines for Sampling and Analysis](#). The guidelines specify sampling and analytical methods, precision and accuracy checks and tolerances, and documentation requirements. The quality assurance documents for individual partner organizations responsible for components of the larger the tidal and watershed water quality monitoring networks are available on the CBP partnership website at [Quality Assurance: Tidal Water Quality Monitoring - Chesapeake Bay Program](#) .

Monitoring Program participants were also originally required to submit data set documentation (DSDOC) with every data submission. This file provided such information as:

- changes made since last submission;
- sampling dates and cruise number;
- information on method and method detection limit (MDL) changes;
- parameter methods table, and;
- notes from cruise and laboratory logs; and
- results of the routine CBPO range-checking procedure.

These early text files have been archived, but are available through the Water Quality Data Manager.

Quarterly reports are submitted to the CBPO that provide additional information such as the reason why some stations were not sampled and changes in methods or procedures. Quarterly reports are generally not available to the user, but pertinent information from these reports has been included in this Guide. In many cases, significant issues are flagged and described in the DETAILS field of the EVENT table.

The Data Analysis Issues Tracking System ([DAITS](#)) is used to collect information and achieve consensus on analytical and other issues affecting data analysis. This procedural system is used to solicit information and track the resolution of analytical method, data analysis and data management issues that arise. The system is a collection of digital text files in consistent format including, among other things, an issue summary, resolution or resolution plan, if any; related issues; name of lead person(s) for the issue. See Appendix 4 for titles of submitted issues. Contact the Water Quality Data Manager for more information.

### III. ACCESSING WATER QUALITY DATA

A major objective of the Chesapeake Bay Program is to make data and information about Chesapeake Bay readily accessible to the public. The Internet has made access to the CBP water quality database relatively easy for those who have access to computers, and users who have fast connectivity will probably access and download water quality data themselves through the CBP website. Where web access is not the best option, users may request data from the CBP Water Quality Data Manager using the contact information given below. This Guide will help users define their data requests and provide them and the Data Manager some common ground on which to proceed.

#### ACCESSING DATA AND OTHER ONLINE RESOURCES THROUGH THE WEB

##### **The Data Hub**

The water quality monitoring database is accessed through the CBP website at [www.chesapeakebay.net](http://www.chesapeakebay.net). On the CBP homepage, among the tabs across the top, find and click on *Bay Resource LIBRARY*. Just below the tabs across the top are various topics included in the *LIBRARY* and brief content summaries of each topic are found further down the page. *Bay Data* is one of the topics and clicking on the link will take you to the [Data Hub](#). Scroll down the page and click on *Data Downloads* to shortcut to Databases or continue scrolling past descriptions of Data Programs to the database listings. Water quality databases are listed first, and the third in the list is the CBP Water Quality Database (1984-present) on which this user guide is focused. (Be aware that information technology changes rapidly and the user may encounter something different from what is described above. Use the site's Search tool or contact the Water Quality Data Manager to get back on track.)

In addition to the CBP Water Quality Monitoring Program, there are other contemporary and pre-1984 historical water quality data housed at the Hub, as well as biological and other kinds of environmental data. Data dictionaries, database design and other documentation are available for those databases and accessible by clicking on the dataset of interest and "drilling down" through the web offerings.

In context of this guide, select "CBP Water Quality Database (1984-present)" from the list of databases. At this portal, the user can go directly to the *Download Data* option or scroll down to find various forms of documentation including, among other things, station maps, the *Water Quality Data Dictionary*, *Water Quality Database Design and Data Dictionary*, and an earlier version of the user guide. These documents provide information on basic structure of the contemporary database, sampling locations, monitored parameters, valid values for the corollary variables accompanying the monitored parameters and much more.

The previous version of the user guide ["Guide to Using Chesapeake Bay Program Water Quality Monitoring Data" CBP/TRS 78/92 March 1993], although outdated in many respects, includes topical details that have been omitted from this version in light of the extensive reference resources available at the Data Hub and elsewhere on the CBP website. Detailed information about past laboratory quality assurance performance is one example.



### **Contact/Help Information**

Contacts for the various data collecting and submitting institutions are available in the online “[Water Quality Data Dictionary](#)” listed under water quality *Documentation*. Click on the Data Dictionary and select *Agency* from the dropdown list. For most agencies, there is both a Contact and a Data Manager listed, but phone numbers and email addresses are not provided. These can usually be obtained by online searches of the agency websites. For additional help, contact the CBP Water Quality Data Manager at 800-YOUR-BAY, ext 75785.

## RETRIEVING DATA

The Water Quality Database is very large and ever expanding, so it is important to narrow a data retrieval query to include only the desired data. The user must provide selection criteria for the type of data, the range of dates, station name(s) or other spatial specifications and desired parameters. After selecting the database *CBP Water Quality Database (1984-present)*, users who already know the specifics of their retrieval requirements may move directly to the selection criteria page by clicking on “Download Data” near the top of the page. Others may want to access materials in the *Documentation* menu to research selection options before proceeding. Specific reference documents are suggested in context below.

### Defining Data Selection Criteria

#### **Selection 1: Types of Data**

*Types of Data* is the first selection menu encountered at the data access portal (select only one per retrieval). The following information is also available by clicking the link “type of data” at this menu page. See example outputs in Tables 1 through 5.

- **Station Information**—static information about the site, e.g., site description, segment, lat/long and utm coordinates, hydrologic units (HUC\*) and FIPS (state/county).
- **Monitoring Event Data**—information about a particular sampling event, such as station, date, time, sampling event number, cruise number, station depth, depth of the pycnocline (if any), weather, etc.
- **Water Quality Data**—station, date, time, sample depth, layer, replicate id, parameter values (physical/chemical, clarity, nutrient, pigment, sediment parameters), method code, units, data problem code (if any), etc.
- **Light Attenuation Data**—raw measurements of photosynthetically active radiation (PAR) for calculating light attenuation (Kd): station, date, time, replicate id, PAR at surface, depth, PAR at depth, etc. These values are used to calculate the light attenuation coefficient (Kd) using the equation  $Kd = \ln(\text{PAR at surface} - \text{PAR at depth}) / \text{depth [m]}$ . The calculated value for Kd is among the parameters available by selecting data type: Water Quality Data, above.
- **Optical Density Data**—spectrophotometric measurements of optical density for calculating chlorophyll, other phytopigment concentrations and pheophytin: station, date, time, replicate id, depth, sample volume, extract volume, light path, optical density readings *before acidification* (indicated by letter B) at wavelengths 480, 510, 630, 645, 663, 664, and 750, and *after acidification* (indicated by letter A) at wavelengths 663 and 750. The calculated values for corrected chlorophyll a (CHLA) and pheophytin (PHEO) are among the parameters available by selecting Data Type: Water Quality Data, above.
- **Dynamic User-defined Graph**—an interface to create a custom graphical representation (line graph) of water quality statistics for user-defined monitoring station, parameter, date range, and water column layer(s).

## Selection 2: Attributes

For all *Data-Type* selections, except for the dynamic graph, the user is then asked to select particular geographic *Attributes* of the desired retrieval. Depending on the attribute, the user is presented with an appropriate menu to further subset the request. The following information and additional details are available by clicking the link “attribute” on this menu page.

- **Hydrologic Unit (HUC)**—A unit in a coding system developed by the United States Geological Survey that assigns drainage areas throughout the nation to a particular region, sub-region, accounting unit and cataloging unit. Cataloging units, or 8-digit hydrologic units (HUC8) as they are commonly called, delineate small to medium sized drainage areas. The Chesapeake Bay watershed is located entirely within region 02, the Mid-Atlantic Region. Within this region, there are 4 sub-regions that are at least partially comprised of drainage areas within the Chesapeake Bay watershed:
  - 0205 – Susquehanna River basin in Maryland, Pennsylvania and New York;
  - 0206 – Upper Chesapeake Bay and its tributary drainage north of the MD-VA state line;
  - 0207 – Potomac River basin in the District of Columbia, Maryland, Pennsylvania, Virginia and West Virginia;
  - 0208—Lower Chesapeake Bay and its tributary drainage south of the MD-VA state line.Note that Chincoteague and Eastern Lower Delmarva are outside the Chesapeake watershed; they are part of the Atlantic coastal drainage. Also note that in the context of the water quality database, the term watershed applies to drainage regions of various scales, from the entire Chesapeake Bay watershed to the sub-watersheds of smaller rivers and creeks. In some contexts, *watershed* is used synonymously with *basin*. In the station table referenced above, various basin and watershed assignments are given
- **Small Watershed (HUC11)** – additional codes partition the drainage areas into smaller units so that small watersheds can be identified for each station
- **County/City (FIPS)** -- the Federal Information Processing System (FIPS) assigns 5-digit codes to all counties and incorporated cities in the United States. The first two digits correspond to the state and the last three to the county or incorporated city within that state.
- **Monitoring Station**—Note: A list of all stations in the CIMS water quality database can be accessed via a link on the water quality database page: select “Water Quality Data Dictionary” from the *Documentation* menu; select “Station” from the dropdown list [[link](#)]. A static version of the table is in Appendix 1, Table 1, along with other variations (subsets) of the table, including stations in the CBP basinwide water quality monitoring program (Table 2). A map showing the location of the CBP monitoring program stations is also available in the water quality *Documentation* menu [[link](#)].
- **Monitoring Segment**—Note: A map of current (2003 version) CBP segments is available under *Bay Resource Library /Maps/Category=Health* [[link](#)]. The monitoring segment to which a station belongs is in Appendix 1, Table 1. More about the current segmentation scheme and other versions can be obtained in “Chesapeake Bay Program Analytical Segmentation Scheme” [[link](#)] from the water quality *Documentation* menu.
- **Water Body**—refers to the body of water in which the monitoring station is located.

## Selection 3: Date Range

On the same page, the user has 2 options to specify the date range for the data retrieval.

- Enter beginning and end dates within the 5-year limit per retrieval, -OR-
  - Enter particular seasons or time periods defined by consecutive months within the data range.
- If more than 5 years of data are desired, separate downloads for each 5-year set must occur. The 5-year limit is hard-wired in the data access software to avoid excessively large data packets. However, it can easily happen that even much smaller date ranges result in data packets that exceed the CIMS data handling requirements. For example, if a user wants all water quality parameters from all stations, or at least from so many stations that it is too cumbersome to specify them individually, then the retrieval may have to be done in 2-month packets. The user may have to use trial and error to find the date range that can accommodate his/her needs and make multiple separate downloads.

*Water Quality Programs:* On this web page is also a listing of the temporal extent for the water quality programs that submit data to CIMS. The table is automatically updated with the range of dates for which data are available. A static example of the table is given in Table 6.

Note: Currently, the user does not have the option of defining the data retrieval by specifying a particular program, although knowledge of the program(s) may be important to the user in developing data selection criteria. Each program is described in the water quality [Metadata](#) section documentation and briefly in Appendix 2.

**Be sure to select “Continue” to move on for more criteria selection.**

#### **Selection 4: Location**

*Stations/Segments:* Based on the preceding selections, the user then selects stations, monitoring segments or other level of geographic aggregation. The user may select one or more entities from the dropdown menu (hold down Ctrl and click on choices) or may select *All Stations/Monitoring segments/etc.*

#### **Selection 5: Parameters**

The user is then asked to select the desired water quality parameters. The user may select a single parameter or multiple parameters (hold down Ctrl and click on choices) from the dropdown list, or may select *All Parameters* or *Measured Parameter Values Only*.

There are 2 kinds of parameters:

- *Measured*—data collected by meter or laboratory analysis, and
- *Derived* – data created by adding or subtracting directly measured parameters.

Both parameter types are available for retrieval through CIMS. For example, DIN (dissolved inorganic nitrogen) is a parameter of great interest that is not measured directly, but obtained by adding together the directly measured constituents, NO23F (nitrate-nitrite) and NH4F (ammonia). TP (total phosphorus) is an example of a different situation: it is present in the database both as a directly measured parameter and as obtained from the addition of TDP (total dissolved phosphorus) and PP (particulate phosphorus). A separate Method variable indicates whether the parameter is measured (and by what field or analytical method) or derived. For various reasons, some users prefer to retrieve only directly measured parameters and to derive the computed parameters themselves. With that in mind, the option to retrieve *Measured Parameter Values Only* is offered as an overlay to the user-specified list and *All-parameters*

selection options.

The parameters tracked in the CBP Water Quality Monitoring Program are included in the [Water Quality Data Dictionary](#) and listed in Table 7. The section below also includes additional details about derived parameters in CIMS.

## **DOWNLOADING THE DATA**

This is the final step of the online process. If you have never downloaded data from CIMS, click the “Create your Data Retrieval Profile” button, fill out the few lines of information requested, and click *Submit*. The information is used by the CBP to track the number of data users and to be able to contact users should a database problem of sufficient magnitude warrant such communication. This information is neither sought by nor shared with any other entity.

Next, the user designates the name and destination of the file to be downloaded. There is also an option to store the retrieval selections for future similar retrievals. Follow the instructions provided.

## **EXAMPLES OF DATA RETRIEVAL FILES FROM THE DATA HUB**

Tables 1 – 5 below show examples of CIMS data retrievals using queries of different Data Types found in the database.

Table 1. Example of a CIMS retrieval file with selections Data Type=*Station*, Attribute=*Station* and Stations=*WT1.1 and WT2.1*.

Note: In the context of the water quality database, the term *watershed* applies to drainage regions of various scales, from the entire Chesapeake Bay watershed to the sub-watersheds of smaller rivers and creeks. In some contexts, *watershed* is used synonymously with *basin*. In the station table various basin and watershed assignments are given for each station

STATION	DESCRIPTION	WATER BODY	CBP BASIN	TS BASIN*	BASIN	CBSEG_2003	CBSEG_2003 DESCRIPTION	HUC8	CATALOG UNIT	HUC11
WT1.1	BUSH RIVER; EAST OF GUM POINT AT FLG LT; SALINITY TRANSITION	BUSH RIVER	MD WESTERN SHORE	UPPER WESTERN SHORE	BUSH RIVER	BSHOH	BUSH RIVER; EAST OF GUM POINT AT FLG LT; SALINITY TRANSITION	02060001	BUSH RIVER; EAST OF GUM POINT AT FLG LT; SALINITY TRANSITION	293
WT2.1	GUNPOWDER RIVER; 200 YARDS EAST OF OLIVER POINT AT BUOY G-"15"; SALINITY TRANSITION	GUNPOWDER RIVER	MD WESTERN SHORE	UPPER WESTERN SHORE	GUNPOWDER RIVER	GUNOH	GUNPOWDER RIVER; 200 YARDS EAST OF OLIVER POINT AT BUOY G-"15"; SALINITY TRANSITION	02060003	GUNPOWDER RIVER; 200 YARDS EAST OF OLIVER POINT AT BUOY G-"15"; SALINITY TRANSITION	309

WATERSHED	FIPS	STATE	COUNTY/CITY	FALL LINE**	LATITUDE	LONGITUDE	LL DATUM	UTM X	UTM Y
BUSH RIVER	4025	MD	HARFORD	B	39.43344	-76.24134	NAD83	393167	4365613
GUNPOWDER RIVER	24005	MD	BALTIMORE	B	39.383442	-76.34162	NAD83	384454	4360187

\*TS\_BASIN is basin assignment for Tributary Strategy purposes.

\*\*The fall line is the boundary between the Piedmont Plateau and the Coastal Plain, ranging from 15 to 90 miles west of the Bay. Waterfalls and rapids clearly mark this line. It also is the head of tide and commonly is the point at which the waters of the myriad small waterways of the upper watershed have conjoined to enter the tidal (and estuarine) tributaries leading to the Bay. A=above fall line; B=below fall line.

Table 2. Example of a CIMS retrieval file with selections Data Type=*Event*, Attribute=*Station* and Stations=*WT4.1 and WT5.1*.

EVENT ID	SOURCE	AGENCY	PROGRAM	PROJECT	STATION	EVENT START DATE	EVENT START TIME	CRUISE	TOTAL DEPTH	UPPER PYCNOCLINE	LOWER PYCNOCLINE
146294	MDDNR	MDDNR	WQMP	TRIB	WT4.1	3/8/2006	10:25	BAY434	1.8		
146897	MDDNR	MDDNR	WQMP	TRIB	WT5.1	4/4/2006	9:30	BAY436	15.2	9.5	12.5

AIR TEMP	WIND SPEED	WIND DIRECTION	PRECIP TYPE	TIDE STAGE	WAVE HEIGHT	CLOUD COVER	GAGE HEIGHT	PRESSURE	FLOW STAGE	DETAILS
	7			FLOOD TIDE	0.0 TO <0.1M	SCATTERED TO PARTLY CLOUDY (10-50%)				
	8	N		FLOOD TIDE	0.3 TO <0.6M	CLEAR (0-10%)				

Table 3. Fabricated fragment of a typical “data” file downloaded from CIMS with Data Type=**Water Quality Data**, Attribute=**Monitoring Station**, Parameter=**All parameters** selected. Note replicate values for surface TDN identified by Sample\_ID=S1 and S2; below-detection-limit status of surface TSS indicated by Qualifier='<', layer='S' assigned to both depth=0 and depth=0.5 m; and two different layer assignments (Layer='BP' and 'B') for depth=15 m. To conserve space here, Event, Lat and Long have no data shown. See text and recommended links for more explanation of variable names and valid codes and values.

EVENT_ID	SOURCE	PROJECT	STATION	SAMPLE_DATE	SAMPLE_TIME	DEPTH	LAYER	SAMPLE_TYPE	SAMPLE_REP_TYPE	PARAMETER	QUALIFIER	REPORTED_VALUE	UNIT	METHOD	LAB	PROBLEM	DETAILS	TOTAL_DEPTH	UPPER_PYCNOCLINE	LOWER_PYCNOCLINE	LAT	LONG
xx	MDDNR	TRIB	EX1.1	11/12/06	09:47	0S		ISM	M1	SECCHI		1.3	M	F01				16	12.5	13.5	x	y
xx	MDDNR	TRIB	EX1.1	11/12/06	09:47	0.5S		D	S1	TDN		1.09	MG/L	L01	CBL			16	12.5	13.5	x	Y
xx	MDDNR	TRIB	EX1.1	11/12/06	09:47	0.5S		D	S2	TDN		1.08	MG/L	L01	CBL			16	12.5	13.5	x	Y
xx	MDDNR	TRIB	EX1.1	11/12/06	09:47	0.5S		ISM	M1	WTEMP		13.6	DEG	F01				16	12.5	13.5	x	Y
xx	MDDNR	TRIB	EX1.1	11/12/06	09:47	0.5S		D	S1	TSS	<	3.0	MG/L	L01	CBL			16	12.5	13.5	x	Y
xx	MDDNR	TRIB	EX1.1	11/12/06	09:47	1M		ISM	M1	WTEMP		13.6	DEG	F01				16	12.5	13.5	x	Y
xx	MDDNR	TRIB	EX1.1	11/12/06	09:47	3M		ISM	M1	WTEMP		13.6	DEG	F01				16	12.5	13.5	x	Y
xx	MDDNR	TRIB	EX1.1	11/12/06	09:47	5M		ISM	M1	WTEMP		13.6	DEG	F01				16	12.5	13.5	x	Y
xx	MDDNR	TRIB	EX1.1	11/12/06	09:47	7M		ISM	M1	WTEMP		13.8	DEG	F01				16	12.5	13.5	x	Y
xx	MDDNR	TRIB	EX1.1	11/12/06	09:47	9M		ISM	M1	WTEMP		14.1	DEG	F01				16	12.5	13.5	x	Y
xx	MDDNR	TRIB	EX1.1	11/12/06	09:47	10M		ISM	M1	WTEMP		14.1	DEG	F01				16	12.5	13.5	x	Y
xx	MDDNR	TRIB	EX1.1	11/12/06	09:47	11AP		ISM	M1	WTEMP		14.2	DEG	F01				16	12.5	13.5	x	Y
xx	MDDNR	TRIB	EX1.1	11/12/06	09:47	11AP		D	S1	TDN		1.02	MG/L	L01	CBL			16	12.5	13.5	x	Y
xx	MDDNR	TRIB	EX1.1	11/12/06	09:47	11AP		D	S1	TSS		6.2	MG/L	L01	CBL			16	12.5	13.5	x	Y
xx	MDDNR	TRIB	EX1.1	11/12/06	09:47	12M		ISM	M1	WTEMP		14.3	DEG	F01				16	12.5	13.5	x	Y
xx	MDDNR	TRIB	EX1.1	11/12/06	09:47	13M		ISM	M1	WTEMP		14.4	DEG	F01				16	12.5	13.5	x	Y
xx	MDDNR	TRIB	EX1.1	11/12/06	09:47	14M		ISM	M1	WTEMP		15	DEG	F01				16	12.5	13.5	x	Y
xx	MDDNR	TRIB	EX1.1	11/12/06	09:47	15BP		ISM	M1	WTEMP		15	DEG	F01				16	12.5	13.5	x	Y
xx	MDDNR	TRIB	EX1.1	11/12/06	09:47	15BP		D	S1	TDN		1.03	MG/L	L01	CBL			16	12.5	13.5	x	Y

Table 4. Example of a CIMS retrieval file with selections Data Type=**Light Attenuation Data**, Attribute=**Station** and Station=**WT5.1**. There are several methods of determining KD; see text for discussion. Note sample time is not uniform for the Event. The value for KD that is calculated from these data is obtained from a Data Type=**Water Quality Data** retrieval.



EVENT ID	SOURCE	PROJECT	STATION	SAMPLE DATE	SAMPLE TIME	SAMPLE REP TYPE	DEPTH	EPARS	EPARU Z	EPARD Z
146295	ANS	TRIB	WT5.1	3/7/2006	8:10	M1	0.1	657.91	502.41	
146295	ANS	TRIB	WT5.1	3/7/2006	8:10	M1	0.5	651.21	252.11	
146295	ANS	TRIB	WT5.1	3/7/2006	8:10	M1	1.0	707.41	79.701	
146295	ANS	TRIB	WT5.1	3/7/2006	8:11	M1	1.5	828.61	81.311	
146295	ANS	TRIB	WT5.1	3/7/2006	8:11	M1	2.0	601.91	34.921	

UNIT	METHOD	DETAILS	TOTAL DEPTH	UPPER PYCNOCLINE	LOWER PYCNOCLINE
UM/M**2/S	F01		15.4	1.5	3.5
UM/M**2/S	F01		15.4	1.5	3.5
UM/M**2/S	F01		15.4	1.5	3.5
UM/M**2/S	F01		15.4	1.5	3.5
UM/M**2/S	F01		15.4	1.5	3.5

Table 5. Example of a CIMS retrieval file with selections Data Type=*Optical Density Data* for calculating chlorophyll pigment, Attribute=*Station* and Station=WT5.1. Note that depth=0.5 is associated with two layers, 'S' and 'AP'. The value for CHLA that is calculated from these data is obtained from a Data Type=*Water Quality Data* retrieval.

EVENT ID	SOURCE	PROJECT	STATION	SAMPLE DATE	SAMPLE TIME	DEPTH	LAYER	SAMPLE TYPE	SAMPLE REP TYPE	SAMPLE VOL	EXTRACT VOL	LIGHT PATH	OD 480B	OD 510B	OD 630B
146295	MDDNR	TRIB	WT5.1	3/7/2006	7:44	0.5	S	D	S1	0.25	14	5			0.062
146295	MDDNR	TRIB	WT5.1	3/7/2006	7:44	0.5	AP	D	S1	0.25	14	5			0.065
146295	MDDNR	TRIB	WT5.1	3/7/2006	7:44	5.0	BP	D	S1	0.25	14	5			0.064
146295	MDDNR	TRIB	WT5.1	3/7/2006	7:44	14.4	B	D	S1	0.25	14	5			0.059

OD 645B	OD 647B	OD 663A	OD 663B	OD 664B	OD 665A	OD 750A	OD 750B	LAB	PROBLEM	DETAILS	TOTAL DEPTH	UPPER PYCNOCLINE	LOWER PYCNOCLINE
0.055	0.062		0.217	0.218	0.131	0.006	0.005	MDHMH			15.4	1.5	3.5
0.057	0.065		0.227	0.227	0.142	0.007	0.006	MDHMH			15.4	1.5	3.5
0.055	0.062		0.213	0.215	0.132	0.008	0.007	MDHMH			15.4	1.5	3.5
0.054	0.061		0.210	0.212	0.137	0.006	0.007	MDHMH			15.4	1.5	3.5

Table 6. The Data Hub provides a listing of projects and date ranges to inform the data retrieval. End dates in this table indicate the latest available data record for discontinued projects. Projects in this table without an end date indicate ongoing projects.

<b>AGENCY</b>	<b>PROJECT</b>	<b>START DATE</b>	<b>END DATE</b>
CBNERRS	CONTINUOUS MONITORING	3/8/2004	12/1/2005
DCDOH	CHESAPEAKE BAY TRIBUTARY MONITORING	1/16/1984	
IHDNSWC	CHESAPEAKE BAY TRIBUTARY MONITORING	4/26/2000	8/23/2004
MDDNR	CHESAPEAKE BAY MAINSTEM MONITORING	7/10/1984	
MDDNR	CHESAPEAKE BAY TRIBUTARY MONITORING	7/11/1984	
MDDNR	CONTINUOUS MONITORING	4/2/2003	
MDDNR	DATAFLOW MONITORING	4/28/2003	
MDDNR	SPECIAL STUDY	8/6/2001	10/18/2002
NCBO	CONTINUOUS MONITORING	3/19/2004	12/2/2004
NCBO/NCPO	DATAFLOW MONITORING	3/23/2004	11/3/2005
NFWF	CHESAPEAKE BAY TRIBUTARY MONITORING	7/11/2002	12/2/2002
SMCM	CHESAPEAKE BAY TRIBUTARY MONITORING	4/27/1999	3/30/2006
SMCM	NON-TIDAL MONITORING	7/8/1999	10/10/2006
SRBC	NON-TIDAL MONITORING	10/19/1984	
USGS	CHESAPEAKE BAY TRIBUTARY MONITORING	8/16/1988	4/3/1991
VADEQ	CHESAPEAKE BAY MAINSTEM MONITORING	6/27/1984	
VADEQ	CHESAPEAKE BAY TRIBUTARY MONITORING	7/11/1984	
VADEQ	CONTINUOUS MONITORING	3/18/2004	
VADEQ	DATAFLOW MONITORING	5/12/2003	
VADEQ	NON-TIDAL MONITORING	2/6/2001	
VADEQ	SPECIAL STUDY	2/6/2001	12/28/2006
VIMS	DATA-FLOW MONITORING	3/16/2006	

## THE DOWNLOADED DATA SET – WHAT’S IN IT?

### **Background**

CIMS stores water quality data in a relational database that is more fully described in the “[Water Quality Database Design and Data Dictionary](#).” It isn't necessary to understand the architectural structure of the database design in order to access and use the data, but it may help to explain what kinds of data and related information are provided from the data retrieval selection process described above, what additional information is available and how the user can correctly and efficiently join the separate pieces of information together.

Briefly, in the CBP Water Quality Database, monitoring information is grouped in subsets (‘tables’) that are related to one another through common elements. The current list of primary tables includes TAB\_CRUISE, TAB\_EVENT, TAB\_STATION, TAB\_DATA, TAB\_CHLOROPHYLL, TAB\_KD, and TAB\_QAQC. Information related specifically to monitoring stations (e.g., latitude, longitude, segment, basin, etc) is stored in the Station table. Information collected at a group of stations over a period of time that should be associated with each other to provide a synoptic characterization of that period are assigned a ‘cruise’ number, and information relating to that cruise is stored in the Cruise table. Information relating to sampling events conducted at individual stations during a cruise (e.g., station depth, weather) will be stored in the Event table. Water quality parameter values will be stored in the Data table. Concentrations of chlorophyll, the photosynthetic pigment(s) in phytoplankton, are obtained by several different methods, each of which has intermediate measurements (of optical density) that feed equations yielding concentration estimates. The intermediate measurements are contained in the Chlorophyll table and the chlorophyll concentration value is stored in the Data table. Similarly, the measure of light attenuation KD is obtained from several intermediate factors and these intermediate values are stored in the KD table, while the value of KD itself is found in the Data table. Quality assurance data are a special breed of data and they are stored in the QAQC table. The first step of the online data retrieval process, the selection of *Data Type* described above, gives a hint of this behind-the-scenes database structure.

Related to these tables are ‘look-up’ tables that list allowable, defined entries for coded variables in the primary tables.

Cruise numbers are assigned at the beginning of the year and the cruise schedule, including past and future cruises, are available in the water quality *Documentation* menu: [Water Quality Monitoring Cruise Schedules](#).

### **Downloaded files**

Tables 1 through 5 are examples of files created from the five different Data Type selections:

- Station Information (Table 1),
- Monitoring Event Data (Table 2),
- Water Quality Data (Table 3),

- Light Attenuation Data (Table 4), and
- Optical Density Data (Table 5) for chlorophyll and other photosynthetic pigments.

The most common data retrieval and the one focused on in this section is for Water Quality Data (Table 3). This basic retrieval is parameter-focused and primarily populated from the WQ\_DATA relational data table with some additional information from others. The table shows hypothetical data records for two parameters measured in-situ in the field: water temperature (WTEMP) and Secchi depth (SECCHI), and two parameters measured in water samples sent to the laboratory: total dissolved nitrogen (TDN) and total suspended solids (TSS). The file has a ‘vertical’ data structure (data in column format), in contrast to the ‘horizontal’ structure (data in rows) of the data storage and analysis software (SAS) used in the early years of the Program.

### **Primary variables**

As shown in Table 3, the variable PARAMETER contains the name of the water quality field or laboratory parameter being reported; the variable REPORTED\_VALUE contains the measurement (e.g., concentration, meter reading). Each value is uniquely identified in time and space by a number of associated variables. Refer to the relevant sections in the [Water Quality Database Design and Data Dictionary](#) for valid codes and values for the variables and their definitions. More details about individual variables are given in Section IV.

### **Identifier variables**

- STATION provides the location name. Be aware that a station may be sampled in more than one project or program and by multiple agencies. Parameters and analytical methods, as well as the objectives of data collection may differ. Depending on application, therefore, it may be useful or even critical to identify data by such ‘corollary’ variables as PROJECT, PROGRAM, SOURCE and/or AGENCY. See also Appendices 1 and 2.
- LATITUDE and LONGITUDE provide universally recognized geographic coordinate information (UTM X- and Y-coordinates are available in the WQ\_STATION table.)
- DEPTH identifies vertical distance from the surface. Some parameters, such as measurements of water clarity, are not intrinsically associated with a specific water depth, but are commonly analyzed in association with other water quality parameters that are. For convenience sake, in the CIMS database, such parameters are assigned to the surface depth and layer. In some cases, those parameters are assigned depth=0, while the depth-specific measurements are assigned to the actual sampled depth (> 0); in other cases, such parameters are assigned to the same depth as the surface measured parameters.
- LAYER is a coded variable that identifies location in the water column in terms of stratum. In the CBP Monitoring Program, layers are defined relative to a vertical density gradient, or pycnocline. For reasons that are explained elsewhere, a particular layer (usually surface) can have more than one depth association (e.g., depth=0 and depth=0.5 m) and a particular depth may represent more than one LAYER at the same time, thus both depth and layer variables may be required to uniquely identify a particular data point.
- SAMPLE\_DATE and SAMPLE\_TIME variables indicate when the water sample or measurement was collected. Although the actual elapsed time to collect water samples and in-situ measurements at a station may be considerable, all parameter values collected at a single sampling event at a station are assigned the same SAMPLE\_TIME in the CBP Mainstem and Tributary Water Quality Monitoring Program data sets. Note that this is not always true in the

Light Attenuation data sets and may not be true of all programs in the CIMS Water Quality Database.

- SAMPLE\_REPLICATE\_TYPE is a coded variable that indicates whether the sample is a laboratory replicate and/or a field split. There is inconsistency among labs in whether the individual replicate values or their means are present in the data.

See Section IV for more discussion of these variables.

### **Corollary variables**

Each PARAMETER has other associated variables that provide additional information about the data point:

- QUALIFIER is a coded variable that indicates whether a value is above or below (> or <) the limit of analytical detection.
- UNIT is the abbreviation for the parameter value's units of measure.
- SAMPLE\_TYPE is a coded variable that indicates the type of sample collected, e.g., Discrete (D), Composite (C), In-Situ Measurement (ISM).
- LAB is the abbreviation for the facility performing the water sample analysis.
- METHOD is a coded variable that identifies the particular field or laboratory method.
- PROBLEM is a coded variable that flags and identifies analytical problems, if any. Anomalies may also be further explained in the DETAILS field.
- DETAILS are comments relating to the parameter value.
- TOTAL\_DEPTH is the total depth at the station where the sample value was collected.
- UPPER/LOWER PYCNOCLINE. These give the upper- and lower-most depths where a pycnocline (density discontinuity) is detected.
- SOURCE/PROJECT indicate more about the source and context of the data and these variables may need to be included with other Identifier Variables for stations sampled in multiple programs and/or by multiple agencies and if that fact is relevant to the user's application.

Other variables are available which provide additional information or which are useful for aggregating or isolating groups of data:

- EVENT is a unique number that identifies and ties together all information that relates to samples and measurements collected at a station at a particular time;
- Weather and sea-state conditions at the time of sample collection are examples of corollary information relating to a sampling EVENT.
- CBSEG\_2003 (monitoring segment), BASIN, WATER\_BODY, UTM-X and UTM-Y (geographic coordinates) are examples, among many others, of descriptive variables relating to the sampling STATION.

At present, these and other associated variables are accessed by performing separate data retrievals using appropriate *Data Type* or *Attribute* selections and then merging the information using key relational variables. Tables 1 through 5 provide the Data Type retrievals that can be obtained and how the data can be related to each other using these variables. Also, refer to the relevant sections in [Water Quality Database Design and Data Dictionary](#) for additional information about the contents of the various data tables.

#### **IV. ABOUT THE VARIABLES AND PARAMETERS**

The summary information about each parameter measured or calculated is intended to make general users and data analysts aware of special problems they may encounter when using the data. These include method changes, problems with inter-organization agreement, and relevant Data Analysis Issues Tracking System ([DAITS](#)) issues. A table of DAITS issue titles is in Appendix 4.

The many variable and parameter names sanctioned in the CBP Water Quality Database are succinctly defined in the [Water Quality Data Dictionary](#). Assembly of this water quality database began in the early 1980s and there has been a revolution in data management technology and consequently an evolution of the database. One aspect of change is that the length of variable names is no longer limited to 8 characters and many old names have been changed to be more informative. Since many documents and applications exist that use the old naming convention, both old and new variable and parameter names are shown in the summaries.

The summaries that follow are organized by data category. First are the observation identifier variables, then field parameters, then the water quality/water chemistry parameters. There is inconsistency among the parameters in the extent to which the parameter information has been updated.

**TITLE:** CBP SEGMENT DESIGNATION  
**PARAMETER NAME (NEW):** CBSEG\_2003  
**PARAMETER NAME (OLD):** SEGMENT  
**UNITS OF MEASURE:** None  
**METHOD CODES:** None

**GENERAL INFORMATION:**

The Chesapeake Bay segments are geographical units used in the analysis of water quality data. They are based on circulation and salinity properties of different areas of the Bay. The original scheme was developed as part of the seminal assessment of the Bay ("Chesapeake Bay: A profile of environmental change", CBP 1983). For a number of reasons, the segmentation scheme was revised in the 1990s and further modified in 2003. The segment variable now carries its version identification in its variable name. A segment [map](#) and detailed description and history of the [segmentation schemes](#) are available at the Data Hub.

In the original segmentation scheme, the segment naming convention was as follows:

- CBx indicated that the segment was in the Chesapeake Bay proper
- LEx indicated *lower estuarine* zone in the major (western shore) tributaries;
- RETx indicated *riverine-estuarine transition* zone in the (western shore) tributaries;
- TFx indicated *tidal fresh* zone in the major (western shore) tributaries
- EEx indicated an *Eastern Shore embayment*
- WTx indicated a minor *western tributary*
- ETx indicated a minor *Eastern Shore tributary*

When the segmentation scheme was re-examined, the segment naming convention was changed along with a number of boundary definitions. The segment names now relate to the actual name of the water body and salinity zone: TF=tidal fresh, OH=oligohaline, MH=mesohaline, and PH=polyhaline. For example, the lower Potomac River segment was 'LE2' and is now 'POTMH'.

**DAITS ISSUES:**

None

**OTHER ISSUES:**

In the 2003 revision, segment boundaries were drawn more precisely according to a salinity-based protocol a small number of segments without any monitoring sites were created in the process: CHSTF in the Chester River, CHOTF in the Choptank, HNGMH in the Honga, NANOH in the Nanticoke, and POCOH in the Pocomoke River. LYNPH was created for the Lynnhaven Inlet because of SAV survey information. These 'empty' segments can cause confusion when comparing data products from station-based observations and products such as come from the CBP Interpolator or water quality model which may provide estimates for these segments from extrapolated data.

At the inception of the CBP Monitoring Program, the naming convention for monitoring stations used the segment name as prefix, plus a sequence number with other stations in the segment. For example, Station LE2.3 is one of several stations in the lower Potomac River segment



formerly known as LE2 and now as POTMH. Although the segment names changed in the revision process, the names of the stations did not. It was felt that the cost of confusion caused by stations having multiple historical identities outweighed the benefits. For most stations, there is now no connection between their name and the segment that contains them.

Other segmentation schemes have been developed for special applications such as the submerged Aquatic Vegetation (SAV) aerial survey, the 3D model segments, and the Watershed Model [segments](#).

#### OTHER DOCUMENTATION:

CBP 1983a, "Chesapeake Bay: A profile of environmental change," for descriptions of each segment. Appendix A, Section 2, has the most complete description.

CBP 1990, "The Chesapeake Bay Segmentation Scheme," for geographic boundaries of the segments.

CBP 2005, "Chesapeake Bay Program Analytical Segmentation Scheme; Revisions, Decisions and Rationales 1983-2003." [2005 Addendum](#).

<b>TITLE:</b>	<b>CRUISE IDENTIFIER</b>
<b>PARAMETER NAME (NEW):</b>	<b>CRUISE</b>
<b>PARAMETER NAME (OLD):</b>	<b>CRUISE</b>
<b>UNITS OF MEASURE:</b>	<b>None</b>
<b>METHOD CODES:</b>	<b>None</b>

#### GENERAL INFORMATION:

CRUISE is a variable used to identify observations that together provide a synoptic view—a ‘snap shot’—of conditions in a water body at one time. In the main stem Bay, for example, it usually takes multiple days to sample all the stations, and the CRUISE number is useful for grouping the data collected over that narrow range of dates. Cruises are numbered sequentially and begin with the letters "BAY," e.g. "BAY001" (June 1984), indicating that the cruise referencing is to the main stem Bay, even if the sampling event is in a tributary. The cruise schedule is available online at the Data Hub under *Documentation: Water Quality Monitoring Cruise Schedule* [[link](#)] by sampling year.

Cruise numbers are assigned in advance and published with the cruise schedule at the beginning of the year. In months when two mainstem cruises might be scheduled, March through October, the first cruise is typically planned between the 1st and 15th of the month, and the second cruise between the 16th and the last day of the month. In months when only one cruise is planned, the cruise may be scheduled at any time during the month. Be aware, however, that scheduled cruise dates can be altered due to weather conditions.

Cruises can extend over 3-4 days or longer. The several collecting institutions attempt to sample over the same time period and to visit stations in the same order at approximately the same time of day on each cruise. Deviations from this schedule exist, however. In extreme cases, the sampling dates of the several collecting institutions for the same 'cruise' can be separated by more than a week. In general, with respect to order and time of day, upper Bay stations have been sampled most consistently. Lower Bay stations have been sampled least consistently primarily because of time constraints, distance between stations and weather.

A cruise number is attached to both mainstem and tributary monitoring cruises, with the purpose of enabling a user to identify the best synoptic ‘snapshot’ of the Chesapeake’s estuarine waters. This is particularly important for the CBP Interpolator (Data Hub *Data Tools* and Appendix 5) and other models that use ‘point’ parameter measurements from the monitoring stations to map and estimate conditions at intermediate locations throughout the basin. Because of inadvertent deviations from the planned cruise schedule, proper cruise number assignments require a second look, after all the sampling events basin wide have been completed for the month. This is best done by the CBP Water Quality Data Manager who has first access to the cruise information from all the participating data collection institutions. Data collection in the mainstem is generally more easily coordinated among agencies than in the widespread tributaries. In addition, many tributary stations are sampled once per month while main stem stations may be sampled more frequently depending on the month of the year. The user is warned to review the cruise assignments and sampling dates if synchronous sampling is important to the desired application.

METHOD CHANGES:

None

DAITS ISSUES:

None

OTHER ISSUES:

On rare occasions, cruises that begin in one month are delayed and continued into the next month. Because many analyses aggregate data by month or by seasons defined by month, some data from such cruises may be not be associated with the desired month if the cruise variable is not used and data partitioning is based on month derived from date alone. Below is a list of such occasions through 2005.

<b>CRUISE</b>	<b>YEAR</b>	<b>ACTUAL MONTH</b>	<b>CRUISE MONTH</b>
BAY027	1985	10	9
BAY029	1985	11	10
BAY119	1990	6	5
BAY123	1990	8	7
BAY155	1992	4	3
BAY232	1996	2	1
BAY263	1997	8	7
BAY312	2000	2	1
BAY319	2000	6	5
BAY343	2001	8	7
BAY357	2002	5	4
BAY365*	2002	9*	8
BAY369	2002	11	10

\*lower bay neighboring stations sampled >10 days apart.

There may be gaps in the cruise sequence for individual stations and/or agencies. These may be due to several reasons: stations are sampled only during certain seasons; cruise(s) dropped by one agency, but not by others; a cruise was cancelled because of weather.

In the tributary data sets, CRUISE contains the value most closely related temporally to a mainstem cruise and also begins with the letters "BAY." Since tributary and mainstem sampling dates often vary by more than a week, the user should remember that combining these data sets by CRUISE number will not necessarily produce the same synoptic view as one would expect when using bay-wide data sets for the same CRUISE.

OTHER DOCUMENTATION:

None



**TITLE:** **DATE OF SAMPLE COLLECTION**  
**PARAMETER NAME (NEW):** **EVENT\_START\_DATE**  
**PARAMETER NAME (OLD):** **DATE**  
**UNITS OF MEASURE:** **None**  
**METHOD CODES:** **None**

**GENERAL METHOD:**

EVENT\_START\_DATE is the date of sample collection. The value of this variable officially resides in the EVENT table, but is added to a downloadable data table as SAMPLE\_DATE.

**METHOD CHANGES:**

None

**DAITS ISSUES:**

None

**OTHER ISSUES:**

SAMPLE\_DATE is a "key" sorting field when searching for a particular observation in the database.

The user may also want to keep the CRUISE variable as a second time period identifier. Monitoring cruises are scheduled to represent a particular month and to characterize seasonal conditions. On a few occasions, cruises have extended past the end of the month and some stations in that cruise are sampled in the next month. In those instances, the user will be misled by using SAMPLE\_DATE alone to identify the month or season that the samples were intended to represent.

**OTHER DOCUMENTATION:**

None

<b>TITLE:</b>	<b>SAMPLE LAYER</b>
<b>PARAMETER NAME (NEW):</b>	<b>LAYER</b>
<b>PARAMETER NAME (OLD):</b>	<b>LAYER</b>
<b>UNITS OF MEASURE:</b>	<b>None</b>
<b>METHOD CODES:</b>	<b>None</b>

**GENERAL METHOD:**

The CBP Monitoring Program sampling design takes into account the potential for strong differences in water quality between surface and bottom in Chesapeake Bay waters. For the most part, these differences are the result of density differences between the fresh water coming in from the tributary headwaters and the salty ocean water entering the system at the Bay mouth. At times and places the water column may be well mixed. When the water column is stratified, however, differences between top and bottom can be extreme. The region of density discontinuity separating the top and bottom layers is called the region of the pycnocline.

To represent these different water masses, samples for water chemistry analyses are collected at surface and bottom and, at stations with a stratified water column, at two mid-water depths based on the presence and location of the pycnocline (see "Pycnocline, Upper and Lower Depths" for a definition). LAYER codes identify these samples: S=surface, AP=above the pycnocline, BP=below the pycnocline, and B=bottom. If no pycnocline is present, samples are collected at 1/3 and 2/3 of the total depth and LAYER is coded as AP and BP respectively. The variables PYCNOCLINE\_UPPER and LOWER are blank or missing in this case.

Physical/chemical profiling of the water column is done at generally regular depth intervals, usually 1 to 2 meters apart. Where these measurements are taken and there is no water chemistry sample collected at the same depth, the LAYER code = 'M' for mid-depth and is unrelated to pycnocline depth. .

Maryland: On the Program's first mainstem cruise, 4 grab samples were collected at each station. Thereafter, shallow stations were sampled only at surface and bottom layers. Elsewhere, where a pycnocline exists, the above pycnocline sample is collected 1-1.5 meters above the pycnocline, the below pycnocline sample is collected 1-1.5 meters below the pycnocline, and the bottom sample is collected 1-1.5 meters from the bottom. Where both an upper and lower pycnocline exist, then the above pycnocline sample is collected above the upper pycnocline and the below pycnocline sample is collected below the lower pycnocline. No sample is collected from the intermediate zone. As mentioned above, if no pycnocline exists, then samples are collected at surface and bottom layers, and at 1/3 and 2/3 total depth.

The State of Maryland's Core-Trend sampling program has a number of stations in common with the CBP Monitoring Program (see Appendix 1). The Core-Trend program collects data for a number of the same parameters, but at fixed depths. Data from these 'extra' samples are included in the data submission, but all data, including nutrient and other water chemistry data, that are not shared by both programs are coded as LAYER='M'.

Virginia (VIMS and ODU): Specific stations are identified as "pycnocline" stations and surface, above pycnocline, below pycnocline, and bottom water chemistry samples are collected only at

these stations. At non-pycnocline stations, water chemistry samples are collected only from the surface and bottom layers. There is no indication of pycnocline presence (upper and lower pycnocline depths are missing). On the early cruises, ODU did not look for or identify a lower pycnocline at any station. Beginning with CRUISE BAY113, both upper and lower pycnocline depths are always coded.

#### METHOD CHANGES:

Maryland: In the first years of the program, water chemistry samples were collected from whatever depth was indicated by the pycnocline computation, regardless of whether physical/chemical measurements had been collected at that depth. Starting in 1985, the sampling protocol was changed so that water chemistry samples are always associated with profile measurements.

Virginia: Above pycnocline and below pycnocline samples were not necessarily collected relative to the pycnocline depth as defined by CBP methods (see "Pycnocline, Lower Depth," below). Also, early VIMS data did not include layer codes, and these were assigned by CBP computer center staff using the upper pycnocline depth. In early VIMS data, therefore, there may be more than one sample per layer code for a given station and date (albeit at different depths); i.e., two above pycnocline samples and no below pycnocline sample, or two below pycnocline samples and no bottom sample. The variable DEPTH must be included to sort these records correctly (refer to DAITS #25).

#### DAITS ISSUES:

#025 – There are differences in the way in which the various collecting agencies determine upper and lower pycnocline depths. The determination of these depths affects the depth at which AP and BP will be sampled.

#### OTHER ISSUES:

##### Samples at the same depth with different LAYER codes:

Depending on the stratification characteristics of the water column, S and AP, or B and BP samples (each collected separately) can occur at the same sampling depth. This occurs mostly in the Maryland portion of the Bay and at Virginia stations CB6.4, CB7.3, and CB7.4. Merging records by depth alone can result in the loss of information for one of the co-located layers. LAYER, therefore, is a 'key' identifier variable. To sort records, sort by STATION, SAMPLE\_DATE, DEPTH, LAYER and SAMPLE\_ID ('replicate' number).

##### LAYER as locator for nutrient values:

The above discussion should suggest to the user that the primary value of the LAYER variable is to locate water chemistry data in the database efficiently and to associate those data properly relative to a pycnocline. LAYER can not be used reliably as an indicator of the presence or absence of a pycnocline. The user must examine the conductivity profile in the database to confirm the presence or absence of a pycnocline. This topic is discussed further under PCYNOCLINE\_UPPER AND \_LOWER.

##### Change in the method of calculating pycnocline depth:

The field definition of pycnocline and the calculation of LAYER boundaries have come under scrutiny with the advent of water quality criteria and criteria assessment. At present, the method of calculating upper and lower pycnocline depths used in the water quality monitoring program to define LAYERS and to determine where water quality measurements are taken differs significantly from the method used in water quality criteria to define 'designated use' regions. Exploratory exercises comparing pycnocline depths derived from the two methods with respect to physical/chemical distributions in the water column have been inconclusive, and consequences for the Program of this inconsistency have not been fully explored. This topic is also discussed further under PCYNOCLINE\_UPPER AND LOWER.



**TITLE:** PYCNOCLINE, UPPER AND LOWER DEPTHS  
**PARAMETER NAME (NEW):** UPPER\_, LOWER\_PYCNOCLINE  
**PARAMETER NAME (OLD):** PDEPTHU, PDEPTHL  
**UNITS OF MEASURE:** Meters  
**METHOD CODES:** None

**GENERAL METHOD:**

See text above for SAMPLE LAYER for a description of vertical stratification, or layering, which occurs in estuaries due to density differences of mixing water masses. In the CBP Monitoring Program, layer boundaries are defined relative to the boundaries of a pycnocline, if one exists. The "pycnocline" is the region of the water column where density is changing rapidly due to salinity and temperature differences, and the top and bottom depths of the pycnocline region are identified in the CBP database by the variables UPPER\_ and LOWER\_PYCNOCLINE.

The presence and location of a pycnocline is determined from the conductivity profile. A computed threshold value (CTV) is calculated from 2 times the mean change in conductivity per meter between the surface and bottom. If the CTV exceeds 500 micromhos/cm per meter, a pycnocline is said to exist. The UPPER\_PYCNOCLINE depth is defined as the first depth interval from the surface with a change in conductivity that exceeds the CTV. The above pycnocline layer is thus bounded above by the water surface and below by the upper pycnocline. The boundaries of the lower layer depend on the complexity of the vertical structure. The lower boundary of the lower layer is the bottom substrate. The upper boundary of the lower layer is defined at the first depth interval from the bottom with a change in conductivity that exceeds the CTV. If density differences are gradual, the upper boundary may be the upper pycnocline. If a density difference exceeding the CTV is encountered which is below the upper pycnocline, then a LOWER\_PYCNOCLINE is said to exist and this becomes the upper boundary of the lower layer. The region between the upper and lower pycnocline boundaries may be small to nonexistent or at times substantial, but nutrient samples are not collected from this region of rapid change. See below for details of the method used by each collecting organization.

Where a pycnocline exists, the above pycnocline (AP) sample is usually collected 1.5 meters above the UPPER\_PYCNOCLINE depth, and the below pycnocline (BP) sample is usually collected 1.5 meters below the LOWER\_PYCNOCLINE depth.

MD/MDE: MDE averages the two sample depths in which the difference in conductivity exceeds the computed threshold value (CTV). For UPPER\_PYCNOCLINE, these values are the first pair from the surface and for lower pycnocline, the first pair from the bottom that exceed the CTV.

VA/ODU: ODU assigns the UPPER\_PYCNOCLINE value to the shallower of the two sample depths that exceed the CTV (not the average). ODU sets the LOWER\_PYCNOCLINE value similar to MDE, except the value is the deeper of the two sample depths.

VA/VIMS: VIMS assigns the value of UPPER\_PYCNOCLINE to the shallower of the two sample depths that exceed the CTV (not the average). Because they use a different method to

define the pycnocline, in VIMS data, LOWER\_PYCNOCLINE is equal to UPPER\_PYCNOCLINE.

#### METHOD CHANGES:

Refer to "Identifier Variables - LAYER."

#### DAITS ISSUES:

#025 – There are differences in the way in which the various collecting agencies determine UPPER\_PYCNOCLINE (PDEPTHU) and LOWER\_PYCNOCLINE (PDEPTHL). The determination of these depths affects the depth at which AP and BP will be sampled.

#040 – Different methods for determining pycnocline depth are used for WQ field sample collections and for Bay Program criteria-related Designated-Use boundary delineations. The pycnocline depth in the monitoring database is based on density calculations derived from conductivity measurements and on the algorithm described above. For defining Designated Use boundaries, pycnocline depth is based on density calculations derived from salinity and temperature measurements. For the same sampling event, pycnocline depths based on these different methods often differ.

#### OTHER ISSUES:

Refer to "Identifier Variables - LAYER."

If a pycnocline was determined not to exist and sampling occurred at 1/3 and 2/3 of total depth, then UPPER\_PYCNOCLINE and LOWER\_PYCNOCLINE depths are set to missing in the database. The LAYER parameter is coded AP and BP, to facilitate data retrieval by layer.

In the mainstem waters of Virginia, there are specified 'pycnocline stations', i.e., particular stations whose vertical structure is examined for the presence of a pycnocline and 4 samples are collected as described above. At non-pycnocline stations, the presence of a pycnocline is not looked for and only surface and bottom samples are collected regardless of vertical density structure. Users who are interested in accurately assessing vertical density structure should not assume that missing values for upper and lower pycnocline depth mean that no pycnocline was present.

In May 2008, ODU changed their pycnocline calculation to be consistent with MDDNR. Depth is now calculated by subtracting the surface sample depth (1.0 meter) from the depth at which the bottom sample was collected. Previously, the station total depth was used.

#### OTHER DOCUMENTATION:

See "Identifier Variables - DEPTH and LAYER," Chapter V, "Related Documentation," and the "Data Management Plan" (CBP 1992a).

**TITLE:** **REPLICATE NUMBER**  
**PARAMETER NAME (NEW):** **SAMPLE\_REPLICATE\_TYPE**  
**PARAMETER NAME (OLD):** **REP\_NUM**  
**UNITS OF MEASURE:** **None**  
**METHOD CODES:** **None**

**GENERAL METHOD:**

SAMPLE\_REPLICATE\_TYPE in monitoring data sets represents the field replicate number. These may represent field splits from a single sample (MDE and VIMS) or true field replicates (two successive grab samples, ODU).

MD/MDE: Ten percent of water samples collected in the field are split for duplicate analysis (the whole suite of laboratory analyses are duplicated). Specific stations and layers with field replicates are: CB1.1-B, CB2.2-S, CB3.3C - B, CB4.1W - S, CB4.2E - B, CB4.3C - AP, CB4.4 - B, and CB5.2 - S. See DAITS #3 for more details. Both split sample results are reported in the regular monitoring database (SAMPLE\_REPLICATE\_TYPE=S1 or S2).

VA/ODU: Field replicates from station CB7.3 or CB7.4N, collected as two successive grab samples, have been submitted since June 1984 and are coded in regular monitoring data as SAMPLE\_REPLICATE\_TYPE=S1 or S2.

VA/VIMS: The means of two field splits, but not the two separate values, are included in the monitoring database beginning with Cruise 96 (the first cruise in April 1989). Thus, the variable SAMPLE\_REPLICATE\_TYPE is always set to FS\_AVG in VIMS mainstem monitoring data for the period 1989 through 1995. For tributary and shallow water monitoring data collected from 2001 to present, the codes S1 or S2 are used.

**METHOD CHANGES:**

None

**DAITS ISSUES:**

#003 – See this issue for more details on field replicate methods.

**OTHER ISSUES:**

None

**OTHER DOCUMENTATION:**

None

**TITLE:** **SAMPLE DEPTH**  
**PARAMETER NAME (NEW):** **DEPTH**  
**PARAMETER NAME (OLD):** **SDEPTH**  
**UNITS OF MEASURE:** **Meters**  
**METHOD CODES:** **None**

**GENERAL METHOD:**

MD/MDE: At the beginning of the program (June 1984 through April 1986), physical/chemical profiles were collected at every meter, beginning with 0.5 meter, and continuing until there was little change in temperature, salinity, or dissolved oxygen. Thereafter physical/chemical measurements were collected every 3 meters to the bottom.

VA/ODU: ODU takes profile samples at 1-meter intervals, beginning with 1 meter up to 15 meters and then every 2 meters to the bottom.

VA/VIMS: During the first cruise, June 1984, the physical/ chemical profile began at 2 meters and measurements were collected every 2 meters to the bottom.

**METHOD CHANGES:**

MD/MDE: The protocol was modified in May 1986 and measurements were recorded at 0.5, 1, and 3 meters (2 meter measurement added in 2003) and thereafter at 2-meter intervals. If dissolved oxygen concentration changed more than 1 mg/l over the interval, or conductivity changed more than 1000 umhos/cm, then readings were taken at 1-meter intervals.

VA/VIMS: From July 1984-July 1986, the surface layer sample was at 1 meter and successive samples were taken at 2-meter intervals. From August 1986-June 14, 1987, the surface was at 1 meter, samples were taken every 1 meter down to 15 meters, and every 2 meters below that. Starting June 15, 1987, a profiling CTD took readings for all parameters except DO every meter from 1 meter depth to the bottom; the protocol for DO did not change, since VIMS staff measure DO with a YSI meter.

DAITS ISSUES: None

**OTHER ISSUES:**

DEPTH = 0 in the database header record is reserved for station information such as Secchi depth readings, tide stage, weather, air temperature, etc., at the time the station is sampled.

**OTHER DOCUMENTATION:**

None

**TITLE:** TOTAL DEPTH  
**PARAMETER NAME (NEW):** TOTAL\_DEPTH  
**PARAMETER NAME (OLD):** TDEPTH  
**UNITS OF MEASURE:** Meters  
**METHOD CODES:** None

**GENERAL METHOD:**

Total Depth represents the measured water depth at the station. It should be greater than any sample depths, since the "bottom" sample is always taken slightly above the actual bottom. TOTAL\_DEPTH will vary slightly at the same station over time because of changes in tidal stage and exact sampling location. The total depth measurement may be done in several ways: from the vessel depth finder, the pressure sensor of the sonde, or calibrated markings on lines attached to the sampling equipment.

**METHOD CHANGES:**

The method of determining station depth may vary within and between sample collection organizations. Research vessels, large and small, have depth sensing instruments of various manufactures. Smaller boats used in the tributaries may rely on hand-held lines and calibrated sampling hoses to determine station depth.

**DAITS ISSUES:**

#039 – Variability in station depth. Some stations show relatively large differences in total depth from cruise to cruise and over time. There are a number of reasons for this: 1) station has changed location over time, 2) station is in a region of rapid change in depth, e.g., near a hole or along edge of the ship channel, where small differences in the ship's orientation result in large differences in total depth measurements; 3) actual large differences in water depth at these locations under some circumstances.

**OTHER ISSUES:**

None

**OTHER DOCUMENTATION:**

None

**TITLE:** **SAMPLING STATION IDENTIFIER**  
**PARAMETER NAME (NEW):** **STATION**  
**PARAMETER NAME (OLD):** **STATION**  
**UNITS OF MEASURE:** **None**  
**METHOD CODES:** **None**

**GENERAL METHOD:**

All of the mainstem data submitters locate their stations using GPS. MDE holds the station by anchor if required by weather or currents, VIMS holds the station by anchor, and ODU positions the vessel to drift through the station area.

**METHOD CHANGES:**

None

**DAITS ISSUES:**

None

**OTHER ISSUES:**

The submitter's station name is not kept in the database. If needed, the user should refer to the "Chesapeake Bay Basin Monitoring Program Atlas" (CBP 1989) for lists of the submitter's station names.

The shallow stations in the uppermost part of the Bay (Stations CB1.1 and CB2.1) may be ice-covered during some part of the winter. Data gaps are common during those months.

As a cost-saving measure, beginning in fall 1988, the lateral stations in the MD portion of the Bay (CB3.3E, CB3.3W, CB4.1E, CB4.1W, CB4.2E, CB4.2W, CB4.3E, and CB4.3W) are not sampled from November through the first cruise in March.

To monitor the effect of dumping dredge spoil in the deep trench, the Maryland Port Authority funded an additional transect of stations (CB4.0E, CB4.0C, and CB4.0W) within the Monitoring Program sampling design. These stations were sampled from June through September 1990. CB4.0C is the only station where nutrient samples were collected.

VIMS and MDE both sampled CB5.3 until April 1990. Due to the frequency of sampling variations, this was discontinued and VIMS no longer sampled this station. To avoid confusion caused by having the same station duplicated, the VIMS data were removed from the database, but is available upon request.

**OTHER DOCUMENTATION:**

None.

**TITLE:** SOURCE AGENCY  
**VARIABLE NAME (NEW):** SOURCE  
**VARIABLE NAME (OLD):** SOURCE  
**UNITS OF MEASURE:** None  
**METHOD CODES:** None

**GENERAL METHOD:**

The full updated list of valid codes for SOURCE is maintained online in the Data Dictionary. Current CBP Monitoring Program SOURCE codes include "MDDNR", "ODU", "VIMS", "USGS", "SRBC", "VADEQ/NRO", "VADEQ/PRO", and "VADEQ/TRO".

**METHOD CHANGES:**

None

**DAITS ISSUES:**

None

**OTHER ISSUES:**

SOURCE usually identifies the field sampling organization. It does not necessarily identify the analytical laboratories. In Maryland, Central Regional Laboratory (CRL), Chesapeake Biological Laboratory (CBL), and Maryland Department of Health and Mental Hygiene (MDHMH) all have the same source. In Virginia tidal tributaries, SOURCE distinguishes the several regional offices of the VA Department of Environmental Quality: Northern (NRO), Piedmont (PRO) and Tidewater (TRO) Regional Office.

**OTHER DOCUMENTATION:**

None

**TITLE:** **SAMPLING START TIME**  
**VARIABLE NAME (NEW):** **EVENT\_START\_DATE\_TIME**  
**VARIABLE NAME (OLD):** **TIME**  
**UNITS OF MEASURE:** **MM/DD/YYYY HH:MM:SS AM/PM**  
**METHOD CODES:** **None**

**GENERAL METHOD:**

The variable EVENT\_START\_DATE\_TIME is the concatenation of the SAMPLE\_DATE and SAMPLE\_TIME fields submitted by the data providers. In the CIMS database, it is a Date/Time formatted variable.

**METHOD CHANGES:**

None

**DAITS ISSUES:**

None

**OTHER ISSUES:**

None

**OTHER DOCUMENTATION:**

None



**TITLE: PHYSICAL PROFILE SAMPLING METHODS**

**PARAMETER NAME:** See individual parameter descriptions

**GENERAL METHOD:**

A vertical profile of *in-situ* physical parameters is determined at each sampling station. Water temperature, pH, dissolved oxygen (DO), salinity, and associated depth are measured at various intervals from the bottom to the surface of the water column. The depth of each measurement and total depth are also measured. Underwater, multi-parameter instruments such as YSI or Hydrolab® sondes are typically used. A sonde is outfitted with a data logger or computer to display, record and in some cases, store the measurements.

ODU: From May 1986 to February 1997 a Hydrolab® Surveyor II sonde attached to a sampling pump was used. The sonde was lowered in discrete increments with depth being determined from the depth sensor on the sensor, and the suite of readings copied by hand to field sheets. From March 1997 through March 2008, ODU used a YSI 6000 Sonde, and currently uses a YSI 6600 V2 Sonde, equipped with an optical DO sensor and a YSI 650 DM Data Logger.

MDDNR: Mainstem and Patuxent River cruises use YSI Series 6 (including recently added Series 6820) instruments. All other sampling activities use Hydrolab® (Series 4000 and 2, Series 3, 4a, and 5) or YSI Series 6 instruments. In February 2009, YSI Series 6820 sondes equipped with optical DO sensors were added to the line. All sondes are attached to data loggers and readings are copied by hand to field sheets.

VADEQ: Hydrolab® sensors have been utilized for the tidal program almost exclusively since its inception in 1984. Surveyor II sensors were utilized initially and Hydrolab® Series 3 (H2O) sensors were purchased in 1993. Additional Series 4, 4a and 5 DataSondes have been purchased and utilized until October 2010. In October 2010, regional field offices began using DO optical sensors with the exception of VADEQ/PRO which continues to utilize Hydrolab® sondes with Clark-cell sensors.

VIMS: VIMS used a CTD for conductivity and water temperature and an YSI meter for dissolved oxygen. The CTD and YSI assembly is lowered at a constant rate and both are attached to the sampling pump. ODU assumed responsibility the sampling in January 1996.

**METHOD CHANGES:**

Initially, ODU used an YSI oxygen meter in conjunction with a RS-5 salinometer (June 1984 to April 1986) and depth was determined from meter markings on the cable.

Originally, MDE and ODU lowered the multi-parameter sondes separately from the sample collection pump. MDE started attaching the Hydrolab® sensor to the submersible sampling pump and lowering them together on 1/1/89, and ODU made this change on 8/21/91. In July 2003, ODU collects discrete water samples using rosette bottles instead of a submersible pump.

VIMS used an Interocceans CTU early in the program and later, Applied Microsystems CTD, They always used a YSI meter for dissolved oxygen.

DAITS ISSUES:

None

OTHER ISSUES:

None

OTHER DOCUMENTATION:

None

**TITLE:** DISSOLVED OXYGEN  
**PARAMETER NAME (NEW):** DO  
**PARAMETER NAME (OLD):** DISOXY  
**UNITS OF MEASURE:** mg/l  
**METHOD CODES:** See Methods Table

**GENERAL METHOD:**

Dissolved oxygen (DO) is measured *in-situ* at each station. DO sensors are calibrated at the beginning and end of each multiple-day cruise according to manufacturer's specifications. Calibration checks are done at the beginning of each sampling day.

MDDNR: MDNR validates DO measurements by performing daily calibration checks. Clark-cell sensors are calibrated in water saturated air and optical DO sensors are calibrated using air-saturated water. In the past Winkler calibration checks were recorded on the field sheets but never submitted to the CBPO as separate parameters. Calibration checks now are done at the beginning of each day and must be within 0.3 mg/L of the expected value.

ODU: From 1984 to 2007, ODU submitted two dissolved oxygen variables, DISOXY and DISOX2, with the water quality data. The variable DISOXY contains the sonde measurement. The variable DISOX2 contains the Winkler titrated value. DISOXY values are maintained in both levels of the database, and DISOX2 is available upon request. Currently, ODU reports DISOXY as DO.

VADEQ: Beginning in October 1998, one Winkler DO titration was done both in the morning and afternoon to check the DO sensor. In January 2008, Winkler DO samples were no longer collected. Currently, VADEQ reports DISOXY as DO.

**METHOD CHANGES:**

ODU: Instrument changes are documented in the Physical Profiling Sampling Methods section (page 43). In January 2008, ODU discontinued Winkler DO check samples; the air calibration check performed each morning is sufficient. ODU switched to an optical sensor in April 2008.

**DAITS ISSUES:**

DAITS #047 – Comparability of in-situ DO measurements using Clark-cell (polarographic) sensors vs. Luminescent Optical DO sensors. The report is incomplete but a draft is available upon request. In 2007-2008, Chesapeake Bay tidal monitoring programs conducted side-by-side comparisons for their instruments:

- 1) ODU compared the YSI rapid-pulse Clark-cell sensor to the YSI Optical (ODO) sensor;
- 2) MDNR compared the Hydrolab® Clark-cell sensor to the Hydrolab® luminescent (LDO) sensor and to the YSI ODO sensor; and
- 3) VADEQ compared the Hydrolab® Clark-cell sensor to the YSI ODO sensor.

**OTHER ISSUES:** None

**OTHER DOCUMENTATION:** None

**TITLE:** DISSOLVED OXYGEN SATURATION  
**PARAMETER NAME (NEW):** DO\_SAT  
**PARAMETER NAME (OLD):** DO\_SAT  
**UNITS OF MEASURE:** mg/L  
**METHOD CODES:** See Methods Table

**GENERAL METHOD:**

DO\_SAT is a calculated value representing the dissolved oxygen concentration at saturation for that water temperature and salinity. This is calculated from an equation provided by Hydroqual:

$$\text{DO\_SAT} = 14.6244 - 0.367134 * \text{WTEMP} + 0.0044972 * \text{WTEMP} * \text{WTEMP} \\ - 0.0966 * \text{SALINITY} + 0.00205 * \text{SALINITY} * \text{WTEMP} \\ + 0.0002739 * \text{SALINITY} * \text{SALINITY};$$

**METHOD CHANGES:**

None

**DAITS ISSUES:**

None

**OTHER ISSUES:**

None

**OTHER DOCUMENTATION:**

None

**TITLE:** PH  
**PARAMETER NAME (NEW):** PH  
**PARAMETER NAME (OLD):** PH  
**UNITS OF MEASURE:** Standard units  
**METHOD CODES:** See Methods Table

**GENERAL METHOD:**

Refer to "Dissolved Oxygen" for physical profile methods.

**METHOD CHANGES:**

ODU: From June 1984 to April 1986, pH was not measured as part of the vertical profile. pH was measured by a sensor on the research vessel only at depths where samples were collected.

**DAITS ISSUES:**

None

**OTHER ISSUES:**

Source=VIMS did not measure pH as part of the vertical profile. They collected aliquots of the nutrient samples and measured pH onboard the research vessel with a pH meter. A data query for these measurements will be the same as for nutrient data.

**OTHER DOCUMENTATION:**

None

**TITLE:** SALINITY  
**PARAMETER NAME (NEW):** SALINITY  
**PARAMETER NAME (OLD):** SALIN  
**UNITS OF MEASURE:** PPT  
**METHOD CODES:** See Methods Table

**GENERAL METHOD:**

Refer to "Dissolved Oxygen" for physical profile methods.

The salinity value is either read directly when using a Hydrolab Surveyor II (MDE and ODU), or computed later from conductivity (SPCOND) and water temperature (WTEMP) when using a CTD (VIMS).

VIMS: VIMS compared its CTD salinity measurements with a Beckman Salinometer and submitted these values as the variable SALIN2.

**METHOD CHANGES:**

Salinity is calculated by the Hydrolab Surveyor II (MDE and ODU) from specific conductance (at 25 degree C) using the following formula:

\*Convert micromhos to millimhos;  
 $SPCOND = SPCOND/1000;$

\*Hydrolab salinity is calculated from temperature corrected conductance @25 degree C millimhos/cm;  
 $SPCOND2 = SPCOND - 32.188;$   
 $SALIN2 = 20 + 0.69608*SPCOND2 + 1.3094E-3*(SPCOND2**2) - 11.918E-6*(SPCOND2**3) + 173.92E-9*(SPCOND2**4) - 3.1112E-9*(SPCOND2**5);$

VIMS used the UNESCO (Fofanoff and Millard 1983) equation for calculating the CTD measured salinity from conductivity. Conductivity is temperature corrected as part of the equation (to 15 degree C) but the original (raw) values are reported to CBPO.

**DAITS ISSUES:**

None

**OTHER ISSUES:**

None

**OTHER DOCUMENTATION:**

See Fofanoff and Millard (1983), "Algorithms for computation of fundamental properties of seawater," and Hydrolab technical manuals (Hydrolab 1984).

**TITLE:** SECCHI DISK DEPTH  
**PARAMETER NAME (NEW):** SECCHI  
**PARAMETER NAME (OLD):** SECCHI  
**UNITS OF MEASURE:** Meters  
**METHOD CODES:** See Methods Table

**GENERAL METHOD:**

A black-and-white Secchi disk attached to a ruled line is lowered into the water. The depth at which the disk disappears is averaged with the depth at which it reappears; this measurement (in meters) is the Secchi depth (SECCHI).

**METHOD CHANGES:**

The disk may be either 20 or 30 cm wide.

**DAITS ISSUES:**

#007 – Secchi variability and time of sampling are discussed.  
#044 – Secchi Hits Bottom and still visible.

**OTHER ISSUES:**

In most cases, station depths exceed the relatively shallow Secchi depths observed in recent times. There are, however, shallow stations in the tributaries where the disk is still visible at the bottom, i.e., where Secchi depth exceeds total depth. In these cases, the true value of Secchi depth is unknown and the QUALIFIER variable should be set to '>' to flag these instances. In practice, however, use of the flag is inconsistent for Secchi depth.

The value for SECCHI is sometimes missing due to the time of day the station was sampled (see DAITS #7 for details). SECCHI data are to be collected only within 1/2 hour before to 1/2 hour after sunrise and sunset respectively.

Secchi depth, like station depth, pycnocline depth and weather conditions, is an attribute of a station at the time of sampling and is not related to any particular depth in the station's vertical profile. However, for data management purposes and efficiency of data retrieval, Secchi depth is also stored in data tables with depth-specific water quality measurements. There, Secchi depth is associated with the depth of the surface measurement with layer='S'. It may also appear with depth=0m and layer='S', where depth-specific parameter data are associated with the actual sample depth.

**OTHER DOCUMENTATION:**

Poster COL-09.A12 by Jurate M.Landwehr entitled "[Spatial and Temporal Variability in the Kd-Secchi Conversion Coefficient Observed among the Tidal Tributary Rivers of the Chesapeake Bay Watershed](#)". This work demonstrates that the use of a single conversion coefficient to transform Secchi depth measurements into light attenuation coefficients to assess the percent light through the water column available at depth may lead to an erroneous assessment of compliance or noncompliance with the newly published (EPA 2003) ambient water quality criteria for water clarity for the tidal rivers of the Chesapeake Bay system.

**TITLE:** LIGHT ATTENUATION  
**PARAMETER NAME (NEW):** KD  
**PARAMETER NAME (OLD):** KD  
**UNITS OF MEASURE:** None  
**METHOD CODES:** D01

Data collected from this procedure can provide a measure of water clarity and be used to estimate depth of the photic zone.

**GENERAL METHOD:**

Down welling light penetrating the water column (Photosynthetically Active Radiation (PAR, 400-700nm)) is measured underwater at several depths to calculate the light attenuation coefficient,  $K_d$ . Simultaneous on-deck and submersed PAR intensity measurements are taken into account for variability in incident surface irradiance due to changes in cloud cover.

The procedure is as follows: Simultaneously measure PAR in air, on deck, and downwelling PAR measured underwater with sensor pointed up, beginning just below the surface and continuing at depth intervals appropriate to the location until the meter indicates <10% of the initial subsurface value or until the bottom is reached.

There are preliminary adjustments to the deep and shallow PAR readings based on variations in the on-deck readings, but in essence,

$$KD = - (\log(\text{deepest\_PAR}) - \log(\text{shallowest\_PAR})) / (\text{depth of deepest PAR reading} - \text{depth of shallowest PAR reading}).$$

**METHOD CHANGES:**

In 1992, it was decided to collect and submit photosynthetically active radiation (PAR) from which KD and depth of the photosynthetic zone could be calculated. No direction was provided by the CBP for collecting or submitting the data. There are, therefore, some inconsistencies in the variables submitted and methods for calculating KD in the early years. See DAITS #038 for some specifics.

**DAITS ISSUES:**

#036 – Downward Facing Light Attenuation Sensor - Initially, ODU also collected downward-facing PAR data to be able to correct for bottom reflected light. At present, in areas currently sampled in the Bay, there are no areas where light penetrates to the bottom and there is, therefore, no need to correct for bottom reflected light.

#038 – Light Attenuation Parameter Names and KD Calculation - There are some discrepancies between the parameter names for the PAR readings used to calculate KD in the CBP water quality database and the documentation for those parameters. Because of confusion between the terms downwelling, upwelling, down facing sensor and upward facing sensor, the parameter name EPARU\_Z originally intended for the upwelling reading with sensor facing down, was used for upward facing sensor to record downwelling. EPARD\_Z now refers to down facing sensor used to record upwelling. Since downwelling values named EPARU\_Z have been



submitted for some time and data sheets and computer software both at the CBP and data submitter sites, use this parameter name, it was decided to keep the name the same and make the appropriate changes in the documentation. This issue was discussed and agreed upon at the April 24, 2003 Analytical Methods and Quality Assurance Workgroup (AMQAW).

OTHER ISSUES:

None

OTHER DOCUMENTATION:

Poster COL-09.A12 by Jurate M.Landwehr entitled "[Spatial and Temporal Variability in the Kd-Secchi Conversion Coefficient Observed among the Tidal Tributary Rivers of the Chesapeake Bay Watershed](#)". This work demonstrates that the use of a single conversion coefficient to transform commonly available Secchi depth measurements into light attenuation coefficients in order to assess the per cent light through the water column available at depth may lead to an erroneous assessment of compliance or noncompliance with the newly published (EPA 2003) ambient water quality criteria for water clarity for the tidal rivers of the Chesapeake Bay system.

**TITLE:** SPECIFIC CONDUCTANCE  
**PARAMETER NAME (NEW):** SPCOND  
**PARAMETER NAME (OLD):** COND  
**UNITS OF MEASURE:** umhos/cm at 25 degree C  
**METHOD CODES:** See Methods Table

**GENERAL METHOD:**

Refer to "Dissolved Oxygen" for physical profile methods.

**METHOD CHANGES:**

ODU submitted SPCOND as mmhos/cm until March 1992, when they started sending it as umhos/cm. ODU SPCOND values did not appear to be temperature corrected before October 1986, and were not always corrected until October 1989. ODU used a Beckman RS-5-3 meter for early measurements and a Hydrolab Surveyor II until 1997, which has a temperature correction, so reasons for this discrepancy are not clear.

The Hydrolab Surveyor II, used in the past by MDE and ODU, does a temperature correction of about 2% per degree C above or below 25 degree C, as follows (using SAS code, adapted from Hydrolab 1984):

\*Convert micromhos to millimhos to use Hydrolab equation:

SPCOND = SPCOND/1000;

CORRFAC = 1 + 0.0208\*(WTEMP - 25) + 108.2E-6\*((WTEMP-25)\*\*2);

SPCOND\_C = SPCOND / CORRFAC;

\*Convert unites back to micromhos;

SPCOND = SPCOND\_C\*1000;

LABEL SPCOND='SPECIFIC CONDUCTANCE MICROMHOS/CM AT 25 C';

VIMS used a CTD that measures conductivity without temperature correction, and they report that as SPCOND. The Hydrolab equation may be used to make their SPCOND values comparable to MDE and ODU values. The older ODU values may also be temperature corrected if desired.

**DAITS ISSUES:**

#025 – "Pycnocline calculation methods." SPCOND is used to determine the threshold used for pycnocline determination.

#040 – "Pycnocline Calculation: Different methods for WQ sample collections and for Designated Use boundary delineation." One method uses conductivity as a surrogate for water density and a relative measure of difference to determine a pycnocline; the other uses a constant, fixed difference in water densities, with density calculated from water temperature and salinity.

**OTHER ISSUES:** None

**OTHER DOCUMENTATION:** None

**TITLE:** WATER TEMPERATURE  
**PARAMETER NAME (NEW):** WTEMP  
**PARAMETER NAME (OLD):** WTEMP  
**UNITS OF MEASURE:** Degrees Celsius  
**METHOD CODES:** See Methods Table

**GENERAL METHOD:**

Refer to "Dissolved Oxygen" for physical profile methods. A thermistor is used, in a sonde (ODU) or CTD (VIMS). Temperature readings cannot be adjusted in the sonde; the unit must be sent in for service if out of calibration. MDE checks the temperature calibration of the Hydrolab thermistor against a NIST calibrated thermometer at least twice a year. ODU checks the temperature calibration of the thermistor against a NIST traceable thermometer at least once a year.

**METHOD CHANGES:**

None

**DAITS ISSUES:**

None

**OTHER ISSUES:**

None

**OTHER DOCUMENTATION:**

None

**TITLE:** SPECIFIC GRAVITY  
**PARAMETER NAME (NEW):** SIGMA\_T  
**PARAMETER NAME (OLD):** SIG\_T  
**UNITS OF MEASURE:** None  
**METHOD CODES:** D01

**GENERAL METHOD:**

Specific gravity (water density) is calculated from:

```
sigo= -0.069+((1.47808*((salin-0.03)/1.805))
        -(0.00157*(((salin-0.03)/1.805)**2))
        +(0.0000398*(((salin-0.03)/1.805)**3)));
tsum=(-1*(((wtemp-3.98)**2)/503.57))*((wtemp+283)/(wtemp+67.26));
sa= ((10**-3)*wtemp)*(4.7867-(0.098185*wtemp)+(0.0010843*
        (wtemp**2)));
sb= ((10**-6)*wtemp)*(18.030-(0.8164*wtemp)+(0.01667*(wtemp**2)));

SIG_T = tsum+((sigo+0.1324)*(1-sa+sb*(sigo-0.1324)));
```

**METHOD CHANGES:**

None

**DAITS ISSUES:**

None

**OTHER ISSUES:**

None

**OTHER DOCUMENTATION:**

Derived from equations in Sverdrup, H.U., M.W. Johnson, and R.H. Fleming. 1942. The Oceans. Prentice-Hall, Inc. Englewood Cliffs, NJ. 1087 pp. The formulas for density are in pp. 56-60.

**TITLE:** FIELD FILTRATION METHODS  
**PARAMETER NAME:** (affects all dissolved and particulate parameters)  
**UNITS OF MEASURE:** None  
**METHOD CODES:** None

**GENERAL METHODS:**

All dissolved parameters are analyzed from water filtered in the field, to minimize changes in the sample caused by biological activity after sample collection. All parameters are filtered using a vacuum pump, except DOC/PC/PN filtration at ODU used positive pressure filtration with a syringe until 1992. Whether or not the filter was rinsed after filtration also varied: TSS/PP filters are always rinsed with deionized (DI) water, because the salt prevents accurate TSS determination if the filter is unrinsed. PC/PN filters were rinsed by VIMS with DI water until 1992, but were never rinsed by ODU or MDE field crews. CHLA filters have magnesium carbonate added at all mainstem laboratories.

The filtrate used for dissolved nutrient analysis varies: MDE/CBL uses the PC/PN filtrate, while ODU and VIMS use the TSS/PP filtrate, removing it from the filter apparatus before the TSS/PP filter is rinsed with DI water. The filtrate used for DOC also varies: CBL and ODU use the PC/PN filtrate for DOC analyses, while VIMS uses the TSS/PP filtrate for DOC.

**METHOD CHANGES:**

MDE and VIMS field crews used 0.45 micron membrane filters at the start of the program in June 1984. ODU field crews have used 0.7 micron glass fiber filters (Whatman GF/F, except for CHLA and PC/PN) since the start of the program. VIMS changed to 0.7 micron glass fiber filters in June 1985, and MDE crews made this change on May 15, 1985. A study by Magnien (1986) showed there were no statistically significant differences in any dissolved parameters filtered by the two methods, except for small differences in silica concentrations.

The change in filter type was made for two reasons: membrane filters tend to clog when TSS is high, and there are possible contamination problems with nutrients released by the membrane filter.

VIMS previously used the PC/PN filtrate for DOC, but switched to using the TSS/PP filtrate when they had contamination problems.

**DAITS ISSUES:**

#023 - Effects of filter rinsing on PC/PN results are discussed.

**OTHER ISSUES:**

VIMS and ODU used Gelman AE glass fiber filters for their PC/PN determinations, because Whatman GF/F filters were not available in the diameter they needed. Both now use Whatman GF/F. In May 2001, ODU began using 25mm GF/F filters instead of 13mm GF/F filters for PC/PN.

ODU used Whatman GF/C filters for CHLA filtration until 1992, when they switched to

Whatman GF/F. GF/C has slightly larger pore size (1.0 micron). ODU ground CHLA filters on the boat, unless seas were too rough; ODU started grinding in the laboratory in 1992. MDE and VIMS grind CHLA filters in the laboratory.

OTHER DOCUMENTATION:

"A comparison of estuarine water chemistry analysis on the filtrate from two types of filters" (Magnien 1986).

["Estuarine nutrient analyses: A comparison of sample handling techniques and analyses of carbon, nitrogen, phosphorus, and chlorophyll a"](#) (Zimmermann 1991).

**TITLE:** TOTAL PHOSPHORUS  
**PARAMETER NAME (NEW):** TP  
**PARAMETER NAME (OLD):** TP  
**UNITS OF MEASURE:** mg/l as P  
**METHOD CODES:** See Methods Table

**GENERAL METHODS:**

Direct: An unfiltered water sample is digested in acid and persulfate to convert all forms of phosphorus to orthophosphate. Then orthophosphate is determined with the autoanalyzer.

Calculated: TDP + PP (see those parameters for details). This is the currently preferred method.

**METHOD CHANGES:**

Major method changes have occurred. The change to TP calculated was made to eliminate any parameters calculated by subtraction, since calculations by subtraction were shown to be less accurate and can yield negative values (see D'Elia et al. 1987). No step trends have been identified associated with these method changes. This change occurred early, in 1987, in the main Bay program and later, at different times, in the MD and VA tributary programs.

**DAITS ISSUES:**

#010 - Summarizes early method comparison data available to document comparability of old and new TP methods.

#016 - Based on split sample data from 1987-1990, MDHMH data for Total Phosphorus (TP) and Total Dissolved Phosphorus (TDP) were higher than comparable results from CBL, ODU, or VIMS. The MDHMH results for TP and TDP were usually about 0.03 - 0.05 mg/l higher than the results from the other laboratories. A correction factor was developed and applied to the majority of the 1985-1990 data in the database.

#042 - Analytical Method Changes in Total Phosphorus Measurements for the Virginia Tributaries. Discusses the nature of the step trend observed in TP pre- and post-method change that occurred in 1995. A correction factor was developed to be applied only when comparing data before and after 1995.

#043 - Comparability of parameter estimates from whole water and filtered samples for MD Department of Health and Mental Hygiene data; mostly non-tidal freshwater stations. In this study, there appears to be little difference between TP measured directly in whole water and TP calculated from PP plus TDP measured in filtered samples. Based on analysis of the method differences, it does not appear necessary to adjust whole water TP concentrations for analyses that include data from both methods.

**OTHER ISSUES:**

Inter-organization agreement among mainstem laboratories is high, based on CSSP data (AMQAW 1992).

**OTHER DOCUMENTATION:**

Chesapeake Bay Coordinated Split Sample Program Annual Reports ([AMQAW](#)).

"Trends in Phosphorus in the Chesapeake Bay (1984-1990)" (CSC 1991).

["Nitrogen and phosphorus determinations in estuarine waters: a comparison of methods used in Chesapeake Bay Monitoring"](#) (D'Elia et al. 1987).



**TITLE:** TOTAL DISSOLVED PHOSPHORUS  
**PARAMETER NAME (NEW):** TDP  
**PARAMETER NAME (OLD):** TDP  
**UNITS OF MEASURE:** mg/l as P  
**METHOD CODES:** See Methods Table

**GENERAL METHOD:**

All laboratories digest a filtered sample to convert all forms of dissolved phosphorus to inorganic phosphorus (PO<sub>4</sub>F), which is analyzed using with the same autoanalyzer manifold as PO<sub>4</sub>F. ODU calibrates by the method of standard additions, using standards diluted in a composite of water from several samples.

**METHOD CHANGES:**

No major method changes. Minor changes occurred in the digestion method used (acid or alkaline persulfate). Comparisons between results from the two digestion methods showed slightly higher results with acid persulfate, but the magnitude of the differences was fairly small (about 0.005 mg/l, see Figure 15 in D'Elia et al. 1987).

**DAITS ISSUES:**

#016 - Based on split sample data from 1987-1990, MDHMH data for Total Phosphorus (TP) and Total Dissolved Phosphorus (TDP) were higher than comparable results from CBL, ODU, or VIMS. The MDHMH results for TP and TDP were usually about 0.03 - 0.05 mg/l higher than the results from the other laboratories.

**OTHER ISSUES:**

Inter-laboratory agreement among the three mainstem laboratories (CBL, VIMS, and ODU) is high for TDP, based on Coordinated Split Sample Program (CSSP) data (AMQAW).

Sometimes TDP results are less than PO<sub>4</sub>F results, even though theoretically they should be equal to or greater than PO<sub>4</sub>F. The discrepancy may have two causes: TDP involves a digestion and PO<sub>4</sub>F does not, and material may be lost during digestion; TDP also involves an internal dilution, and PO<sub>4</sub>F does not. When TDP < PO<sub>4</sub>F, laboratories should use analytical problem code 'QQ' and leave both values in the database if the discrepancy is less than the analytical precision, usually estimated by the sum of both MDLs. If the discrepancy is larger than the summed MDLs, one or both values may be deleted.

**OTHER DOCUMENTATION:**

"Chesapeake Bay Coordinated Split Sample Program Annual Reports ([AMQAW](#)).

["Nitrogen and phosphorus determinations in estuarine waters: a comparison of methods used in Chesapeake Bay Monitoring"](#) (D'Elia et al. 1987).

**TITLE:** PARTICULATE PHOSPHORUS  
**PARAMETER NAME (NEW):** PP  
**PARAMETER NAME (OLD):** PHOSP  
**UNITS OF MEASURE:** mg/l as P  
**METHOD CODES:** See Methods Table

**GENERAL METHODS:**

Calculated: From TP - TDP.

Direct: The same filter weighed for TSS determination may be used in direct determination of PP. After weighing, the filter is placed in a crucible and heated in a muffle furnace at 550 C. The combustion breaks down organically bound phosphorus to inorganic phosphorus (orthophosphate), which is extracted with hydrochloric acid and determined with an autoanalyzer. The method is from Aspila et al. (1976). This is the preferred method.

**METHOD CHANGES:**

Major method changes have occurred. The change to PP measured directly was made to avoid having to calculate any parameters by subtraction, since calculations by subtraction were shown to be less accurate and can yield negative values (see D'Elia et al. 1987). No step trends have been identified associated with these method changes.

**DAITS ISSUES:**

#010 - Summarizes early method comparison data available to document comparability of old and new PP methods.

#016 - If Maryland mainstem data is being combined with Maryland tributary data for PP, the differences found in TP and TDP results from Maryland mainstem and Maryland tributary monitoring programs probably also affected PP. See TP or TDP for details.

**OTHER ISSUES:**

PP may show a positive correlation with TSS, since it is contained in plankton and it may adhere to soil particles. These parameters can be compared when examining possible outliers in the data.

Note that calculated parameters derived by subtraction can be negative.

Inter-organization agreement among mainstem laboratories is high, based on CSSP data (AMQAW).

**OTHER DOCUMENTATION:**

Chesapeake Bay Coordinated Split Sample Program Annual Reports ([AMQAW](#)).

["Nitrogen and phosphorus determinations in estuarine waters: a comparison of methods used in Chesapeake Bay Monitoring"](#) (D'Elia et al. 1987).

"A semi-automated method for the determination of inorganic, organic, and total phosphate in sediments" (Aspila, I. et al. 1976).

**TITLE:** **ORTHOPHOSPHATE (FILTERED) AND DISSOLVED INORGANIC PHOSPHORUS**  
**PARAMETER NAME (NEW):** **PO4F and DIP**  
**PARAMETER NAME (OLD):** **PO4F and DIP**  
**UNITS OF MEASURE:** **mg/l as P**  
**METHOD CODES:** **See Methods Table**

**GENERAL METHOD:**

All laboratories use variants of EPA method 365, ascorbic acid reduction, with an autoanalyzer, except ODU used a manual method until 1992. ODU analyzed by the method of standard additions until May 1997, using standards diluted in a composite of sample water. CBL and VIMS use a double reagent method (ascorbic acid as a separate reagent); see Zimmermann (1991).

**METHOD CHANGES:**

ODU changed from manual to autoanalyzer method in 1992.

**DAITS ISSUES:**

#015 - CBL revised their PO4F data with a salinity correction 8/28/1992. This did not affect other phosphorus parameters, although they are analyzed as PO4F after digestion, because the additional reagents used for TP, TDP, and PP change the refractive index of the solution and eliminate the need for the correction. This is an issue when using tidal Potomac River data.

#043 - Comparability of parameter estimates from whole water and filtered samples for MD Department of Health and Mental Hygiene data. Mostly affects non-tidal freshwater stations. The analysis of PO4 in this context revealed significant differences in PO4 estimates between whole water and filtered samples ( $PO_{4W} > PO_{4F}$ ), and it is recommended that where a method change from whole to filtered water has occurred, an adjustment factor be applied to the PO4W concentrations before analyses are conducted including data from both period.

**OTHER ISSUES:**

Orthophosphate (filtered) is considered equivalent to dissolved inorganic phosphorus (DIP). PO4F may include a small amount of organic P, and it does not include one form of inorganic P, called "hydrolyzable phosphate." The magnitude of these two components in Bay PO4F samples is unknown, but both are assumed to be small. Hydrolyzable phosphate is mainly found in detergents, and its use is now banned in most detergents. Hydrolyzable phosphate should be included in TDP and TP determinations, however. PO4F is exactly equivalent to Soluble Reactive Phosphorus (SRP) used in oceanographic research.

Orthophosphate (filtered) is released (mineralized) from sediments under anoxic conditions, which usually occur in the summer. Thus, maximum values are often found in summer bottom samples.

Orthophosphate (filtered) values are sometimes below the detection limit, complicating trend analyses. Orthophosphate (filtered) values may exceed TDP values; see TDP for more information.

A habitat requirement for Submerged Aquatic Vegetation (SAV) growth has been established for DIP. April-October median surface values should be less than 0.01 mg/l in lower salinity regions, and less than 0.02 mg/l in higher salinity regions (>18 ppt). See Batiuk et al. (1992) for details.

In some historical Chesapeake Bay data (before 1984), PO<sub>4</sub>F may have been reported as mg/l PO<sub>4</sub> instead of as mg/l P. All concentrations should have been converted, but if high results are found for a particular time period, they may have been reported as PO<sub>4</sub>.

Inter-organization agreement among mainstem laboratories is high, based on CSSP data (AMQAW).

#### OTHER DOCUMENTATION:

Analytical Methods and Quality Assurance Workgroup ([AMQAW](#)). 1992. Chesapeake Bay Coordinated Split Sample Program Annual Report, 1990-1991. CBP/TRS 76/92, Chesapeake Bay Program, Annapolis, MD.

CSC. 1991. Trends in Phosphorus in the Chesapeake Bay (1984-1990). CBP/TRS 67/91, Chesapeake Bay Program, Annapolis, MD.

Zimmermann, C. 1991. [Estuarine nutrient analyses: A comparison of sample handling techniques and analyses of carbon, nitrogen, phosphorus, and chlorophyll a](#). Report submitted to EPA through Technology Applications, Inc. by Chesapeake Biological Laboratory, Solomons, MD.

**TITLE:** DISSOLVED ORGANIC PHOSPHORUS  
**PARAMETER NAME (NEW):** DOP  
**PARAMETER NAME (OLD):** DOP  
**UNITS OF MEASURE:** mg/l as P  
**METHOD CODES:** See Methods Table

**GENERAL METHOD:**

Calculated from TDP - PO4F for all laboratories and time periods, assuming PO4F = DIP.

**METHOD CHANGES:**

No major method changes.

**DAITS ISSUES:**

None

**OTHER ISSUES:**

Because Orthophosphate (filtered) (PO4F) may include a small amount of organic P, the calculation method used may underestimate DOP slightly. However, DOP calculated by this method may be slightly overestimated if hydrolyzable phosphate is present.

DOP can be negative, since PO4F sometimes exceeds TDP.

**OTHER DOCUMENTATION:**

None

**TITLE:** TOTAL NITROGEN  
**PARAMETER NAME (NEW):** TN  
**PARAMETER NAME (OLD):** TN  
**UNITS OF MEASURE:** mg/l as N  
**METHOD CODES:** See Methods Table

**GENERAL METHOD:**

Total nitrogen is always calculated, either from TKNW + NO23F or TDN + PN.

**METHOD CHANGES:**

Major method changes have occurred. The change to  $TN = TDN + PN$  was made to avoid having to calculate any parameters by subtraction, since calculations by subtraction were shown to be less accurate and often yield negative values (see D'Elia et al. 1987). Step trends have been identified associated with these method changes (see DAITS issues). TN data in the main Bay CBP database prior to October 1987 have been adjusted to correct for both step trends.

VADEQ: VADEQ made the change to (TDN + PN) from (TKNW + NO23F) in 1995 (see DAITS issue #041 below). Side-by-side comparability was not evaluated at that time. An intervention analysis in 1994 indicated a positive step trend in 51 of 63 (81%) stations.

**DAITS ISSUES:**

#002 - Adjusting helix Kjeldahl nitrogen data (see Bergstrom 1992). Used method comparison data to correct a low bias in early TKNW and TKNF data from OEP/CRL, and thus TN and TDN data.

#010 - Summarizes method comparison data available to document comparability of old and new TN methods.

#020 - Adjustment for ODU TN Kjeldahl data. Used dummy variables from TN regression to adjust ODU TN data; no adjustment made to TKNW data.

#041 - Analytical Method Changes in Total Nitrogen Measurements for the Virginia Tributaries. Discusses the nature of the step trend observed in TN pre- and post-method change.

#043 - Comparability of parameter estimates from whole water and filtered samples for MD Department of Health and Mental Hygiene data; mostly non-tidal freshwater samples. In the case of total nitrogen, the comparison involved TN estimates obtained from whole water parameters TKNW plus NO23W compared to TN obtained from filtered parameters PN plus TDN. Based on analysis of the differences between the methods, no adjustment is necessary.

**OTHER ISSUES:**

Inter-organization agreement among mainstem laboratories was fairly low, based on CSSP data (AMQAW). The difference was probably due to the difference in PN (PON) results, since it followed the same pattern; see PN for details.

OTHER DOCUMENTATION:

Analytical Methods and Quality Assurance Workgroup (AMQAW). 1992. Chesapeake Bay Coordinated Split Sample Program Annual Report, 1990-1991. CBP/TRS 76/92, Chesapeake Bay Program, Annapolis, MD.

Bergstrom, P. 1992. Adjusting helix Kjeldahl nitrogen results: Maryland Chesapeake Bay Mainstem Water Quality Monitoring Program, 1984-1985. CBP/TRS 44/92, Chesapeake Bay Program, Annapolis, MD.

Chesapeake Bay Program (CBP). 1992. Trends in Nitrogen in the Chesapeake Bay (1984-1990). CBP/TRS 68/92, Chesapeake Bay Program, Annapolis, MD.

D'Elia, C. et al. 1987. [Nitrogen and phosphorus determinations in estuarine waters: a comparison of methods used in Chesapeake Bay Monitoring](#). CBP/TRS 7/87, Chesapeake Bay Program, Annapolis, MD.



**TITLE:** TOTAL DISSOLVED NITROGEN  
**PARAMETER NAME (NEW):** TDN  
**PARAMETER NAME (OLD):** TDN  
**UNITS OF MEASURE:** mg/l as N  
**METHOD CODES:** See Methods Table

**GENERAL METHOD:**

Direct (Preferred): Laboratories digest a filtered sample with alkaline persulfate to convert all forms of dissolved nitrogen to nitrite + nitrate (NO<sub>2</sub>3F), which is analyzed with the same autoanalyzer manifold as NO<sub>2</sub>3F. See D'Elia et al. (1987).

Calculated: from TDN = TKNF + NO<sub>2</sub>3F.

**METHOD CHANGES:**

Major method changes have occurred. The change to TDN direct was made to avoid having to calculate any parameters by subtraction, since calculations by subtraction were shown to be less accurate and could yield negative values (see D'Elia et al. 1987). Step trends have been identified associated with these method changes (see DAITS issues); TDN data in the CBP main Bay database have been adjusted to correct for one step trend in the pre1987 period (see DAITS issues and Bergstrom 1992).

In May 1998, MD tidal tributary nutrient analyses of Potomac and minor tributary sampled switched from DHMH to CBL. Patuxent River changes in July 1990. DHMH did not analyze TDN directly.

In 2009, CBL began using an enzyme-catalyzed reduction step in place of cadmium-copper reduction.

**DAITS ISSUES:**

#002 - Adjusting helix Kjeldahl nitrogen data (see Bergstrom 1992). Used method comparison data to correct a low bias in early TKNW and TKNF data from OEP/CRL, and thus TDN data.

#010 - Summarizes method comparison data available to document comparability of old and new TDN methods.

#020 - Adjustment for ODU TN Kjeldahl data. Used dummy variables from TN regression to adjust ODU TN data; no adjustment done to TKNF or TDN data.

#043 - Comparability of parameter estimates from whole water and filtered samples for MD Department of Health and Mental Hygiene data

**OTHER ISSUES:**

Inter-organization agreement among mainstem laboratories is generally high, based on CSSP data (AMQAW).

OTHER DOCUMENTATION:

Analytical Methods and Quality Assurance Workgroup (AMQAW). 1992. Chesapeake Bay Coordinated Split Sample Program Annual Report, 1990-1991. CBP/TRS 76/92, Chesapeake Bay Program, Annapolis, MD.

Bergstrom, P. 1992. Adjusting helix Kjeldahl nitrogen results: Maryland Chesapeake Bay Mainstem Water Quality Monitoring Program, 1984-1985. CBP/TRS 44/92, Chesapeake Bay Program, Annapolis, MD.

D'Elia, C. et al. 1987. [Nitrogen and phosphorus determinations in estuarine waters: a comparison of methods used in Chesapeake Bay Monitoring](#). CBP/TRS 7/87, Chesapeake Bay Program, Annapolis, MD.

**TITLE:** PARTICULATE NITROGEN  
**PARAMETER NAME (NEW):** PN  
**PARAMETER NAME (OLD):** PON  
**UNITS OF MEASURE:** mg/l as N  
**METHOD CODES:** See Methods Table

**GENERAL METHOD:**

Particulate nitrogen in Bay waters is assumed to consist primarily of organic nitrogen. In the early years of the Monitoring Program, particulate nitrogen was calculated from TKNW - TKNF and called PON. Later, the direct method was adopted, and all laboratories determine particulate nitrogen from a separate filter that is combusted at 975-1050 C using an elemental analyzer. The results may include some inorganic nitrogen.

In the current CIMS database, including any calculated values from the earlier period, the parameter name is for particulate nitrogen is PN.

**METHOD CHANGES:**

Major method changes have occurred. The change to PN direct was made in order to avoid having to calculate parameters by subtraction, since calculations by subtraction were shown to be less accurate and could yield negative values (see D'Elia et al. 1987). Step trends have been identified associated with these method changes (see DAITS issues). PN data in the CBP database have been adjusted to correct for one step trend (see below).

**DAITS ISSUES:**

#002 - Adjusting helix Kjeldahl nitrogen data (see Bergstrom 1992). Used method comparison data to correct a low bias in early TKNW and TKNF data from OEP/CRL, and thus PON data.

#010 - Summarizes method comparison data available to document comparability of old and new PON methods.

#020 - Adjustment for ODU TN Kjeldahl data. Used dummy variables from TN regression to adjust ODU TN data; no adjustment done to PON data.

#023 - Effects of filter rinsing on POC/PON results. Results pending, data being collected by VIMS. Contact Betty Salley for more information.

#043 - Comparability of parameter estimates from whole water and filtered samples for MD Department of Health and Mental Hygiene data.

**OTHER ISSUES:**

Inter-organization agreement among mainstem laboratories was low, based on CSSP data (AMQAW). Results were significantly higher from CBL than at VIMS or ODU. This was apparently due to filter rinsing at VIMS, which caused loss of PN, and positive pressure filtration at ODU. In 1992, VIMS stopped rinsing, and ODU switched to vacuum filtration in 1992, which should increase agreement. Also, VIMS and ODU use a different elemental analyzer from CBL.

OTHER DOCUMENTATION:

Analytical Methods and Quality Assurance Workgroup (AMQAW). 1992. Chesapeake Bay Coordinated Split Sample Program Annual Report, 1990-1991. CBP/TRS 76/92, Chesapeake Bay Program, Annapolis, MD.

Bergstrom, P. 1992. Adjusting helix Kjeldahl nitrogen results: Maryland Chesapeake Bay Mainstem Water Quality Monitoring Program, 1984-1985. CBP/TRS 44/92, Chesapeake Bay Program, Annapolis, MD.

D'Elia, C. et al. 1987. [Nitrogen and phosphorus determinations in estuarine waters: a comparison of methods used in Chesapeake Bay Monitoring](#). CBP/TRS 7/87, Chesapeake Bay Program, Annapolis, MD.

**TITLE:** TOTAL KJELDAHL NITROGEN,  
WHOLE AND FILTERED

**PARAMETER NAME (NEW):** TKNW and TKNF

**PARAMETER NAME (OLD0):** TKNW and TKNF

**UNITS OF MEASURE:** mg/l as N

**METHOD CODES:** See Methods Table

**GENERAL METHOD:**

Kjeldahl nitrogen includes all organic nitrogen, plus part of the inorganic nitrogen (ammonium or NH<sub>4</sub>). Nitrate + Nitrite (NO<sub>3</sub>) is not included. The whole or filtered sample is digested, usually in acid, which converts organic nitrogen to ammonium. The sample is analyzed on the autoanalyzer as ammonium. The main method differences are in the heating method during digestion (see next section).

**METHOD CHANGES:**

There were two minor method changes, although there were three different digestion methods. See Bergstrom 1992 for details. Two step trends have been identified associated with method changes when the Kjeldahl methods were stopped (see DAITS issues); TKNW and TKNF data in the CBP database have been adjusted to correct for only one of the step trends, in Maryland data (see Bergstrom 1992 and DAITS #020).

Both parameters have been discontinued by most, if not all CBP participating laboratories.

**DAITS ISSUES:**

#002 - Adjusting helix Kjeldahl nitrogen data (see Bergstrom 1992). Used method comparison data to correct a low bias in early TKNW and TKNF data using the helix method from OEP/CRL.

#010 - Summarizes method comparison data available to document comparability of old and new TKNW and TKNF methods.

#020 - Adjustment for ODU TN Kjeldahl data. Used dummy variables from TN regression to adjust ODU TN data; no adjustment was done to TKNW data, since regressions were done on TN data only.

**OTHER ISSUES:**

TKNF was not analyzed in bottom samples by VIMS or ODU. This included samples with LAYER = 'B' (bottom) and also LAYER = 'BP' (below pycnocline). This also affected parameters calculated from TKNF: TDN, PON, and Dissolved Organic Nitrogen (DON). MDE laboratories analyzed TKNF in all samples, and TKNW was analyzed in all samples at all laboratories.

Inter-organization agreement among mainstem laboratories could not be assessed with CSSP data because Kjeldahl methods were stopped right after the program started. Earlier two-way split sample data between VIMS and ODU showed significant inter-organization differences for TKNW (Bergstrom 1989). These differences could be a cause of the ODU step trend in TN (see

DAITS #20), since ODU TKNW results were usually higher than VIMS results. TKNF was not analyzed because the samples used were bottom samples.

OTHER DOCUMENTATION:

Bergstrom, P. 1989. Split sample water quality results from laboratories participating in the Chesapeake Bay Program: 1985-1989. CBP/CSSP Report Series #1, Chesapeake Bay Program, Annapolis, MD.

Bergstrom, P. 1992. Adjusting helix Kjeldahl nitrogen results: Maryland Chesapeake Bay Mainstem Water Quality Monitoring Program, 1984-1985. CBP/TRS 44/92, Chesapeake Bay Program, Annapolis, MD.

**TITLE:** NITRITE + NITRATE and NITRATE  
WHOLE and FILTERED  
**PARAMETER NAME (NEW):** NO23W, NO23F ; NO3W, NO3F  
**PARAMETER NAME (OLD):** NO23, NO3  
**UNITS OF MEASURE (NEW):** mg/l as N  
**METHOD CODES:** See Methods Table

**GENERAL METHOD:**

Cadmium reduces NO3 to NO2; then the sum of NO3 and NO2 are determined as NO2 by the diazo method with an autoanalyzer using EPA method 353.2 (Colorimetric, Automated, Cadmium Reduction).

NO3W, NO3F are derived by subtraction:

$$\text{NO3W} = \text{NO23W} - \text{NO2W}; \quad \text{NO3F} = \text{NO23F} - \text{NO2F}$$

**METHOD CHANGES:**

No major method changes in the tidal regions. In 2009, CBL began using an enzyme-catalyzed reduction step in place of cadmium-copper reduction.

ODU originally reported NO23 as "NO3" but this was later corrected in the CBP database. Nitrate has never been measured directly.

**DAITS ISSUES:**

#043 - Comparability of parameter estimates from whole water and filtered samples for MD Department of Health and Mental Hygiene data. Mostly non-tidal freshwater samples. Comparisons of NO23W to NO23F indicate that whole water concentrations usually exceed filtered. The magnitude of the difference greatly exceeds the detection limit (0.002 mg/L), while the difference expressed as a percent of total concentration is small (~4%). An adjustment of NO23W is recommended if data from pre- and post-method change are being used.

**OTHER ISSUES:**

Unfiltered NO23 results have been reported in some tributary monitoring programs and may have been used in historical mainstem data. In the Potomac component of the CSSP, unfiltered NO23 results were slightly higher than filtered results (see AMQAW 1992, DAITS #43). Filtered samples were used starting in October, 1990, which eliminated the difference (AMQAW 1992). In the current CIMS database the unfiltered and filtered measurements are distinguished by different variable names: NO23W and NO23F, respectively.

Inter-organization agreement among mainstem laboratories is high, based on CSSP data (AMQAW).

NO3 is highly soluble in water, and can be present in runoff and ground water in high concentrations (10-15 mg/l in some tributaries). NO3 concentrations may be related to river flow, especially in or near major rivers.

Phytoplankton prefer to use NH4 as a nitrogen source, since it contains more energy, but will

use NO<sub>3</sub> when NH<sub>4</sub> is in short supply. See CBP 1992 for details. Some wastewater treatment plants convert NH<sub>4</sub> to NO<sub>3</sub> (nitrification) to make it less attractive to phytoplankton, raising the NO<sub>3</sub> concentration downstream.

OTHER DOCUMENTATION:

Analytical Methods and Quality Assurance Workgroup (AMQAW). 1992. Chesapeake Bay Coordinated Split Sample Program Annual Report, 1990-1991. CBP/TRS 76/92, Chesapeake Bay Program, Annapolis, MD.

Chesapeake Bay Program (CBP). 1992. Trends in Nitrogen in the Chesapeake Bay (1984-1990). CBP/TRS 68/92, Chesapeake Bay Program, Annapolis, MD.



**TITLE:** NITRITE, WHOLE and FILTERED  
**PARAMETER NAME (NEW):** NO2W, NO2F  
**PARAMETER NAME (OLD):** NO2  
**UNITS OF MEASURE:** mg/l as N  
**METHOD CODES:** See Methods Table

**GENERAL METHOD:**

Determined directly by the automated sulfanilamide method with an autoanalyzer (EPA method 354.1).

**METHOD CHANGES:**

No major method changes.

**DAITS ISSUES:**

#043 - Comparability of parameter estimates from whole water and filtered samples for MD Department of Health and Mental Hygiene data. Mostly non-tidal freshwater samples. Nitrate measurements from whole water samples consistently exceeded those from filtered. While the mean difference between whole and filtered samples only slightly exceeded the detection limit (0.002 mg/L), the mean difference as a percent of mean total (filtered) concentration was relatively large. It is therefore recommended that NO2W data be adjusted before analyzing data including pre- and post-method change data.

**OTHER ISSUES:**

NO2 may often be below the MDL, complicating analyses of this parameter.

NO2 concentrations are usually less than NO3 or NH4 concentrations. It is produced as an intermediate product in nitrification: NH4 is oxidized to NO2, then NO2 is oxidized to NO3.

Inter-organization agreement among mainstem laboratories is high, based on CSSP data (AMQAW 1992).

**OTHER DOCUMENTATION:**

Analytical Methods and Quality Assurance Workgroup (AMQAW). 1992. Chesapeake Bay Coordinated Split Sample Program Annual Report, 1990-1991. CBP/TRS 76/92, Chesapeake Bay Program, Annapolis, MD.

**TITLE:** AMMONIUM, WHOLE AND FILTERED  
**PARAMETER NAME:** NH4W, NH4F  
**PARAMETER NAME:** NH4  
**UNITS OF MEASURE:** mg/l as N  
**METHOD CODES:** See Methods Table

**GENERAL METHOD:**

Determined directly with an autoanalyzer, using the automated alkaline phenol hypochlorite method (EPA 350.1 or equivalent).

**METHOD CHANGES:**

No major method changes.

**DAITS ISSUES:**

#043 - Comparability of parameter estimates from whole water and filtered samples for MD Department of Health and Mental Hygiene data. Mostly non-tidal freshwater samples. The NH4W to NH4F comparisons indicate that whole water concentrations generally exceed filtered, but the mean difference is less than the method detection limit (.008 mg/L) and is also small, considered as percent of sample concentration. Based on these results, adjustment of NH4W in a dataset of pre- and post-method change does not seem warranted.

**OTHER ISSUES:**

NH4 is released (mineralized) by anoxic bottom sediments, usually in the summer. Thus, annual peaks usually occur in summer bottom samples.

Phytoplankton preferentially take up NH4 as a nitrogen source, since it contains more energy, but will use NO23 when NH4 is in short supply. See CBP 1992 for details. Some wastewater treatment plants convert NH4 to NO23 to make it less attractive to phytoplankton (nitrification), lowering the NH4 concentration downstream.

Inter-organization agreement among mainstem laboratories is high, based on CSSP data (AMQAW).

Samples may be susceptible to contamination by ammonium; the detection limits may be under estimated.

**OTHER DOCUMENTATION:**

Analytical Methods and Quality Assurance Workgroup (AMQAW). 1992. Chesapeake Bay Coordinated Split Sample Program Annual Report, 1990-1991. CBP/TRS 76/92, Chesapeake Bay Program, Annapolis, MD.

Chesapeake Bay Program (CBP). 1992. Trends in Nitrogen in the Chesapeake Bay (1984-1990). CBP/TRS 68/92, Chesapeake Bay Program, Annapolis, MD.

**TITLE:** **DISSOLVED INORGANIC NITROGEN**  
**PARAMETER NAME (NEW):** **DIN**  
**PARAMETER NAME (OLD):** **DIN**  
**UNITS OF MEASURE:** **mg/l as N**  
**METHOD CODES:** **See Methods Table**

**GENERAL METHOD:**

Always calculated:  $DIN = (NO_{23W} + NH_{4W})$  or  $(NO_{23F} + NH_{4F})$ , depending on whether constituents are from whole water or filtered samples.

**METHOD CHANGES:**

No major method changes.

**DAITS ISSUES:**

#043 - Comparability of parameter estimates from whole water and filtered samples for MD Department of Health and Mental Hygiene data. Mostly non-tidal freshwater stations. In the case of dissolved inorganic nitrogen, the comparison was between DIN calculated from whole water parameters ( $NO_{23W} + NH_{4W}$ ) and from filtered ( $NO_{23F} + NH_{4F}$ ). Differences indicated that whole exceeds filtered concentrations. The mean difference as a percent of the mean filtered concentration was only 4%; however the mean difference was statistically significant at  $p < .0001$ . It is recommended that the constituents for DIN calculated from whole water parameters be adjusted before the data are combined with filtered data.

**OTHER ISSUES:**

A habitat requirement for Submerged Aquatic Vegetation (SAV) growth has been established for DIN. April-October median surface values should be less than 0.15 mg/l in higher salinity regions (>5 ppt). See Batiuk et al. (1992) for details.

**OTHER DOCUMENTATION:**

Batiuk et al. 1992. Chesapeake Bay Submerged Aquatic Vegetation Habitat Requirements and Restoration Goals: A Technical Synthesis. CBP/TRS 52/92.

Chesapeake Bay Program (CBP). 1992. Trends in Nitrogen in the Chesapeake Bay (1984-1990). CBP/TRS 68/92, Chesapeake Bay Program, Annapolis, MD.

**TITLE:** **DISSOLVED ORGANIC NITROGEN and  
TOTAL ORGANIC NITROGEN**  
**PARAMETER NAME (NEW):** **DON and TON**  
**PARAMETER NAME (OLD):** **DON and TON**  
**UNITS OF MEASURE:** **mg/l as N**  
**METHOD CODES:** **See Methods Table**

**GENERAL METHOD:**

Calculated as follows:

$$\text{DON} = \text{TKNF} - \text{NH}_4 \text{ or } \text{TDN} - \text{NH}_4 - \text{NO}_3;$$

$$\text{TON} = \text{TKNW} - \text{NH}_4 \text{ or } \text{TN} - \text{NH}_4 - \text{NO}_3.$$

**METHOD CHANGES:**

The TKN method has been discontinued in most, if not all CBP laboratories.

**DAITS ISSUES:**

None

**OTHER ISSUES:**

DON can be negative, if NH<sub>4</sub> exceeds TKNF or (NH<sub>4</sub> + NO<sub>3</sub>) exceeds TDN.

TON can be negative, if NH<sub>4</sub> exceeds TKNW or (NH<sub>4</sub> + NO<sub>3</sub>) exceeds TN.

**OTHER DOCUMENTATION:**

None

**TITLE:** TOTAL ORGANIC CARBON  
**PARAMETER NAME (NEW):** TOC  
**PARAMETER NAME (OLD):** TOC  
**UNITS OF MEASURE:** mg/l as C  
**METHOD CODES:** See Methods Table

**GENERAL METHOD:**

Direct: In the 1980's, the three mainstem laboratories used the same method, persulfate oxidation at 100 C, with two different instruments. CBL used an Oceanographic Instruments (OI) ampule instrument, and later an OI injection instrument; ODU used an OI ampule instrument. VIMS never did TOC analyses; ODU analyzed samples from all VIMS stations.

Calculated:  $TOC = DOC + POC$ . This is the preferred method.

**METHOD CHANGES:**

Measurements of DOC were discontinued in the mainstem Bay after 1995. Because TOC is obtained by adding the particulate and dissolved carbon fractions after 1987, discontinuation of DOC resulted in a discontinuation of the mainstem Bay TOC data record after 1995 as well.

In Maryland, EPA Region 3 CRL used manual injection methods which were unreliable, and the data should be used with caution before 5/15/85 (see DAITS #18). CBL changed from OI ampule to OI injection on 3/1/87. See Table 4 for details.

In Virginia, ODU did DOC (and TOC direct until 12/87) for all ODU and VIMS stations until 7/90, when VIMS started DOC analyses for VIMS stations until it was discontinued for the main Bay program after 1995.

**DAITS ISSUES:**

#010 - Summarizes method comparison data available to document comparability of old and new TOC methods.

#018 - Manual injection carbon data. EPA Region 3 CRL used a manual injection method where the results depended on how forcefully the sample was injected. Analytical Methods and Quality Assurance Workgroup (AMQAW) members recommended against using any TOC or DOC results for Maryland mainstem stations before 5/15/85.

#021 - Dissolved organic carbon method comparisons. Salley et al. (1992) summarizes comparisons at VIMS stations; other comparisons at a wider range of salinities are ongoing.

#023 - Effects of filter rinsing on POC/PON results. Results pending, data being collected by VIMS. Contact Betty Salley for more information.

#043 - Comparability of parameter estimates from whole water and filtered samples for MD Department of Health and Mental Hygiene data. Mostly affects non-tidal freshwater stations. In the case of TOC, the comparison was between directly measured TOC in whole water and TOC calculated from  $PC + DOC$  measured in filtered water. The majority of differences are negative,

indicating that whole water direct TOC measurement results are less than the sum of particulate and dissolved fractions in filtered water. The difference is statistically significant, so an adjustment to the whole water TOC should be made if the user is analyzing data from pre- and post-method change.

**OTHER ISSUES:**

Inter-organization agreement among mainstem laboratories for TOC calculated was high, based on CSSP data (AMQAW 1992). Even though both DOC and POC had low agreement, when added together the differences apparently disappeared.

**OTHER DOCUMENTATION:**

Analytical Methods and Quality Assurance Workgroup (AMQAW). 1992. Chesapeake Bay Coordinated Split Sample Program Annual Report, 1990-1991. CBP/TRS 76/92, Chesapeake Bay Program, Annapolis, MD.

**TITLE:** DISSOLVED ORGANIC CARBON  
**PARAMETER NAME (NEW):** DOC  
**PARAMETER NAME (OLD):** DOC  
**UNITS OF MEASURE:** mg/l as C  
**METHOD CODES:** See Methods Table

**GENERAL METHOD:**

The three mainstem laboratories used two different methods, using three different instruments. CBL and ODU used persulfate oxidation at 100 C, and did not preserve the samples in the field. CBL used an Oceanographic Instruments (OI) injection instrument, and ODU used an OI ampule instrument. VIMS used a Shimadzu high-temperature catalyst method, and preserved the sample in the field with hydrochloric acid.

**METHOD CHANGES:**

Measurements of DOC were discontinued in the Maryland and Virginia mainstem and Virginia tributary programs after September 1995. Because TOC is obtained by adding the particulate and dissolved carbon fractions after 1987, discontinuation of DOC also resulted in a discontinuation of the mainstem Bay TOC data record after 1995.

In Maryland, EPA Region 3 CRL used manual injection methods which were unreliable, and the data should not be used (See DAITS #18). CBL changed from OI ampule to OI injection on 3/1/87.

In Virginia, ODU analyzed DOC (and TOC until 12/87) for all ODU and VIMS stations until 7/90, when VIMS started DOC analyses for VIMS stations. The lab at ODU that analyzed DOC changed for VIMS stations in 1/88, and for ODU stations in 9/88, from Dr. Wolfenbarger's lab to Steve Sokolowski's lab (AMRL). There was no method change, but percent recoveries became much less variable. Before the lab change, DOC recoveries ranged from 50-186%, and their standard deviation was 24%. After the change, DOC recoveries ranged from 79-122%, and their standard deviation was only 8%.

**DAITS ISSUES:**

#018 - Manual injection carbon data. CRL used a manual injection method where the results depended on how forcefully the sample was injected. Analytical Methods and Quality Assurance Workgroup (AMQAW) members recommended against using any TOC or DOC results for Maryland mainstem stations before 5/15/85.

#021 - Dissolved organic carbon method comparisons. Salley et al. (1992) summarizes comparisons at VIMS stations; other comparisons at a wider range of salinities are ongoing.

**OTHER ISSUES:**

Inter-organization agreement among mainstem laboratories was low, based on CSSP data (AMQAW 1992). Results were significantly higher from VIMS; the Shimadzu method apparently recovers more DOC than other methods.

OTHER DOCUMENTATION:

AMQAW. 1992. Chesapeake Bay Coordinated Split Sample Program Annual Report, 1990-1991. CBP/TRS 76/92, Chesapeake Bay Program, Annapolis, MD.

Salley, B., et al. 1992. A comparison of two methods of measuring dissolved organic carbon. Special Scientific Report #128, Virginia Institute of Marine Science (VIMS), Gloucester Point, VA.



**TITLE:** PARTICULATE ORGANIC CARBON and PARTICULATE CARBON  
**PARAMETER NAME (NEW):** PC  
**PARAMETER NAME (OLD):** POC  
**UNITS OF MEASURE:** mg/l as C  
**METHOD CODES:** See Methods Table

**GENERAL METHOD:**

Calculated:  $POC = TOC - DOC$ . The name assumes all of the particulate carbon is the organic form.

Direct: All mainstem laboratories determine from a filter combusted at 975-1050 C using an elemental analyzer. The results may include some inorganic carbon, thus the more general parameter name, PC.

**METHOD CHANGES:**

Major method changes have occurred. The change from calculated POC to PC direct was made to avoid having to calculate any parameters by subtraction, since calculations by subtraction were shown to be less accurate and often yielded negative values (see D'Elia et al. 1987, although it does not discuss carbon methods). The change to measuring dissolved and particulate fractions separately and directly was made in October 1987 for the mainstem monitoring programs and later, at different times for the several tributary monitoring programs. See Tables 3a and 3b in Appendix 3 for a chronology of laboratory methods and detection limits.

**DAITS ISSUES:**

#010 - Summarizes method comparison data available to document comparability of old and new POC/PC methods.

#021 - Carbon analysis QA problems. Method changes cause uncertainty when trying to combine data from many labs for analysis.

#023 - Effects of filter rinsing on POC/PON results.

**OTHER ISSUES:**

Inter-organization agreement among mainstem laboratories was low, based on CSSP data (AMQAW 1992). Results were significantly higher from CBL than at VIMS or ODU. This was apparently due to filter rinsing at VIMS, which caused loss of POC, and positive pressure filtration at ODU. In 1992, VIMS stopped rinsing, and ODU switched to vacuum filtration, which should increase agreement. VIMS and ODU also use a different elemental analyzer from the one used by CBL.

**OTHER DOCUMENTATION:**

Analytical Methods and Quality Assurance Workgroup (AMQAW). 1992. Chesapeake Bay Coordinated Split Sample Program Annual Report, 1990-1991. CBP/TRS 76/92, Chesapeake Bay Program, Annapolis, MD.

D'Elia, C. et al. 1987. Nitrogen and phosphorus determinations in estuarine waters: a comparison of methods used in Chesapeake Bay Monitoring. CBP/TRS 7/87, Chesapeake Bay Program, Annapolis, MD.

**TITLE:** SILICA, FILTERED  
**PARAMETER NAME:** SI  
**UNITS OF MEASURE:** mg/l as SI  
**METHOD CODES:** See Methods Table

**GENERAL METHOD:**

Determined with autoanalyzer using reduction of silicomolybdate to molybdenum blue with ascorbic acid.

**METHOD CHANGES:**

None.

**DAITS ISSUES:**

#032 - Virginia SI and NO23 data. SI was missing in the 1992-93 data, from confusion about calculated vs measured parameter values. This issue has been rectified, although for the 1992-93 period there may be an abnormally high number of missing values.

**OTHER ISSUES:**

Inter-organization agreement was fairly low at mainstem laboratories, based on CSSP data (AMQAW 1992). CBL had significantly lower results than VIMS or ODU; the differences were larger than the analytical precision in 5 of 9 cruises analyzed. Possible causes of these differences are under investigation.

**OTHER DOCUMENTATION:**

Analytical Methods and Quality Assurance Workgroup (AMQAW). 1992. Chesapeake Bay Coordinated Split Sample Program Annual Report, 1990-1991. CBP/TRS 76/92, Chesapeake Bay Program, Annapolis, MD.

**TITLE:** TOTAL SUSPENDED SOLIDS  
**PARAMETER NAME (NEW):** TSS  
**PARAMETER NAME (OLD):** TSS  
**UNITS OF MEASURE:** mg/l  
**METHOD CODES:** See Methods Table

**GENERAL METHOD:**

A known volume of sample is filtered through a pre-weighed filter. The filter is dried at 103-105 C, re-weighed, and the dry weight of TSS is calculated by subtraction (EPA method 160.2). This is converted to mg/l TSS by dividing the weight by the filtered water volume.

**METHOD CHANGES:**

No major documented method changes. See Other Issues for step trend in MD tribs due to change in laboratory. CBL has proposed a change in filter pore size from 0.7 µm to 1.5 µm. (April 2009).

**DAITS ISSUES:**

#001 - Data censoring criteria. High TSS values in bottom samples are sometimes used as an indicator that the sample pump hit the bottom, which stirred up bottom sediments. MD mainstem data sometimes include the Analysis Problem Code "TS" or "SS" to indicate TSS data deleted for this reason; particulate nutrient parameters (PP, PC, PN) may also be deleted.

#045 - Investigation of TSS Step Trend at Virginia mainstem stations. A downward step-trend in TSS revealed itself in early 1999 at stations originally sampled by VIMS and later, after 1995 by ODU. Showed 3 yrs after lab switchover. Cause is not known. No correction factor was established.

A problem with TSS data has appeared at MD tidal tributary stations which transitioned from DHMH to CBL in May 1998. At these stations, TSS exhibits a decreasing step trend with much reduced variability in the data due to CBL reporting the average of two pads. The DHMH lab reported results from only one pad. This is not the only problem. There are a myriad of problems that are difficult to figure out after the fact, but it appears that a fix of sorts could be estimated from salinity data. There has been no resolution to this problem to date. A DAITS write-up is being drafted.

**OTHER ISSUES:**

Inter-organization agreement was fairly low at mainstem laboratories, based on CSSP data (AMQAW 1992). CBL had significantly lower results than VIMS or ODU; the differences were larger than the analytical precision in 4 of 7 cruises analyzed.

A habitat requirement for Submerged Aquatic Vegetation (SAV) growth has been established for TSS. April-October median surface values should be less than 15 mg/l baywide. See Batiuk et al. (1992) for details.

**OTHER DOCUMENTATION:**

Analytical Methods and Quality Assurance Workgroup (AMQAW). 1992. Chesapeake Bay

Coordinated Split Sample Program Annual Report, 1990-1991. CBP/TRS 76/92, Chesapeake Bay Program, Annapolis, MD.

Batiuk et al. 1992. Chesapeake Bay Submerged Aquatic Vegetation Habitat Requirements and Restoration Goals: A Technical Synthesis. CBP/TRS 52/92.

**TITLE:** CHLOROPHYLL *a* and PHEOPHYTIN  
(spectrophotometric)

**PARAMETER NAME (NEW):** CHLA and PHEO

**PARAMETER NAME (OLD):** CHLA and PHEA

**UNITS OF MEASURE:** ug/l

**METHOD CODES:** L01, L02, see Methods table

Chlorophyll is the green molecule in plant cells that carries out the bulk of energy fixation in photosynthesis and is used as an estimator of algal biomass. Chlorophyll is not a single molecule but a family of related molecules, designated chlorophyll *a*, *b*, *c*, and *d*. Chlorophyll *a* is the molecule found in all plant cells and its concentration is what is typically reported from the chlorophyll analysis and the value maintained in the CIMS water quality database. Chlorophylls *b* and *c* are common in fresh and estuarine waters, but chlorophyll *d* is found only in marine red algae. Users can derive for themselves the concentrations of the *b*- and *c*-molecular forms from the spectrophotometric readings in the Optical Density database. (See Defining Data Selection Criteria: Types of Data: Optical Density Data).

Pheophytin is the colored degradation product of these pigments. When algal chlorophyll degrades, it forms a series of degradation products depending on what part of the molecule is affected. The first step is either the loss of magnesium from the center of the molecule or the loss of the phytol tail. The former pathway results in the formation of the pheophytin molecule.

**GENERAL METHOD:**

Chlorophyll and pheophytin are determined using acetone extraction from a ground filter and calculated from Optical Density (OD) readings at several wavelengths using a spectrophotometer.

The chlorophyll value maintained in the CIMS database is monochromatic, corrected chlorophyll<sub>a</sub>, calculated according to the ASTM protocol:

$$\text{CHLA} = 26.7 [(OD_{664b} - OD_{750b}) - (OD_{665a} - OD_{750a})] * K$$

$$\text{PHEO} = 26.7 [1.7 (OD_{665a} - OD_{750a}) - (OD_{664b} - OD_{750b})] * K$$

where K = (extract volume/sample volume \* light path). Readings at additional wavelengths may be submitted and, where available, allow chlorophyll calculations using other protocols, e.g., Standard Methods protocol for monochromatic chlorophyll *a*:

$$\text{CHLA} = 26.73 [(OD_{663b} - OD_{750b}) - (OD_{665a} - OD_{750a})] * K$$

$$\text{PHEO} = 26.73 [1.7 (OD_{665a} - OD_{750a}) - (OD_{663b} - OD_{750b})] * K.$$

Equations for trichromatic chlorophyll molecules are as follows:

**ASTM:**

$$\text{CHL}_a = [11.85(OD_{664b}) - 1.50(OD_{647b}) - 0.08(OD_{630b})] * K$$

$$\text{CHL}_b = [21.03(OD_{647b}) - 5.43(OD_{664b}) - 2.66(OD_{630b})] * K$$

$$\text{CHL\_c} = [24.52(\text{OD630b}) - 1.67(\text{OD664b}) - 7.60(\text{OD647b})]*K$$

#### Standard Methods:

$$\text{CHL\_a} = [11.64(\text{OD663b}) - 2.16(\text{OD645b}) - 0.10(\text{OD630b})]*K$$

$$\text{CHL\_b} = [20.97(\text{OD645b}) - 3.94(\text{OD663b}) - 3.66(\text{OD630b})]*K$$

$$\text{CHL\_c} = [54.22(\text{OD630b}) - 14.81(\text{OD645b}) - 5.53(\text{OD663b})]*K$$

#### METHOD CHANGES:

Maryland: Maryland labs which measure phyto-pigments with spectrophotometry (MDHMH does; Chesapeake Biological Laboratory does not) submit OD readings and supporting data to calculate monochromatic, corrected chlorophyll\_a and trichromatic chlorophyll using both ASTM and Standard Methods equations. This is true with minor exceptions for both main Bay and tributary monitoring programs. Exceptions are: in the 1998 mainstem program, an essential OD reading (OD645b) for the Standard Method calculation was dropped, but was resumed the following year. In the beginning years of the tributary monitoring program (1984-1985), OD readings for the Standard Method calculations were taken, but not the complete set of wavelengths for the ASTM method (OD647b, OD664b omitted). These were added in 1986.

Virginia: Virginia labs (AMRL/Old Dominion University, VCU and VADCLS) all submit only the OD readings for wavelengths required to calculate the chlorophyll species using ASTM equations. This is true for both main Bay and tributary programs. Optical density readings for the mainstem stations sampled by VIMS from 1984 through 1995 are not available in the optical density data tables, although the calculated chlorophyll and pheophytin concentrations using ASTM equations are available for those stations in the water quality data tables. Similarly, calculated concentrations of chlorophyll and pheophytin are available for Virginia tributary stations in the early years of their respective programs, but the OD readings are not consistently available in the Optical Density tables until 1998.

ODU collected and submitted OD readings at 480 and 510 nm wavelengths for many years, through early 1999 to provide additional pigment information as part of food quality studies of phytoplankton for zooplankton. The OD readings available online in CIMS are only those from 1998-99. The earlier data may be available through ODU. See DAITS #035.

#### DAITS ISSUES:

#028 - Problematic chlorophyll values in Virginia tributary data sets

#029 - Discrepancy in Maryland data, between WQ and Biomonitoring discrete measurements of chlorophyll (affected parameters are CHLA and PHEA (=PHEO)).

#035 - VA Optical Density Data Submission (regarding maintenance of the 480 and 510 nm wavelengths submitted by ODU in the CIMS database).

#037 - Chlorophyll Method Comparison and Revision

#### OTHER ISSUES:

In the water quality database where CHLA and PHEO values are reported, there is a practice exercised inconsistently among data providers of deleting chlorophyll data whenever PHEO > CHLA, even when there is no indication of sample handling or measurement error. In Maryland data, at least, such censored data are usually flagged by using PROBLEM code = 'V'. Many analysts recommend such data not be censored, assuming the differences are small and due to the small measurement error inherent in all chlorophyll measurements.

A habitat requirement for Submerged Aquatic Vegetation (SAV) growth has been established for CHLA. April-October median surface values should be less than 15 ug/l baywide. See Batiuk et al. (1992) for details. Since then, water quality criteria based on other biological endpoints (for chlorophyll, dissolved oxygen and water clarity) have overshadowed this habitat restoration goal. See EPA (2007) for details.

#### OTHER DOCUMENTATION:

Analytical Methods and Quality Assurance Workgroup (AMQAW). 1992. Chesapeake Bay Coordinated Split Sample Program Annual Report, 1990-1991. CBP/TRS 76/92, Chesapeake Bay Program, Annapolis, MD.

Batiuk et al. 1992. Chesapeake Bay Submerged Aquatic Vegetation Habitat Requirements and Restoration Goals: A Technical Synthesis. CBP/TRS 52/92.

D'Elia et al. 1986. Methodological comparisons for nitrogen and chlorophyll determinations in estuarine water samples. University of Maryland, Center for Estuarine and Environmental Studies, Publication UMCEES-CBL-86-55.:

D'Elia, C. et al. 1987. Nitrogen and phosphorus determinations in estuarine waters: a comparison of methods used in Chesapeake Bay Monitoring. CBP/TRS 7/87, Chesapeake Bay Program, Annapolis, MD.

EPA, 2007. Ambient Water Quality Criteria for Dissolved Oxygen, Water Clarity and Chlorophyll *a* for the Chesapeake Bay and Its Tidal Tributaries. 2007 Chlorophyll Criteria Addendum. EPA 903-R-07-005; CBP/TRS 288/07.



**TITLE: CHLOROPHYLL<sub>α</sub> AND PHEOPHYTIN,  
(fluorometric)**

**PARAMETER NAME (NEW): CHLA and PHEO**

**PARAMETER NAME (OLD): CHLAF and PHEAF**

**UNITS OF MEASURE: ug/l**

**METHOD CODES: L03 - See Methods Table**

**GENERAL METHOD:**

Fluorometric chlorophyll measurements can be made both in the field and in the laboratory. Field fluorometry allows *in-situ* measurements of chlorophyll in water passing through the instrument without filtration while the sampling vessel is stopped or underway. The *in-situ* measurements taken on station from surface to bottom provide a vertical profile, and near-surface samples collected with a hull pump while the boat is underway provide horizontal chlorophyll profiles. The flow-through mode does not allow for acidification and thus only the chlorophyll a concentrations are available in the database for these profiles. In the laboratory context, however, the instrument can be used to measure chlorophyll from a filter extraction and, after acidification, pheophytin as well.

For *in-situ* measurements, chlorophyll molecules fluoresce at specific wavelengths of light. At these wavelengths, the fluorescence of chlorophyll is proportional to ambient chlorophyll concentration. A submersible sampling pump or hull pump is used to pump ambient water through a flow-through cuvette fitted to the fluorometer to provide *in vivo* measurement of chlorophyll concentrations.

The fluorometric method is used for the SWM calibration samples and uses the extractive acidification method. The fluorometer is equipped with a daylight white lamp, 340-500 nm excitation filter, and > 665 nm emission filter. The *in-situ* fluorometric measurements are calibrated against spectrophotometric chlorophyll results.

**METHOD CHANGES:**

ODU: ODU started collecting fluorometry in December of 1990. An analog Model 10-005R Turner Fluorometer was used. Since April 1997, a Digital Turner Model AU-10 Fluorometer has been used for the horizontal fluorometry. This fluorometer was used for the vertical profile from April 1997 to October 2005. Since November 2005, vertical fluorometry has been collected using a Wet Star Fluorometric sensor.

**DAITS ISSUES:**

#027 - Fluorometric chlorophyll data structure. The best way to store the vertical and horizontal profiles of fluorometric CHLA in the CBP database is discussed.

**OTHER ISSUES:**

The chlorophyll habitat requirement for Submerged Aquatic Vegetation (SAV) growth and chlorophyll criteria for the Bay and tributaries can also be applied to fluorometric measures of chlorophyll. See Batiuk et al. (1992) and EPA (2007) for details.

Fluorometry data from ODU is submitted to CBP for both vertical and horizontal fluorometry.

OTHER DOCUMENTATION:

Batiuk et al. 1992. Chesapeake Bay Submerged Aquatic Vegetation Habitat Requirements and Restoration Goals: A Technical Synthesis. CBP/TRS 52/92.

D'Elia et al. 1986. Methodological comparisons for nitrogen and chlorophyll determinations in estuarine water samples. University of Maryland, Center for Estuarine and Environmental Studies, Publication UMCEES-CBL-86-55.

EPA, 2007. Ambient Water Quality Criteria for Dissolved Oxygen, Water Clarity and Chlorophyll *a* for the Chesapeake Bay and Its Tidal Tributaries. 2007 Chlorophyll Criteria Addendum. EPA 903-R-07-005; CBP/TRS 288/07.

## OTHER PARAMETERS

Several other parameters record weather conditions and sea state during sampling. See table below. These are all character variables, except for air temperature, which is numeric. The defined, allowable character values are defined in the [Data Dictionary](#). Their use varies among different sampling organizations and at different times.

<b>TITLE</b>	<b>PARAMETER NAME (NEW)</b>	<b>PARAMETER NAME (OLD)</b>	<b>UNITS OF MEASURE</b>
Air Temperature	AIR_TEMP	ATEMP	degrees Celsius
Cloud Cover	CLOUD_COVER	CLOUD	n/a
Tidal stage	TIDE_STAGE	TIDE	n/a
Wave Height	WAVE_HEIGHT	WAVHGT	n/a
Wind Direction	WIND_DIRECTION	WINDIR	n/a
Wind Speed	WIND_SPEED	WINSPD	n/a

### DAITS ISSUES:

#014 – Reporting of Wind speed data – describes inconsistencies among data submitters.

## **Appendix 1**

### **Station Lists for Programs Contributing Data to the CIMS Water Quality Database**

The station tables below are for programs whose data are most frequently requested. They are subsets of the full list of stations in the CIMS water quality database, which also includes the stations for other programs and groups that submit water quality data to CIMS. Additional station-related information (i.e., other variables) available through CIMS can be seen in Tables 1 and 2 of the Guide.

Table A1-1. Stations monitored in conjunction with the CBP Water Quality Monitoring Program conducted in tidal waters of the Chesapeake Bay and tributaries (PROGRAM='WQMP', PROJECT=MAIN, TRIB respectively). Some of the stations also appear in other station lists below, e.g., the Elizabeth River stations.

**Table A1-1**

STATION	ORIGINAL STATION	WATERBODY	CBSEG_2003	STATION DEPTH <sup>1</sup>	SAMPLE NUMBR <sup>2</sup>	PROJECT	AGENCY	SOURCE	NOTES
CB1.0	SUS0109	SUSQUEHANNA R	SUSNT			TRIB	MDDNR	MDDNR	9,10
CB1.1	MCB1.1	CHES BAY	CB1TF	6.1	2	MAIN	MDDNR	MDDNR	
CB2.1	MCB2.1	CHES BAY	CB1TF	6.3	2	MAIN/TRIB	MDDNR	MDDNR	
CB2.2	MCB2.2	CHES BAY	CB2OH	12.4	4	MAIN	MDDNR	MDDNR	
CB3.1	MCB3.1	CHES BAY	CB2OH	13.0	4	MAIN	MDDNR	MDDNR	
CB3.2	MCB3.2	CHES BAY	CB3MH	12.1	4	MAIN	MDDNR	MDDNR	
CB3.3C	XHF1373	CHES BAY	CB3MH	24.3	4	MAIN/TRIB	MDDNR	MDDNR	9
CB3.3E	MCB3.3E	CHES BAY	CB3MH	8.3	2	MAIN	MDDNR	MDDNR	3, 4
CB3.3W	MCB3.3W	CHES BAY	CB3MH	9.0	2	MAIN	MDDNR	MDDNR	3, 4
CB4.1C	MCB4.1C	CHES BAY	CB4MH	32.2	4	MAIN	MDDNR	MDDNR	
CB4.1E	MCB4.1E	EASTERN BAY	CB4MH	23.6	4	MAIN	MDDNR	MDDNR	4
CB4.1W	MCB4.1W	CHES BAY	CB4MH	9.3	2	MAIN	MDDNR	MDDNR	3
CB4.2C	MCB4.2C	CHES BAY	CB4MH	27.2	4	MAIN	MDDNR	MDDNR	
CB4.2E	MCB4.2E	CHES BAY	CB4MH	9.5	2	MAIN	MDDNR	MDDNR	3, 4
CB4.2W	MCB4.2W	CHES BAY	CB4MH	9.4	2	MAIN	MDDNR	MDDNR	3, 4
CB4.3C	MCB4.3C	CHES BAY	CB4MH	26.9	4	MAIN	MDDNR	MDDNR	
CB4.3E	MCB4.3E	CHES BAY	CB4MH	22.4	4	MAIN	MDDNR	MDDNR	
CB4.3W	MCB4.3W	CHES BAY	CB4MH	9.8	2	MAIN	MDDNR	MDDNR	3
CB4.4	MCB4.4	CHES BAY	CB4MH	30.3	4	MAIN	MDDNR	MDDNR	
CB5.1	MCB5.1	CHES BAY	CB5MH	34.1/17.1	4	MAIN/TRIB	MDDNR	MDDNR	
CB5.1W	XCF9575	CHES BAY	CB5MH	9.1	4	TRIB	MDDNR	MDDNR	
CB5.2	MCB5.2	CHES BAY	CB5MH	30.6	4	MAIN	MDDNR	MDDNR	
CB5.3	MCB5.3	CHES BAY	CB5MH	26.9	4	MAIN	MDDNR	MDDNR	5
CB5.4	CB5.4	CHES BAY	CB5MH	31.1	4	MAIN	VADEQ	VIMS/ODU	6
CB5.4W	CB5.4W	CHES BAY	CB5MH	5.0	2	MAIN	VADEQ	VIMS/ODU	
CB5.5	CB5.5	CHES BAY	CB5MH	17.0	4	MAIN	VADEQ	VIMS/ODU	6
CB6.1	CB6.1	CHES BAY	CB6PH	12.5	4	MAIN	VADEQ	VIMS/ODU	6
CB6.2	CB6.2	CHES BAY	CB6PH	10.5	4	MAIN	VADEQ	VIMS/ODU	6
CB6.3	CB6.3	CHES BAY	CB6PH	11.3	4	MAIN	VADEQ	VIMS/ODU	6
CB6.4	8	CHES BAY	CB6PH	10.2	4	MAIN	VADEQ	ODU	7
CB7.1	CB7.1	CHES BAY	CB7PH	20.9	2	MAIN	VADEQ	VIMS/ODU	
CB7.1N	CB7.1N	CHES BAY	CB7PH	31.8/23.4	2	MAIN	VADEQ	VIMS/ODU	
CB7.1S	CB7.1S	CHES BAY	CB7PH	14.1	2	MAIN	VADEQ	VIMS/ODU	
CB7.2	CB7.2	CHES BAY	CB7PH	20.2	2	MAIN	VADEQ	VIMS/ODU	
CB7.2E	CB7.2E	CHES BAY	CB7PH	12.9	2	MAIN	VADEQ	VIMS/ODU	

Table A1-1

STATION	ORIGINAL STATION	WATERBODY	CBSEG 2003	STATION DEPTH <sup>1</sup>	SAMPLE NUMBR <sup>2</sup>	PROJECT	AGENCY	SOURCE	NOTES
CB7.3	6	CHES BAY	CB7PH	13.6	4	MAIN	VADEQ	ODU	7
CB7.3E	7	CHES BAY	CB7PH	17.8	2	MAIN	VADEQ	ODU	
CB7.4N	5	CHES BAY	CB7PH	12.6	2	MAIN	VADEQ	ODU	
EE3.5	EE3.2	CHES BAY	CB7PH	27.3/23.4	2	MAIN	VADEQ	VIMS/ODU	
CB7.4	4	CHES BAY	CB8PH	14.2	4	MAIN	VADEQ	ODU	8
CB8.1	2	CHES BAY	CB8PH	9.9	2	MAIN	VADEQ	ODU	
CB8.1E	3	CHES BAY	CB8PH	16.8	2	MAIN	VADEQ	ODU	
LE5.5A	LE5.5A	JAMES R	CB8PH	3.3	1	MAIN	VADEQ	ODU	12
LE5.5B	LE5.5B	JAMES R	CB8PH	2.1	1	MAIN	VADEQ	ODU	12
ET1.1	MET1.1	NORTHEAST R	NORTF	2.8	2	TRIB	MDDNR	MDDNR	
ET2.1	MET2.1	BACK CRK	C&DOH	13.0	2	TRIB	MDDNR	MDDNR	
ET2.2	MET2.2	BOHEMIA R	BOHOH	2.8	2	TRIB	MDDNR	MDDNR	
ET2.3	MET2.3	ELK R	ELKOH	12.5	2	TRIB	MDDNR	MDDNR	
ET3.1	MET3.1	SASSAFRAS R	SASOH	5.8	2	TRIB	MDDNR	MDDNR	
ET4.1	MET4.1	CHESTER R	CHSOH	5.4	2	TRIB	MDDNR	MDDNR	
ET4.2	MET4.2	CHESTER R	CHSMH	14	4	TRIB	MDDNR	MDDNR	
XGG8251	XGG8251	CHESTER R	CHSMH	5.5	2	TRIB	MDDNR	MDDNR	9
EE1.1	MEE1.1	EASTERN BAY	EASMH	12.6	4	TRIB	MDDNR	MDDNR	
ET5.0	CHO0626	CHOPTANK R	CHOTF	0		TRIB	MDDNR	MDDNR	9, 10
ET5.1	MET5.1	CHOPTANK R	CHOOH	6.5	2	TRIB	MDDNR	MDDNR	
ET5.2	MET5.2	CHOPTANK R	CHOMH 2	11.9	4	TRIB	MDDNR	MDDNR	
EE2.1	MEE2.1	CHOPTANK R	CHOMH 1	7.8	4	TRIB	MDDNR	MDDNR	
EE2.2	MEE2.2	LITTLE CHOPTANK	LCHMH	13	2	TRIB	MDDNR	MDDNR	
EE3.0	MEE3.0	FISHING BAY	FSBMH	7.3	2	TRIB	MDDNR	MDDNR	
ET6.1	MET6.1	NANTICOKE R	NANTF	5.0	2	TRIB	MDDNR	MDDNR	
ET6.2	MET6.2	NANTICOKE R	NANMH	3.9	2	TRIB	MDDNR	MDDNR	
ET7.1	MET7.1	WICOMICO R	WICMH	6.8	2	TRIB	MDDNR	MDDNR	
ET8.1	MET8.1	MANOKIN R	MANMH	5.3	2	TRIB	MDDNR	MDDNR	
ET9.1	MET9.1	BIG ANNEMESSEX	BIGMH	4.9	2	TRIB	MDDNR	MDDNR	
ET10.1	MET10.1	POCOMOKE R	POCTF	5.8	2	TRIB	MDDNR	MDDNR	
EE3.3	MEE3.3	POCOMOKE SND	POCMH	3.9	2	TRIB	MDDNR	MDDNR	
EE3.4	EE3.1	POCOMOKE SND	POCMH	4.9	2	MAIN	VADEQ	VIMS/ODU	
EE3.1	MEE3.1	TANGIER SND	TANMH	13.1	4	TRIB	MDDNR	MDDNR	
EE3.2	MEE3.2	TANGIER SND	TANMH	27.1	4	TRIB	MDDNR	MDDNR	
WT1.1	MWT1.1	BUSH R	BSHOH	2.3	2	TRIB	MDDNR	MDDNR	
WT2.1	MWT2.1	GUNPOWDER R	GUNOH	1.9	2	TRIB	MDDNR	MDDNR	
WT3.1	MWT3.1	MIDDLE R	MIDOH	3.4	2	TRIB	MDDNR	MDDNR	
WT4.1	MWT4.1	BACK R (MD)	BACOH	1.7	2	TRIB	MDDNR	MDDNR	
WT5.1	MWT5.1	PATAPSCO R	PATMH	15.3	4	TRIB	MDDNR	MDDNR	
WT6.1	MWT6.1	MAGOTHY R	MAGMH	5.6	2	TRIB	MDDNR	MDDNR	
WT7.1	MWT7.1	SEVERN R	SEVMH	9.2	2	TRIB	MDDNR	MDDNR	
WT8.1	MWT8.1	SOUTH R	SOUTHMH	8.8	2	TRIB	MDDNR	MDDNR	
WT8.2	MWT8.2	RHODE R	RHDMH	2.6	2	TRIB	MDDNR	MDDNR	
WT8.3	MWT8.3	WEST R	WSTMH	3.4	2	TRIB	MDDNR	MDDNR	

**Table A1-1**

STATION	ORIGINAL STATION	WATERBODY	CBSEG 2003	STATION DEPTH <sup>1</sup>	SAMPLE NUMBR <sup>2</sup>	PROJECT	AGENCY	SOURCE	NOTES
TF1.0	PXT0603	PATUXENT R	PAXTF	2.3		TRIB	MDDNR	MDDNR	9, 10
TF1.3	PXT0494	PATUXENT R	PAXTF	2.9	1	TRIB	MDDNR	MDDNR	
TF1.4	PXT0456	PATUXENT R	PAXTF	2.0	1	TRIB	MDDNR	MDDNR	
TF1.5	PXT0402	PATUXENT R	PAXTF	10.6	4	TRIB	MDDNR	MDDNR	
TF1.2	WXT0045	PATUXENT R	WBRTF	1.9	1	TRIB	MDDNR	MDDNR	
WXT0001	WXT0001	WESTERN BRNCH	WBRTF	1.3	1	TRIB	MDDNR	MDDNR	
TF1.6	XED9490	PATUXENT R	PAXOH	6.2	3	TRIB	MDDNR	MDDNR	
TF1.7	XED4892	PATUXENT R	PAXOH	3.0	2	TRIB	MDDNR	MDDNR	
LE1.1	XDE5339	PATUXENT R	PAXMH	12.1	4	TRIB	MDDNR	MDDNR	
LE1.2	XDE2792	PATUXENT R	PAXMH	17.1	4	TRIB	MDDNR	MDDNR	
LE1.3	XDF0407	PATUXENT R	PAXMH	23.4	4	TRIB	MDDNR	MDDNR	
LE1.4	XCF8747	PATUXENT R	PAXMH	15.4	4	TRIB	MDDNR	MDDNR	
RET1.1	XDE9401	PATUXENT R	PAXMH	11.2	4	TRIB	MDDNR	MDDNR	
TF2.1	XFB2470	POTOMAC R	POTTF	19	2	TRIB	MDDNR	MDDNR	
TF2.2	XFB1433	POTOMAC R	POTTF	8.3	2	TRIB	MDDNR	MDDNR	
TF2.3	XEA6596	POTOMAC R	POTTF	12.8	2	TRIB	MDDNR	MDDNR	
TF2.4	XEA1840	POTOMAC R	POTTF	8.9	2	TRIB	MDDNR	MDDNR	
PIS0033	PIS0033	PISCATAWAY CRK	PISTF	0	1	TRIB	MDDNR	MDDNR	
XFB1986	XFB1986	PISCATAWAY CRK	PISTF	1.5		TRIB	MDDNR	MDDNR	
MAT0016	MAT0016	MATTAWOMAN CR	MATTF	6.9	1	TRIB	MDDNR	MDDNR	
MAT0078	MAT0078	MATTAWOMAN CR	MATTF		1	TRIB	MDDNR	MDDNR	
RET2.1	XDA4238	POTOMAC R	POTOH	7.4	2	TRIB	MDDNR	MDDNR	
RET2.2	XDA1177	POTOMAC R	POTOH	10.1	2	TRIB	MDDNR	MDDNR	
RET2.3	XDB3321	POTOMAC R	POTOH	9.1	2	TRIB	MDDNR	MDDNR	
LE2.2	MLE2.2	POTOMAC R	POTMH	12.0	4	TRIB	MDDNR	MDDNR	
LE2.3	MLE2.3	POTOMAC R	POTMH	20.1	4	MAIN	MDDNR	MDDNR	
RET2.4	XDC1706	POTOMAC R	POTMH	15.8	4	TRIB	MDDNR	MDDNR	
TF3.0		RAPPAHANNOCK	RPPTF			NTID /TRIB	VADEQ / USGS	USGS	10
TF3.0		RAPPAHANNOCK	RPPTF			TRIB	VADEQ	VADEQ/NRO/PRO	10
TF3.1A	TF3.1A	RAPPAHANNOCK	RPPTF	3.2	2	TRIB	VADEQ	VADEQ/NRO	
TF3.1B	TF3.1B	RAPPAHANNOCK	RPPTF	3.5	2	TRIB	VADEQ	VADEQ/NRO/PRO	
TF3.1C	TF3.1C	RAPPAHANNOCK	RPPTF	4.7	2	TRIB	VADEQ	VADEQ/NRO	
TF3.1D	TF3.1D	RAPPAHANNOCK	RPPTF	3.1	2	TRIB	VADEQ	VADEQ/NRO	
TF3.1E	TF3.1E	RAPPAHANNOCK	RPPTF	3.6	2	TRIB	VADEQ	VADEQ/NRO/PRO	
TF3.2	TF3.2	RAPPAHANNOCK	RPPTF	6.6	2	TRIB	VADEQ	VADEQ/NRO/PRO	
TF3.2A	TF3.2A	RAPPAHANNOCK	RPPTF	5.7	2	TRIB	VADEQ	VADEQ/PRO	
TF3.3	TF3.3	RAPPAHANNOCK	RPPHOH	7.0	2	TRIB	VADEQ	VADEQ/PRO/TRO	
TF3.3	TF3.3	RAPPAHANNOCK	RPPHOH		2	TRIB	VADEQ	VADEQ/TRO	
LE3.1	LE3.1	RAPPAHANNOCK	RPPMH	6.5	2	TRIB	VADEQ	VADEQ/TRO	
LE3.2	LE3.2	RAPPAHANNOCK	RPPMH	14.4	2	TRIB	VADEQ	VADEQ/TRO	
LE3.2N	LE3.2N	RAPPAHANNOCK	RPPMH		1	TRIB	VADEQ	VADEQ/TRO	12
LE3.2S	LE3.2S	RAPPAHANNOCK	RPPMH		1	TRIB	VADEQ	VADEQ/TRO	12

Table A1-1

STATION	ORIGINAL STATION	WATERBODY	CBSEG 2003	STATION DEPTH <sup>1</sup>	SAMPLE NUMBR <sup>2</sup>	PROJECT	AGENCY	SOURCE	NOTES
LE3.4	LE3.4	RAPPAHANNOCK	RPPMH	13.3	2	TRIB	VADEQ	VADEQ/TRO	
LE3.6	LE3.6	RAPPAHANNOCK	RPPMH	9.9	2	MAIN	VADEQ	VIMS/ODU	
LE3.6N	LE3.6N	RAPPAHANNOCK	RPPMH	3.8	1	MAIN	VADEQ	VIMS	12
LE3.6S	LE3.6S	RAPPAHANNOCK	RPPMH	4.1	1	MAIN	VADEQ	VIMS	12
RET3.1	RET3.1	RAPPAHANNOCK	RPPMH	5.7	2	TRIB	VADEQ	VADEQ/PRO	
RET3.1N	RET3.1N	RAPPAHANNOCK	RPPMH		1	TRIB	VADEQ	VADEQ/PRO	12
RET3.1S	RET3.1S	RAPPAHANNOCK	RPPMH		1	TRIB	VADEQ	VADEQ/PRO	12
RET3.2	RET3.2	RAPPAHANNOCK	RPPMH	4.8	2	TRIB	VADEQ	VADEQ/PRO/ TRO	
LE3.3	LE3.3	CORROTOMAN	CRRMH	5.2	2	TRIB	VADEQ	VADEQ/TRO	
LE3.7	LE3.7	PIANKATANK R	PIAMH	7.1	2	MAIN	VADEQ	VIMS/ODU	
TF4.0M		MATTAPONI R	MPNTF			NTID/TRIB	VADEQ/ USGS	USGS	10
TF4.0M		MATTAPONI R	MPNTF	1.0		TRIB	VADEQ	VADEQ/PRO	10
TF4.4	TF4.4	MATTAPONI R	MPNTF	3.1	2	TRIB	VADEQ	VADEQ/PRO	
TF4.4A	TF4.4A	MATTAPONI R	MPNTF	6.4	2	TRIB	VADEQ	VADEQ/PRO	
RET4.2	RET4.2	MATTAPONI R	MPNOH	13.0	2	TRIB	VADEQ	VADEQ/PRO/ TRO	
TF4.0P		PAMUNKEY R	PMKTF			NTID/TRIB	VADEQ/ USGS	USGS	10
TF4.0P		PAMUNKEY R	PMKTF	1.0		TRIB	VADEQ	VADEQ/PRO	10
TF4.1A	TF4.1A	PAMUNKEY R	PMKTF	5.4	2	TRIB	VADEQ	VADEQ/PRO	
TF4.2	TF4.2	PAMUNKEY R	PMKTF	6.7	2	TRIB	VADEQ	VADEQ/PRO	
RET4.1	RET4.1	PAMUNKEY R	PMKOH	5.4	2	TRIB	VADEQ	VADEQ/TRO	
LE4.1	LE4.1	YORK R	YRKMH	8.9	2	TRIB	VADEQ	VADEQ/TRO	
RET4.3	RET4.3	YORK R	YRKMH	5.5	2	TRIB	VADEQ	VADEQ/TRO	
RET4.3N	RET4.3N	YORK R	YRKMH		1	TRIB	VADEQ	VADEQ/TRO	12
RET4.3S	RET4.3S	YORK R	YRKMH		1	TRIB	VADEQ	VADEQ/TRO	12
LE4.2	LE4.2	YORK R	YRKPH	13.6	2	TRIB	VADEQ	VADEQ/TRO	
LE4.2N	LE4.2N	YORK R	YRKPH		1	TRIB	VADEQ	VADEQ/TRO	12
LE4.2S	LE4.2S	YORK R	YRKPH		1	TRIB	VADEQ	VADEQ/TRO	12
LE4.3	LE4.3	YORK R	YRKPH	15.7	2	TRIB	VADEQ	VADEQ/TRO	
LE4.3N	LE4.3N	YORK R	YRKPH		1	TRIB	VADEQ	VADEQ/TRO	
LE4.3S	LE4.3S	YORK R	YRKPH		1	TRIB	VADEQ	VADEQ/TRO	
WE4.1	WE4.1	MOBJACK BAY	MOBPH	5.6	2	MAIN	VADEQ	VIMS/ODU	
WE4.2	WE4.2	YORK R	MOBPH	12.5	2	MAIN	VADEQ	VIMS/ODU	
WE4.2N	WE4.2N	YORK R	MOBPH	4.0	1	MAIN	VADEQ	VIMS	
WE4.2S	WE4.2S	YORK R	MOBPH	3.4	1	MAIN	VADEQ	VIMS	
WE4.3	WE4.3	POQUOSON R	MOBPH	5.2	2	MAIN	VADEQ	VIMS/ODU	
WE4.4	WE4.4	BACK R (VA)	MOBPH	6.1	2	MAIN	VADEQ	VIMS/ODU	
TF5.0J		JAMES R	JMSTF			NTID/TRIB	VADEQ/ USGS	USGS	10
TF5.0J		JAMES R	JMSTF	1.0		TRIB	VADEQ	VADEQ/PRO	10
TF5.2	TF5.2	JAMES R	JMSTF	2.6	1	TRIB	VADEQ	VADEQ/PRO	
TF5.2A	TF5.2A	JAMES R	JMSTF	8.2	2	TRIB	VADEQ	VADEQ/PRO	
TF5.3	TF5.3	JAMES R	JMSTF	10.7	2	TRIB	VADEQ	VADEQ/PRO	
TF5.5	TF5.5	JAMES R	JMSTF	9.3	2	TRIB	VADEQ	VADEQ/PRO	
TF5.5A	TF5.5A	JAMES R	JMSTF	8.8	2	TRIB	VADEQ	VADEQ/PRO	



Table A1-1

STATION	ORIGINAL STATION	WATERBODY	CBSEG 2003	STATION DEPTH <sup>1</sup>	SAMPLE NUMBR <sup>2</sup>	PROJECT	AGENCY	SOURCE	NOTES
TF5.5AN	TF5.5AN	JAMES R	JMSTF	.	1	TRIB	VADEQ	VADEQ/PRO	12
TF5.5AS	TF5.5AS	JAMES R	JMSTF	.	1	TRIB	VADEQ	VADEQ/PRO	12
TF5.6	TF5.6	JAMES R	JMSTF	9.6	2	TRIB	VADEQ	VADEQ/PRO	
TF5.0A		APPOMATTOX R	APPTF	.		NTID/TRIB	VADEQ/ USGS	USGS	10
TF5.0A		APPOMATTOX R	APPTF	.		TRIB	VADEQ	VADEQ/PRO	10
TF5.4	TF5.4	APPOMATTOX R	APPTF	6.4	2	TRIB	VADEQ	VADEQ/PRO	
LE5.1	LE5.1	JAMES R	JMSOH	9.2	2	TRIB	VADEQ	VADEQ/TRO	
RET5.2	RET5.2	JAMES R	JMSOH	8.3	2	TRIB	VADEQ	VADEQ/PRO	
RET5.2	RET5.2	JAMES R	JMSOH	9.4	2	TRIB	VADEQ	VADEQ/TRO	
RET5.2N	RET5.2N	JAMES R	JMSOH	.	1	TRIB	VADEQ	VADEQ/TRO	12
RET5.2S	RET5.2S	JAMES R	JMSOH	.	1	TRIB	VADEQ	VADEQ/TRO	12
TF5.6A	TF5.6A	JAMES R	JMSOH	7.8	2	TRIB	VADEQ	VADEQ/PRO	
RET5.1	RET5.1	CHICKAHOMINY	CHKOH	2.1	1	TRIB	VADEQ	VADEQ/PRO	
RET5.1A	RET5.1A	CHICKAHOMINY	CHKOH	3.9	2	TRIB	VADEQ	VADEQ/PRO	
LE5.2	LE5.2	JAMES R	JMSMH	8.7	2	TRIB	VADEQ	VADEQ/TRO	
LE5.2N	LE5.2N	JAMES R	JMSMH	.	1	TRIB	VADEQ	VADEQ/TRO	12
LE5.2S	LE5.2S	JAMES R	JMSMH	.	1	TRIB	VADEQ	VADEQ/TRO	12
LE5.3	LE5.3	JAMES R	JMSMH	6.9	2	TRIB	VADEQ	VADEQ/TRO	
ELI1	ELI1	ELIZABETH R	JMSPH	8.0	2	TRIB	VADEQ	ODU	
LE5.4	LE5.4	JAMES R	JMSPH	15.8	2	TRIB	VADEQ	VADEQ/TRO	
LE5.5	1	JAMES R	JMSPH	21.3	2	MAIN	VADEQ	ODU	
LE5.5-W	LE5.5-W	JAMES R	JMSPH	7.6	2	MAIN	VADEQ	ODU	
WBB05	WBB05	ELIZABETH R	WBEMH	4.9	2	TRIB	VADEQ	VADEQ/TRO	
WBE1	WBE1	ELIZABETH R	WBEMH	4.4	2	TRIB	VADEQ	ODU	
SBA1	SBA1	ELIZABETH R	SBEMH	11.9	2	TRIB	VADEQ	ODU	
SBC1	SBC1	ELIZABETH R	SBEMH	11.4	2	TRIB	VADEQ	ODU	
SBD1	SBD1	ELIZABETH R	SBEMH	11.7	2	TRIB	VADEQ	ODU	
SBD4	SBD4	ELIZABETH R	SBEMH	3.1	2	TRIB	VADEQ	ODU	
SBE1	SBE1	ELIZABETH R	SBEMH	12.3	2	TRIB	VADEQ	ODU	
SBE2	SBE2	ELIZABETH R	SBEMH	12.2	2	TRIB	VADEQ	ODU	
SBE3	SBE3	ELIZABETH R	SBEMH	9.3	2	TRIB	VADEQ	ODU	
SBE4	SBE4	ELIZABETH R	SBEMH	9.8	2	TRIB	VADEQ	ODU	
SBE5	SBE5	ELIZABETH R	SBEMH	8.0	2	TRIB	VADEQ	ODU	
EBB01		ELIZABETH R	EBEMH	6.9	2	TRIB	VADEQ	VADEQ/TRO	
EBE1	EBE1	ELIZABETH R	EBEMH	8.6	2	TRIB	VADEQ	ODU	
EBE1-E		ELIZABETH R	EBEMH	8.3	2	TRIB	VADEQ	ODU	
EBE2	EBE2	ELIZABETH R	EBEMH	9.3	2	TRIB	VADEQ	ODU	
LAF1	LAF1	ELIZABETH R	LAFMH	5.8	2	TRIB	VADEQ	ODU	
LFA01	LFA01	ELIZABETH R	LAFMH	4.1	2	TRIB	VADEQ	VADEQ/TRO	
LFB01	LFB01	ELIZABETH R	LAFMH	4.2	2	TRIB	VADEQ	VADEQ/TRO	
ELD01	ELD01	ELIZABETH R	ELIPH	6.7	2	TRIB	VADEQ	VADEQ/TRO	
ELE01	ELE01	ELIZABETH R	ELIPH	10.4	2	TRIB	VADEQ	VADEQ/TRO	
ELI2	ELI2	ELIZABETH R	ELIPH	13.3	2	TRIB	VADEQ	ODU	
ELI3	ELI3	ELIZABETH R	ELIPH	12.8	2	TRIB	VADEQ	ODU	

**Table A1-1**

STATION	ORIGINAL STATION	WATERBODY	CBSEG 2003	STATION DEPTH <sup>1</sup>	SAMPLE NUMBR <sup>2</sup>	PROJECT	AGENCY	SOURCE	NOTES
LE5.6	LE5.6	ELIZABETH R	ELIPH	15.1	2	TRIB	VADEQ	VADEQ/TRO	11

- 1 STATION DEPTH (meters) is mean total depth using 1985-2005 monitoring data.
- 2 SAMPLE NUMBR represents the number of water samples for laboratory analysis collected each cruise at that station. Some stations are considered "pycnocline stations" and have four samples (S, AP, BP, B) collected, others have only two samples collected (S,B). See details for LAYER and PYCNOCLINE in Section IV.
- 3 Stations, by design, not sampled during "winter" after 1988. At first, dropped cruises included November through first March cruise, later extended to second September and October cruises. Other stations, usually shallower, freshwater stations were frequently dropped for one or more cruises in winter due to ice or weather conditions.
- 4 CB3.3E, CB3.3W, CB4.1W, CB4.2E, CB4.2W, and CB4.3W had four nutrient samples collected until cruise BAY075.
- 5 Station CB5.3 was sampled by both Maryland and Virginia agencies from the start of the program through April, 1990. The Virginia (VIMS) data for station CB5.3 was removed from the database to avoid confusion due to co-located samples. They are available upon request. The station appears twice in the full station list, once for each state agency.
- 6 CB5.4, CB5.5, CB6.1, CB6.2, and CB6.3 had only two nutrient samples collected until cruise BAY013.
- 7 CB6.4 and CB7.3 had only two nutrient samples collected until BAY021.
- 8 CB7.4 had only two nutrient samples collected until cruise BAY019. From then until BAY050, four samples were always collected when a pycnocline was detected. After cruise BAY050 four samples were always collected.
- 9 Stations in both CBP tidal water quality monitoring and MD Core Trend station networks.
- 10 Stations at or near the major fall line monitoring sites; these may also be identified as River Input Monitoring (RIM) program stations.
- 11 Segment ELIMH, formerly containing station LE5.6, was a region with defined segment boundaries near the mouth of Elizabeth River originally thought to be mesohaline. The region was later determined to be predominantly polyhaline and joined with segment ELIPH. At present, there is no such segment.
- 12 These stations were added for enhanced monitoring in Virginia tributaries beginning in January 1994 and lasted about a year.

Table A1-2. Stations monitored by the District of Columbia Department of Health (DCDOH) including stations in the Potomac and Anacostia rivers, the Chesapeake and Ohio Canal, the Washington Ship Channel, and the Washington Tidal Basin (PROGRAM variable = 'WQMP').

**Table A1-2**

STATION	ORIGINAL STATION	WATERBODY	CBSEG_2003	STATION DEPTH <sup>1</sup>	PROJECT	AGENCY	SOURCE	NOTES
AAG01	AAG01	ANACOSTIA R	ANATF	.	TRIB	DCDOH	DCDOH	2 (1993); 3 (1996)
AAG02	AAG02	ANACOSTIA R	ANATF	.	TRIB	DCDOH	DCDOH	2 (1996); 3 (1998)
ANA01	ANA01	ANACOSTIA R	ANATF	.	TRIB	DCDOH	DCDOH	
ANA02	ANA02	ANACOSTIA R	ANATF	.	TRIB	DCDOH	DCDOH	(1997) 3
ANA03	ANA03	ANACOSTIA R	ANATF	.	TRIB	DCDOH	DCDOH	(1997) 3
ANA04	ANA04	ANACOSTIA R	ANATF	.	TRIB	DCDOH	DCDOH	(1997) 3
ANA05	ANA05	ANACOSTIA R	ANATF	.	TRIB	DCDOH	DCDOH	
ANA06	ANA06	ANACOSTIA R	ANATF	.	TRIB	DCDOH	DCDOH	(1997) 3
ANA07	ANA07	ANACOSTIA R	ANATF	.	TRIB	DCDOH	DCDOH	(1997) 3
ANA08	ANA08	ANACOSTIA R	ANATF	.	TRIB	DCDOH	DCDOH	
ANA09	ANA09	ANACOSTIA R	ANATF	.	TRIB	DCDOH	DCDOH	(1997) 3
ANA10	ANA10	ANACOSTIA R	ANATF	.	TRIB	DCDOH	DCDOH	(1997) 3
ANA11	ANA11	ANACOSTIA R	ANATF	.	TRIB	DCDOH	DCDOH	
ANA12	ANA12	ANACOSTIA R	ANATF	.	TRIB	DCDOH	DCDOH	(1997) 3
ANA13	ANA13	ANACOSTIA R	ANATF	.	TRIB	DCDOH	DCDOH	(1997) 3
ANA14	ANA14	ANACOSTIA R	ANATF	.	TRIB	DCDOH	DCDOH	
ANA15	ANA15	ANACOSTIA R	ANATF	.	TRIB	DCDOH	DCDOH	(1997) 3
ANA16	ANA16	ANACOSTIA R	ANATF	.	TRIB	DCDOH	DCDOH	(1997) 3
ANA17	ANA17	ANACOSTIA R	ANATF	.	TRIB	DCDOH	DCDOH	(1997) 3
ANA18	ANA18	ANACOSTIA R	ANATF	.	TRIB	DCDOH	DCDOH	(1997) 3
ANA19	ANA19	ANACOSTIA R	ANATF	.	TRIB	DCDOH	DCDOH	
ANA20	ANA20	ANACOSTIA R	ANATF	.	TRIB	DCDOH	DCDOH	(1997) 3
ANA21	ANA21	ANACOSTIA R	ANATF	.	TRIB	DCDOH	DCDOH	
ANA22	ANA22	ANACOSTIA R	ANATF	.	TRIB	DCDOH	DCDOH	(1997) 3
ANA23	ANA23	ANACOSTIA R	ANATF	.	TRIB	DCDOH	DCDOH	(1997) 3
ANA24	ANA24	ANACOSTIA R	ANATF	.	TRIB	DCDOH	DCDOH	
ANA25	ANA25	ANACOSTIA R	ANATF	.	TRIB	DCDOH	DCDOH	(1997) 3
ANA26	ANA26	ANACOSTIA R	ANATF	.	TRIB	DCDOH	DCDOH	(1997) 3
ANA27	ANA27	ANACOSTIA R	ANATF	.	TRIB	DCDOH	DCDOH	(1997) 3
ANA29	ANA29	ANACOSTIA R	ANATF	.	TRIB	DCDOH	DCDOH	
ANA30	ANA30	ANACOSTIA R	ANATF	.	TRIB	DCDOH	DCDOH	2 (1990)
KNG01	KNG01	ANACOSTIA R	ANATF	.	TRIB	DCDOH	DCDOH	2 (1989)
KNG02	KNG02	ANACOSTIA R	ANATF	.	TRIB	DCDOH	DCDOH	2 (1991)
PMS01	PMS01	POTOMAC R	POTTF	.	TRIB	DCDOH	DCDOH	

Table A1-2

STATION	ORIGINAL STATION	WATERBODY	CBSEG 2003	STATION DEPTH <sup>1</sup>	PROJECT	AGENCY	SOURCE	NOTES
PMS03	PMS03	POTOMAC R	POTTF	.	TRIB	DCDOH	DCDOH	(1997) 3
PMS05	PMS05	POTOMAC R	POTTF	.	TRIB	DCDOH	DCDOH	(1997) 3
PMS07	PMS07	POTOMAC R	POTTF	.	TRIB	DCDOH	DCDOH	(1997) 3
PMS08	PMS08	POTOMAC R	POTTF	.	TRIB	DCDOH	DCDOH	(1997) 3
PMS09	PMS09	POTOMAC R	POTTF	.	TRIB	DCDOH	DCDOH	(1997) 3
PMS10	PMS10	POTOMAC R	POTTF	.	TRIB	DCDOH	DCDOH	
PMS11	PMS11	POTOMAC R	POTTF	.	TRIB	DCDOH	DCDOH	(1997) 3
PMS12	PMS12	POTOMAC R	POTTF	.	TRIB	DCDOH	DCDOH	(1997) 3
PMS13	PMS13	POTOMAC R	POTTF	.	TRIB	DCDOH	DCDOH	(1997) 3
PMS16	PMS16	POTOMAC R	POTTF	.	TRIB	DCDOH	DCDOH	(1997) 3
PMS18	PMS18	POTOMAC R	POTTF	.	TRIB	DCDOH	DCDOH	(1997) 3
PMS21	PMS21	POTOMAC R	POTTF	.	TRIB	DCDOH	DCDOH	
PMS23	PMS23	POTOMAC R	POTTF	.	TRIB	DCDOH	DCDOH	(1997) 3
PMS25	PMS25	POTOMAC R	POTTF	.	TRIB	DCDOH	DCDOH	(1997) 3
PMS27	PMS27	POTOMAC R	POTTF	.	TRIB	DCDOH	DCDOH	(1997) 3
PMS29	PMS29	POTOMAC R	POTTF	.	TRIB	DCDOH	DCDOH	
PMS31	PMS31	POTOMAC R	POTTF	.	TRIB	DCDOH	DCDOH	(1997) 3
PMS33	PMS33	POTOMAC R	POTTF	.	TRIB	DCDOH	DCDOH	(1997) 3
PMS35	PMS35	POTOMAC R	POTTF	.	TRIB	DCDOH	DCDOH	(1997) 3
PMS37	PMS37	POTOMAC R	POTTF	.	TRIB	DCDOH	DCDOH	
PMS39	PMS39	POTOMAC R	POTTF	.	TRIB	DCDOH	DCDOH	(2001) 3
PMS41	PMS41	POTOMAC R	POTTF	.	TRIB	DCDOH	DCDOH	(1997) 3
PMS44	PMS44	POTOMAC R	POTTF	.	TRIB	DCDOH	DCDOH	
PMS46	PMS46	POTOMAC R	POTTF	.	TRIB	DCDOH	DCDOH	(1997) 3
PMS48	PMS48	POTOMAC R	POTTF	.	TRIB	DCDOH	DCDOH	(1997) 3
PMS51	PMS51	POTOMAC R	POTTF	.	TRIB	DCDOH	DCDOH	
PTB01	PTB01	TIDAL BASIN	POTTF		0TRIB	DCDOH	DCDOH	
PWC04	PWC04	WASH. CHANNEL	ANATF	.	TRIB	DCDOH	DCDOH	
RCR01	RCR01	ROCK CRK	POTNT		0TRIB	DCDOH	DCDOH	
RCR04	RCR04	ROCK CRK	POTNT	.	TRIB	DCDOH	DCDOH	(1989) 3
RCR07	RCR07	ROCK CRK	POTNT	.	TRIB	DCDOH	DCDOH	(1997) 3
RCR09	RCR09	ROCK CRK	POTNT	.	TRIB	DCDOH	DCDOH	
TBK01	TBK01	POTOMAC R	POTNT	8.5	TRIB	DCDOH	DCDOH	
TCO01	TCO01	C&O CANAL	POTNT	0	TRIB	DCDOH	DCDOH	
TCO06	TCO06	C&O CANAL	POTNT	0	TRIB	DCDOH	DCDOH	
TDA01	TDA01	POTOMAC R	POTNT	7.9	TRIB	DCDOH	DCDOH	
TDU01	TDU01	ANACOSTIA R	ANANT	7.7	TRIB	DCDOH	DCDOH	

**Table A1-2**

STATION	ORIGINAL STATION	WATERBODY	CBSEG_2003	STATION DEPTH <sup>1</sup>	PROJECT	AGENCY	SOURCE	NOTES
TFB01	TFB01	FOUNDARY BRNCH	POTNT	12.3	TRIB	DCDOH	DCDOH	(2000) <sup>3</sup>
TFC01	TFC01	UT-ANACOSTIA R	ANANT	5.5	TRIB	DCDOH	DCDOH	
TFD01	TFD01	UT-ANACOSTIA R	ANANT	6.2	TRIB	DCDOH	DCDOH	
TFS01	TFS01	UT-ANACOSTIA R	ANANT	9.6	TRIB	DCDOH	DCDOH	
THR01	THR01	HICKORY RUN	ANANT	5.2	TRIB	DCDOH	DCDOH	
TNA01	TNA01	NASH RUN	ANANT	7.8	TRIB	DCDOH	DCDOH	
TOR01	TOR01	OXON RUN	POTTF	7.2	TRIB	DCDOH	DCDOH	
TPB01	TPB01	POPE BRNCH	ANATF	10.3	TRIB	DCDOH	DCDOH	
TTX27	TTX27	UT-ANACOSTIA R	ANANT	6.6	TRIB	DCDOH	DCDOH	
TUT01	TUT01	UT-ANACOSTIA R	ANANT	5.5	TRIB	DCDOH	DCDOH	(1995) <sup>3</sup>
TWB01	TWB01	WATTS BRNCH	ANANT	6.3	TRIB	DCDOH	DCDOH	
TWB05	TWB05	WATTS BRNCH	ANANT	.	TRIB	DCDOH	DCDOH	2 (1989)
TWB06	TWB06	WATTS BRNCH	ANANT	.	TRIB	DCDOH	DCDOH	2 (1989)

- 1 STATION DEPTH (meters) is mean total depth using 1985 (or earliest year) -2005 monitoring data.  
Total depth = . (missing) or 0 implies a shallow station and only surface samples collected.
- 2 For most stations, data are available from 1985 or earlier unless otherwise indicated by a different starting year in ( ).
- 3 Data collection is ongoing unless otherwise indicated with last year in ( ).

Table A1-3. Maryland Core Trend Stations in the Chesapeake Bay Watershed with data in the CIMS water quality database. There are a small number of Maryland Core Trend stations located outside the Chesapeake watershed but inside the state and whose data are not available in CIMS. Information about the Core Trend program, the data, and products related to the data are available at [link]. In the CIMS database, the Core Trend program is not identified as such; these stations have PROGRAM='WQMP', PROJECT='TRIB', AGENCY='MDDNR', SOURCE='MDDNR', the same as other Maryland tidal tributary stations.

**Table A1-3**

STATION	ORIGINAL STATION	LAB
ANT0044	ANT0044	MDHMH
ANT0203	ANT0203	MDHMH
ANT0366	ANT0366	MDHMH
BDK0000	BDK0000	MDHMH
BPC0035	BPC0035	MDHMH
CAC0031	CAC0031	MDHMH
CAC0148	CAC0148	MDHMH
ET5.0	CHO0626	MDHMH
CON0005	CON0005	MDHMH
CON0180	CON0180	MDHMH
DER0015	DER0015	MDHMH
GEO0009	GEO0009	MDHMH
GUN0125	GUN0125	MDHMH
GUN0258	GUN0258	MDHMH
GUN0476	GUN0476	MDHMH
GWN0115	GWN0115	MDHMH
JON0184	JON0184	MDHMH
MON0155	MON0155	MDHMH
MON0269	MON0269	MDHMH
MON0528	MON0528	MDHMH
NBP0023	NBP0023	MDHMH
NBP0103	NBP0103	MDHMH
NBP0326	NBP0326	MDHMH
NBP0461	NBP0461	MDHMH
NBP0534	NBP0534	MDHMH
NBP0689	NBP0689	MDHMH
NPA0165	NPA0165	MDHMH
PAT0176	PAT0176	MDHMH
PAT0285	PAT0285	MDHMH
POT1830	POT1830	MDHMH
POT2386	POT2386	MDHMH
POT2766	POT2766	MDHMH
TF1.0	PXT0603	MDHMH
PXT0809	PXT0809	MDHMH

**Table A1-3**

<b>STATION</b>	<b>ORIGINAL STATION</b>	<b>LAB</b>
PXT0972	PXT0972	MDHMH
SAV0000	SAV0000	MDHMH
CB1.0	SUS0109	MDHMH
TOW0030	TOW0030	MDHMH
WIL0013	WIL0013	MDHMH
XGG8251	XGG8251	MDHMH
CB3.3C	XHF1373	MDHMH
XJH6680	XJH6680	MDHMH

Table A1-4. Stations monitored by St. Mary's College as part of their St. Mary's River monitoring program (PROGRAM variable = 'SMRP'). The program began in 1999 and concluded in 2006.

**Table A1-4**

STATION	ORIGINAL STATION	WATERBODY	CBSEG_2003 <sup>1</sup>	STATION DEPTH <sup>2</sup>	PROJECT	AGENCY	SOURCE	NOTES
SMNT01	SMNT01	ST. MARYS RIVER.	POTNT	0	NTID	SMCM	SMCM	
SMNT02	SMNT02	ST. MARYS RIVER	POTNT	0	NTID	SMCM	SMCM	
SMNT03	SMNT03	ST. MARYS RIVER	POTNT	0	NTID	SMCM	SMCM	
SMNT04	SMNT04	ST. MARYS RIVER	POTNT	1.0	NTID	SMCM	SMCM	
SMNT05	SMNT05	ST. MARYS RIVER	POTNT	0	NTID	SMCM	SMCM	
SMNT06	SMNT06	ST. MARYS RIVER	POTNT	0	NTID	SMCM	SMCM	
SMNT07	SMNT07	ST. MARYS RIVER	POTNT	0	NTID	SMCM	SMCM	
SMNT08	SMNT08	ST. MARYS RIVER	POTNT	0	NTID	SMCM	SMCM	
SMNT09	SMNT09	ST. MARYS RIVER	POTNT	0	NTID	SMCM	SMCM	
SMNT09.5	SMNT09.5	ST. MARYS RIVER	POTNT	0	NTID	SMCM	SMCM	3 (2001)
SMNT10	SMNT10	ST. MARYS RIVER	POTNT	0	NTID	SMCM	SMCM	
SMNT11	SMNT11	ST. MARYS RIVER	POTNT	0	NTID	SMCM	SMCM	
SMNT12	SMNT12	ST. MARYS RIVER	POTNT	0	NTID	SMCM	SMCM	
SMNT13	SMNT13	ST. MARYS RIVER	POTNT	0	NTID	SMCM	SMCM	
SMNT14	SMNT14	ST. MARYS RIVER	POTNT	0	NTID	SMCM	SMCM	
SMSMC	SMSMC	ST. MARYS RIVER	POTNT	7.1	TRIB	SMCM	SMCM	4(2003)
SMT01	SMT01	ST. MARYS RIVER	POTMH	0.7	TRIB	SMCM	SMCM	4 (2004)
SMT02	SMT02	ST. MARYS RIVER	POTMH	2.9	TRIB	SMCM	SMCM	
SMT03	SMT03	ST. MARYS RIVER	POTMH	4.7	TRIB	SMCM	SMCM	4 (2002)
SMT04	SMT04	ST. MARYS RIVER	POTMH	7.4	TRIB	SMCM	SMCM	
SMT05	SMT05	ST. MARYS RIVER	POTMH	7.4	TRIB	SMCM	SMCM	4 (2002)
SMT06	SMT06	ST. MARYS RIVER	POTMH	7.7	TRIB	SMCM	SMCM	
SMT07	SMT07	ST. MARYS RIVER	POTMH	8.4	TRIB	SMCM	SMCM	
SMT08	SMT08	ST. MARYS RIVER	POTMH	2.9	TRIB	SMCM	SMCM	4 (2004)
SMT09	SMT09	ST. MARYS RIVER	POTMH	1.5	TRIB	SMCM	SMCM	
SMT10	SMT10	ST. MARYS RIVER	POTMH	3.7	TRIB	SMCM	SMCM	
SMT10A	SMT10A	ST. MARYS RIVER	POTMH	1.9	TRIB	SMCM	SMCM	4 (1999)
SMT10B	SMT10B	ST. MARYS RIVER	POTMH	1.4	TRIB	SMCM	SMCM	4 (1999)
SMT11	SMT11	ST. MARYS RIVER	POTMH	2.0	TRIB	SMCM	SMCM	3 (2001); 4 (2004)
SMT12	SMT12	ST. MARYS RIVER	POTMH	2.7	TRIB	SMCM	SMCM	3 (2001); 4 (2004)
SMT13	SMT13	ST. MARYS RIVER	POTMH	1.1	TRIB	SMCM	SMCM	3 (2003); 4 (2003)

1 The CBSEG\_2003 segmentation scheme did not take the St. Marys monitoring program into account and assign separate segment identities to the several salinity zones in which SMRP stations are found. The tidal river stations have been assigned to the adjacent mesohaline segment in the Potomac River main channel (POTMH) and the upstream St. Marys River stations have been assigned to the same segment (POTNT) as the nontidal, freshwater stations of the upper Potomac. These St. Marys River stations may 'contaminate' data retrieval and analysis that has the Potomac River as its focus and that selects all stations within these segments.



- Conversely, for the St. Marys River, grouping station using these segments could be inappropriate.
- 2 STATION DEPTH (in meters) is mean total depth using the full data record through 2005.
- 3 Data for most stations begins in 1999 unless otherwise indicated by this note and a different starting year in ( ).
- 4 Data collection is ongoing unless otherwise indicated by this note and the final year shown in ( ).

Table A1-5. Stations sampled in Elizabeth River (Virginia) Water Quality Monitoring Program (PROGRAM(s) =WQMP, ERMP).

**Table A1-5**

STATION	ORIGINAL STATION	WATERBODY	CBSEG 2003	STATION DEPTH	PROJECT	AGENCY	SOURCE	NOTES <sup>1</sup>
EBB01	EBB01	ELIZABETH RIVER	EBEMH	6.9	TRIB	VADEQ	VADEQ/TRO	01/98
EBE1	EBE1	ELIZABETH RIVER	EBEMH	8.6	TRIB	VADEQ	ODU	02/89
EBE1-E	EBE1-E	ELIZABETH RIVER	EBEMH	8.3	TRIB	VADEQ	ODU	09/01-11/01
EBE2	EBE2	ELIZABETH RIVER	EBEMH	9.3	TRIB	VADEQ	ODU	02/89-06/89
ELD01	ELD01	ELIZABETH RIVER	ELIPH	6.7	TRIB	VADEQ	VADEQ/TRO	01/98
ELE01	ELE01	ELIZABETH RIVER	ELIPH	10.4	TRIB	VADEQ	VADEQ/TRO	01/98
ELI1	ELI1	ELIZABETH RIVER	JMSPH	8	TRIB	VADEQ	ODU	02/89-06/89
ELI2	ELI2	ELIZABETH RIVER	ELIPH	13.3	TRIB	VADEQ	ODU	02/89
ELI3	ELI3	ELIZABETH RIVER	ELIPH	12.8	TRIB	VADEQ	ODU	02/89-06/89
LAF1	LAF1	ELIZABETH RIVER	LAFMH	5.8	TRIB	VADEQ	ODU	02/89-06/90
LE5.6	LE5.6	ELIZABETH RIVER	ELIPH	15.1	TRIB	VADEQ	VADEQ/TRO	02/85
LFA01	LFA01	ELIZABETH RIVER	LAFMH	4.1	TRIB	VADEQ	VADEQ/TRO	01/98
LFB01	LFB01	ELIZABETH RIVER	LAFMH	4.2	TRIB	VADEQ	VADEQ/TRO	01/98
SBA1	SBA1	ELIZABETH RIVER	SBEMH	12.2	TRIB	VADEQ	ODU	01/98
SBC1	SBC1	ELIZABETH RIVER	SBEMH	11.4	TRIB	VADEQ	ODU	10/98
SBD1	SBD1	ELIZABETH RIVER	SBEMH	11.8	TRIB	VADEQ	ODU	10/98
SBD4	SBD4	ELIZABETH RIVER	SBEMH	3.3	TRIB	VADEQ	ODU	01/98
SBE1	SBE1	ELIZABETH RIVER	SBEMH	12.3	TRIB	VADEQ	ODU	02/89-06/89
SBE2	SBE2	ELIZABETH RIVER	SBEMH	12.2	TRIB	VADEQ	ODU	02/89
SBE3	SBE3	ELIZABETH RIVER	SBEMH	9.3	TRIB	VADEQ	ODU	02/89-06/89
SBE4	SBE4	ELIZABETH RIVER	SBEMH	9.8	TRIB	VADEQ	ODU	02/89-06/89
SBE5	SBE5	ELIZABETH RIVER	SBEMH	8	TRIB	VADEQ	ODU	02/89
WBB05	WBB05	ELIZABETH RIVER	WBEMH	4.9	TRIB	VADEQ	VADEQ/TRO	01/98
WBE1	WBE1	ELIZABETH RIVER	WBEMH	4.4	TRIB	VADEQ	ODU	02/89

<sup>1</sup> Date range of water quality monitoring. End dates are shown where monitoring has been discontinued, otherwise monitoring is ongoing.

Table A1-6. Virginia Eastern Shore Water Quality Monitoring Program (PROGRAM=VEMP).

STATION	ORIGINAL STATION	WATERBODY	CBSEG 2003	STATION DEPTH	PROJECT	AGENCY	SOURCE	NOTES <sup>1</sup>
C-1	C-1	CHERRYSTONE INLET	CB7PH	.	TRIB	VADEQ /NFWF	VIMS	01/01-12/02
C-2	C-2	CHERRYSTONE INLET	CB7PH	.	TRIB	VADEQ /NFWF	VIMS	01/01-12/02
C-3	C-3	CHERRYSTONE INLET	CB7PH	.	TRIB	VADEQ /NFWF	VIMS	01/01-12/02
CS-3	CS-3	CHESCONESSEX CREEK	CB7PH	.	TRIB	VADEQ	VIMS	03/01-12/01
H-1A	H-1A	HUNGARS CREEK	CB7PH	.	TRIB	VADEQ	VIMS	01/01-01/01
H-1	H-1	HUNGARS CREEK	CB7PH	.	TRIB	VADEQ	VIMS	03/01-06/02
H-2	H-2	HUNGARS CREEK	CB7PH	.	TRIB	VADEQ	VIMS	01/01-06/02
H-3	H-3	HUNGARS CREEK	CB7PH	.	TRIB	VADEQ	VIMS	02/01-06/02
OC-3	OC-3	OCCOHANNOCK CREEK	CB7PH	.	TRIB	VADEQ	VIMS	03/01-12/01
ON-3	ON-3	ONANCOCK CREEK	CB7PH	.	TRIB	VADEQ	VIMS	03/01-12/01
OP-1	OP-1	OLD PLANTATION CREEK	CB7PH	.	TRIB	VADEQ	VIMS	01/01-06/02
OP-2	OP-2	OLD PLANTATION CREEK	CB7PH	.	TRIB	VADEQ	VIMS	01/01-06/02
OP-3	OP-3	OLD PLANTATION CREEK	CB7PH	.	TRIB	VADEQ	VIMS	01/01-06/02

1 Date range of water quality monitoring.

Table A1-7. Stations monitored by the US Geological Survey (USGS) as part of the River Input Monitoring Program (PROGRAM variable = 'RIM'). These stations are also referred to as 'fall line' stations because they are located at or near the head of tide where the conjoined discharge of the myriad streams of the watershed above is monitored before it meets the tidal waters. These stations are also provided in the full list of stations with data in the CIMS water quality database.

STATION	ORIGINAL STATION	USGS GAUGE #	WATERBODY	CBSEG_2003 <sup>1</sup>	STATION DEPTH <sup>2</sup>	PROJECT	AGENCY	SOURCE	NOTES
CB1.0	SUS0109	01578310	SUSQUEHANNA R	SUSNT	.	NTID	MDDNR	USGS	
ET5.0	CHO0626	01491000	CHOPTANK RIVER	CHOTF	.	NTID	MDDNR	USGS	
TF1.0	PXT0603	01594440	PATUXENT RIVER	PXTTF	.	NTID	MDDNR	USGS	
TF2.0	PR01	01646580	POTOMAC RIVER	POTTF	.	NTID	MDDNR	USGS	
TF3.0	TF3.0	01668000	RAPPAHANNOCK R	RPPTF	.	NTID	VADEQ	USGS	
TF4.0M	TF4.0M	01674500	MATTAPONI RIVER	MPNTF	.	NTID	VADEQ	USGS	
TF4.0P	TF4.0P	01673000	PAMUNKEY RIVER	PMKTF	.	NTID	VADEQ	USGS	
TF5.0A	TF5.0A	02041650	APPOMATTOX RIVER	APPTF	.	NTID	VADEQ	USGS	
TF5.0J	TF5.0J	02035000	JAMES RIVER	JMSTF	.	NTID	VADEQ	USGS	

1 The fall line stations are generally on the boundary of the segments and for general analytical objectives are not included among stations considered within the segment.

2 Many fall line stations are shallow, but if the station has significant depth, the sample is a depth-integrated sample.

## Appendix 2

### Water Quality Monitoring Programs in the CIMS Database

In broadest terms, the water quality monitoring database at present includes data from two kinds of programs: 1) long- and shorter-term programs with discrete water samples collected at fixed-stations at regular time intervals over the annual cycle, and 2) shallow water monitoring programs that focus on nearshore waters and collect temporally and spatially dense data using in-situ, continuous or high frequency sampling and recording technology as well as discrete sample collections for calibration and comparison with fixed-station information. These programs focus on an area for a shorter period, usually 3 years, and are used primarily to assess water quality status in the shallow water habitats and specifically to assess attainment of water quality Criteria. The Maryland Department of Natural Resources [[Eyes on the Bay](#)] and Virginia Institute of Marine Science [[VECOS](#)] conduct shallow water monitoring programs.

In context of the Users Guide, a distinction is made between *Programs*, *Projects*, *Sources*, and (data collecting) *Agencies*, which are also key selection variables in the CIMS water quality database. “Source” is usually the entity that funds data collection and provides the data to the Bay Program, “Agency” is usually the data collecting entity. Water quality programs currently in the database and their project subsets are shown in the schematic (Figure A2-1) and are described briefly below. Most, if not all of these programs have documentation at the Data Hub or links to the source for more information.

**Cautionary notes:** There is some inconsistency in the use of the Project, Source, and Agency variables. Also, users should be aware that a station may be sampled in more than one project or program and/or by multiple agencies. Parameters and analytical methods may be the same or different and the objectives of data collection are likely to differ. Depending on application, therefore, it may be useful or even critical to identify and subset data by PROJECT, PROGRAM, SOURCE and/or AGENCY.

#### **Program = WOMP: The CBP Water Quality Monitoring Program**

The data sets from water quality monitoring programs integrated under the umbrella of CBP basinwide monitoring are the core around which the CBP water quality database was structured and designed. The CBP fixed-station water quality monitoring programs are designed to enable managers to assess current conditions and monitor long-term changes in Bay water quality. Over the years, the mainstem Bay and tidal tributary components have matured into a well-integrated, unified program, but in 1984, they were at different stages of their evolution. The state tidal monitoring programs had been designed to comply with state and federal drinking water regulations and regulations stemming from the Clean Water Act in 1972. The USEPA, as

lead agency for the then-new Chesapeake Bay Program, took the lead in designing a program for the mainstem Bay that focused on the Chesapeake Bay as a dynamic estuarine system with major impacts from nutrient and sediment loading. The monitoring program design took into account the major physical and climatic forcing factors in the Bay and explored new laboratory analytical methods and technologies that were more appropriate to estuarine conditions and to the parameter concentrations encountered there. For many reasons, it took some time for the states to modify their existing programs to align with the main stem program and with the CBP's somewhat different objectives and reporting requirements.

### **Mainstem Bay and Tributary programs**

The states of Maryland (MDDNR) and Virginia (VADEQ) have the largest responsibility for overseeing the regular monitoring of the station network both in their tidal tributaries and in the mainstem Bay. The mainstem program (Project=MAIN) began in June 1984 with water quality parameters measured at 49 stations once each month during the colder late fall and winter months and twice each month in the warmer months. Monitored parameters include various species of the nutrients nitrogen, phosphorus and carbon; a measure of the photosynthetic pigment chlorophyll\_a, silicon, total suspended solids, volatile suspended solids, and a measure of water clarity and/or turbidity, in addition to water temperature, conductivity/salinity, dissolved oxygen and pH. From time to time, other parameters are added to the suite for a specified period to serve research and modeling information needs. Tidal and non-tidal tributary monitoring (Project=TRIB and NTID) data are provided to the CBP through state match and cooperative agreements. Most tidal tributary stations are sampled once per month. The tidal waters of the Potomac and Patuxent rivers are exceptions as they are major tributaries with enhanced temporal coverage. The District of Columbia Department of Health (DCDOH) has monitored and contributed data for non-tidal stations on the upper Potomac and Anacostia rivers since 1984. In addition to the long term monitoring at stations in the mainstem Bay and large tributaries on the western shore, Virginia added in early 1989 and has since enlarged a monitoring program in the Elizabeth River (Program=ERMP, Project=TRIB). Virginia also conducted water quality studies at twelve Virginia eastern shore stations for a short period: 2001-2002. (Program=VEMP, Project=TRIB).

### **Sampling scheme**

The sampling schemes of these programs are similar. At each station, a hydrographic vertical profile is made including measurements of water temperature, salinity, and dissolved oxygen among others, at approximately 1- to 2-m intervals. Water samples for laboratory chemical analysis (e.g., nutrients, pigments, sediments) are collected at strategic locations within the water column: from the surface and bottom usually, and at deeper, estuarine stations where salinity stratification occurs, characterized by the presence of a pycnocline, at depths representing upper (above-pycnocline) and lower (below pycnocline) layers. This is in contrast to freshwater stations and some current and historical monitoring programs where sample depths are fixed and predetermined. Generally, samples have been collected via pumping system rather than a discrete sample collection device.

### **Biological components**

The CBP integrated mainstem and tidal tributary monitoring program (WQMP) components include, or have included in the past, several biological components as well: phytoplankton,

zooplankton and benthic community studies. The zooplankton component was suspended after 2002, the phytoplankton program was suspended in Maryland for 2010, and the benthic program is still ongoing. The biological components, as well as the water quality monitoring program, changed over the years, but in general they are designed to provide corollary information that is useful for inferring consequences of water quality changes for the Chesapeake biota and larger ecosystem and assessing the ecological health of the Bay and tributaries. The biological data are part of the CBP Living Resources database and are accessible through the CIMS [Data Hub](#) on the CBP website.

### **Program = SWM: Shallow Water Monitoring program**

These programs began as pilot programs in 1998 and were fully fledged by 2003. They have several objectives:

- To assess status relative to ambient water quality criteria for dissolved oxygen, chlorophyll and water clarity in shallow water habitats, with the goal of removing the Chesapeake Bay and its tidal rivers from the US Environmental Protection Agency list of impaired waters.
- In conjunction with data from other water quality stations and living resources monitoring projects, to understand linkages, temporal variation and long-term trends;
- To refine, calibrate and validate Chesapeake Bay ecological models.

### **Fixed-site, in-situ continuous monitoring calibration data (Project=CMON)**

At selected shallow water sites along the shoreline of the mainstem Bay and tributaries, YSI 6600 data loggers are deployed to sample a number of environmental parameters: water temperature, salinity, dissolved oxygen concentration, oxygen percent saturation, pH, turbidity, and chlorophyll fluorescence. Each parameter is sampled semi-continuously at 15-minute intervals, and deployments are scheduled to be in place for up to 3 years. The data loggers are exchanged weekly or bi-weekly and when they are exchanged, 'calibration' samples for pigments, nutrients and suspended solids are collected for laboratory analysis. These are grab samples collected at 1 m below the surface. A Secchi depth measurement and HydroLab CTD vertical profile are also made at this time. The data structure, parameters and other variables in the calibration data sets are similar to the long term water quality data sets and thus stored in this database with other water quality data. The high frequency, semi-continuous data from the data loggers themselves are available at [\[link\]](#) and archived results can be found at [\[link\]](#).

### **Longitudinal in-situ continuous monitoring calibration (Project=DFLO)**

Selected segments are monitored monthly using a flow-through sampling system (Dataflow®) that records water quality parameters in conjunction with latitude and longitude every 3-4 seconds (about every 30 m) along a cruise track, providing high resolution information in time and space. Seven water quality parameters are measured: water temperature, salinity, conductivity, dissolved oxygen, turbidity, fluorescence and pH as well as water depth to the bottom. The DataFlow system samples water at approximately 0.5-m below the surface.

As in the fixed-site continuous monitoring program, calibration samples for laboratory analysis are collected at numerous sites along the cruise track. Pigments, nutrients and sediment parameters are measured including: chlorophyll *a*, total dissolved nitrogen, particulate nitrogen, nitrite, nitrite + nitrate, ammonium, total dissolved phosphorus, particulate phosphorus, orthophosphate, dissolved organic carbon, particulate carbon, silicic acid, total suspended solids, volatile suspended solids, and turbidity. Also as above, the calibration data are included in this water quality monitoring database. The high frequency, semi-continuous data from the data loggers themselves are available at [\[link\]](#) and archived results can be found at [\[link\]](#).

**Program = RIM: The River Input Monitoring Program (Project=NTID)**

This program includes a special subset of stations located in the major tributaries at or near the Piedmont fall line, generally the transition zone between tidal and non-tidal stations. These stations include gauges that collect continuous freshwater discharge measurements along with monthly or more frequent measurements of water quality parameters. At these stations, additional samples are collected during storm events. Estimates of nutrient and sediment loads discharged from the watershed into tidal waters are derived from the flow and concentration data collected at these sites.

**District of Columbia Water Quality Monitoring Project (Program=WQMP Project=TRIB Source=DCDOH)**

The District of Columbia Water Quality Monitoring Program is coordinated with the Maryland and Virginia monitoring program and with the Metropolitan Washington Council of Governments. The Program consists of a 76-station network including the Potomac and Anacostia rivers, the Chesapeake and Ohio Canal, the Washington Ship Channel, and the Washington Tidal Basin. Sampling is conducted monthly, but 20 times per year at core stations. Short-term and intensive sampling is also conducted on an as-needed basis. The purpose of monitoring is to characterize water quality conditions and detect long-term trends in water quality response to various control strategies in order to maintain the environmental integrity of District waters, to detect potential health hazards and maintain these waters as a valuable resource.

**Program = SNAP: Susquehanna Nutrient Assessment Program (Project=NTID)**

The Susquehanna River Basin Commission implemented a five-year nutrient-monitoring program in October 1984 to establish a database for estimating nutrient and suspended sediment loads in the Susquehanna River Basin. This monitoring effort, conducted as part of the Chesapeake Bay Restoration Program, consisted of monthly base flow sampling and periodic sampling throughout the high flow hydrograph for a minimum of five storms per year. Initially, 12 sampling sites were established. This sampling network included a series of mainstem and major tributary sites, and a series of sites located on smaller watersheds that had significant areas of specific land use, or representative combinations of land uses. Data from such sites were necessary to enable accurate allocation of nutrient and suspended sediment loads to the main river reaches and to major sub-basins. The initial five-year program was concluded at the end of



December 1989, and five of the twelve original sites were selected for continued long-term monitoring.

In October 2004, 13 additional sites were added to the monitoring network as part of the CBP non-tidal monitoring network. This effort was led by the CBP Non-tidal Water Quality Workgroup with these objectives: to measure and assess the actual nutrient and sediment concentration and load reductions in the tributary strategy basins across the watershed; to improve calibration and verification of partner's watershed models; and to help assess the factors affecting nutrient and sediment distributions and trends.

### **Other water quality monitoring data in the CIMS database.**

**Maryland's CoreTrend Monitoring Program** has origins predating the CBP. The State began long term ambient water quality monitoring at this core set of stations in the mid 1970's in response to the national Clean Water Act (1972). Terms such as "106 monitoring" and "305B reports" refer to requirements emerging from that legislation. With the inauguration in 1984 of the USEPA Chesapeake Bay Program water quality monitoring program in the mainstem Bay, it was clear that tributary data collections should be integral to that effort and selected tidal stations were incorporated into the basinwide CBP tributary sampling network described above (Program=WQMP, Project=TRIB, NTID). The core/trend stations that serve this dual duty are indicated as such in the station tables in Appendix 1. In other aspects, Maryland's core/trend program has remained intact serving its original objectives, but evolving over time to be as consistent as practicable with the basinwide programs.

Several multi-year fixed-station studies were or are still being conducted by other entities in some smaller tributaries, which data are also available in CIMS:

**The St. Mary's River Project** is a monitoring program conducted by St. Mary's College. The St Mary's River is a southern tributary of the Potomac River; sampling of its tidal and non-tidal waters was begun in 1999 and ended in 2007 (Program=SMRP, Project=TRIB, NTID).

**The Indian Head Division Naval Surface Warfare Center (IHDNSWC) Monitoring Project on Mattawoman Creek** was begun in 2000 and ended in 2004 (Program=IHMP, Project = TRIB).

**The Susquehanna River** is sampled by the Susquehanna River Basin Commission (SRBC). Data are available beginning in 1984 (Program=SNAP, Project=NTID).

**The National Estuarine Research Reserve System (NERRS)** is a federal (NOAA)-state partnership. The 25 separate reserves have effectively partnered to develop a system wide monitoring program (SWMP) that has continuously measured salinity, temperature, dissolved oxygen, pH, and turbidity at two or more locations for the past several years. Also meteorological data is usually collected in close proximity to the water quality station. SWMP data has been used to examine estuarine response to extreme weather events and to examine DO in shallow water systems. The data for Chesapeake Bay can be found at an external [[link](#)] at the

Data Hub.

## A brief history of the CBP Monitoring Program

The conceptual design of a monitoring program for Chesapeake Bay was laid out in Appendix F of CBP (1983b), "Chesapeake Bay: A Framework for Action." This design built on previous Chesapeake Bay monitoring programs, avoiding their weaknesses while addressing monitoring, research, and management needs in an integrated fashion. The authors proposed a "Water Quality Baseline Monitoring" scheme (CBP 1983b, Appendix F, Attachment 6) that was largely followed in the current CBP monitoring program. Much about Bay hydrology and the importance of circulation patterns and estuarine processes was becoming known at that time, and the Program was designed to take these into account. A fundamental part of that design was to characterize the structure of the water column and to sample nutrients and other water quality constituents above and below the pycnocline at stratified stations, in addition to surface and bottom samples. The pycnocline is the region of the water column where density changes rapidly due to salinity and temperature differences. Previous monitoring had used fixed-depth sampling, which did not always adequately characterize the upper and lower water masses at stratified stations. The authors also stressed the need for "built-in flexibility," which is an important part of the current program. This flexibility is illustrated by the changes that have occurred in the CBP monitoring program since 1984.

### The Main Bay

The early Chesapeake Bay Water Quality Monitoring Program is documented in CBP (1989), "Chesapeake Bay Basin Monitoring Program Atlas." The Program began first in the main stem Bay in June 1984 with 50 stations: 22 in Maryland and 28 in Virginia. For continuity, a number of stations visited historically by Bay researchers and sampled in earlier surveys were included in the new station network. All stations were sampled once each month during the late fall and winter months and twice each month from March through October. As is done currently, surface and bottom samples were collected for nutrient analysis at all stations, and two mid-water samples, from above and below the pycnocline, were added where the water column was stratified. The original collecting organizations were Maryland Department of the Environment ((MDE), Virginia Institute of Marine Sciences (VIMS), and Old Dominion University (ODU) and they strived to sample their respective regions within the same 3-day window. Now, Maryland Department of Natural Resources (MDDNR) samples the MD stations, and as of January, 1996 ODU samples all the VA mainstem stations. The Monitoring Cruise Schedules from 1984 through 2010 are available on the website under Data Hub, Water Quality, CBP Water Quality Database (1984-present), Documentation, Water Quality Monitoring Cruise Schedules [[link](#)].

The sampling frequency has been changed since the beginning of the program, and cruises have occasionally been disrupted partially or completely due to weather or mechanical difficulties. Beginning in 1988, to reduce program costs, the Virginia institutions eliminated one of the March collections, and in 1989 eliminated the 2<sup>nd</sup> cruise in October; Maryland continued the original schedule. Maryland continued with two March and two October collections through 1995, however sampling of the lateral stations (CB3.3E, CB3.3W, CB4.1E, CB4.1W, CB4.2E, CB4.2W, CB4.3E, CB4.3W) during the winter season was discontinued in 1990. In 1996 Maryland dropped the January and February cruises to save money for possible special sampling needs throughout the year, and the second March, June, September and October cruises were also

dropped. The January and February cruises were reinstated in 1998. In January 1996, Virginia consolidated sampling to one organization, and ODU began monitoring all the Virginia mainstem stations, dropping the second April, May, June and September cruises. In 2004 the second June and September cruises were reinstated for both Maryland and Virginia.

### **The Tributaries**

In 1984, monitoring programs of different design were already in place in the major tributaries to provide local water quality information required by federal (USEPA) and state authorities. The state tidal monitoring programs had been put in place to comply with state and federal drinking water regulations and regulations stemming from the Clean Water Act in 1972. It took time to modify these programs so that they could meet old obligations and integrate with the basinwide monitoring and management approach promoted by the Chesapeake Bay Program.

The laboratory analyzing water samples for the MD main Bay program was initially the EPA Central Regional Laboratory (CRL), but quickly was changed to the University of Maryland Chesapeake Biological Laboratory (CBL). At CBL, academic chemists were exploring and using different analytical methods more appropriate for estuarine waters and urging adoption of these methods as standard for the monitoring programs. The laboratory serving the MD tributary monitoring programs was the Maryland Department of Health and Mental Hygiene (MDHMH).

Maryland focused first on the Patuxent and Potomac rivers for special attention and integration with the main Bay program. Both rivers are cultural icons in the region, with histories of abundant wildlife and aquatic living resources. They both have high profile wastewater treatment plants and other industrial dischargers along their shores and their wastewater treatment plants have been upgraded for biological nutrient removal. Both the Patuxent and Potomac rivers are relatively intensely monitored with samples collected twice a month between March and October. The Patuxent station density is higher than most other monitored tributaries; the Potomac is hindered in this respect, since there are military exclusion zones on some parts of the river. In July 1990, CBL took over the analysis of water samples in the Patuxent River program, except for the spectrophotometric analysis of chlorophyll samples, which responsibility MDHMH retained. With the change in laboratory came a change in analytical methods. CBL championed the oceanographic methods already implemented in the main Bay program and these were then implemented in the Patuxent as well. In May 1998, CBL took over laboratory analysis of the Potomac water quality samples and implemented the method and parameter changes in that program as well.

**Figure A2-1. Programs, projects and agencies contributing data to the**

## Chesapeake Bay Information Management System

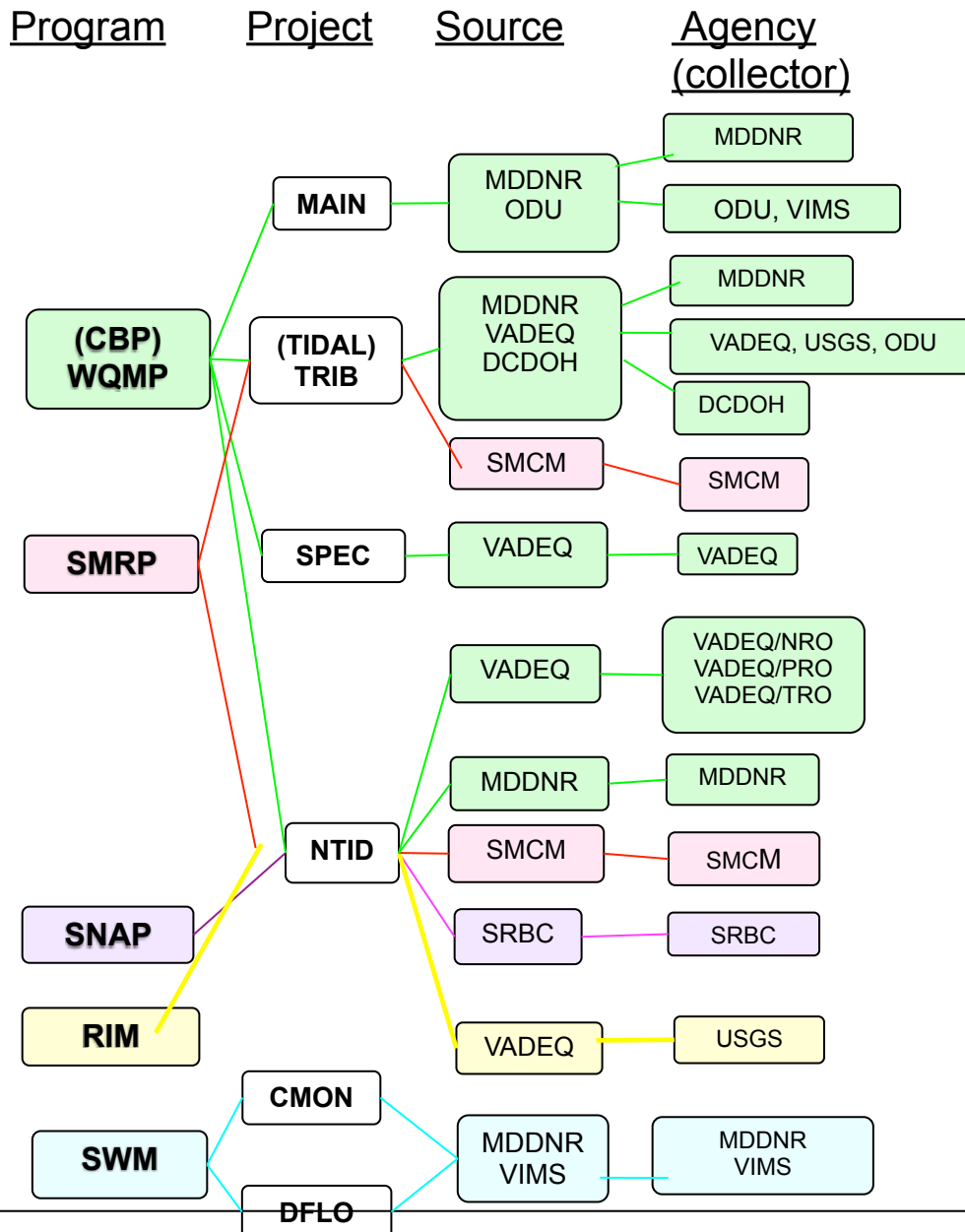

<p><b>Programs:</b>  WQMP=Water Quality Monitoring Program  SMRP =St. Marys River Project  SNAP =Susquehanna Nutrient Assessment Pgm  RIM =River Input Monitoring program  SWM =Shallow Water Monitoring program</p> <p><b>Projects:</b>  MAIN = Main stem Bay  TRIB = Tributaries (tidal)  SPEC = Special  NTID = Nontidal  CMON =Continuous (temporal) monitoring  DFLO = DataFlow (continuous spatial) monitoring</p>	<p><b>Sources and Agencies:</b>  DCDOH = DC Department of Health  MDDNR = MD Dept of Natural Resource  ODU = Old Dominion University  SMCM = St. Marys College of Maryland  SRBC = Susquehanna River Basin Commission  USGS = US Geological Service  VADEQ = Virginia Dept. of Environmental Quality  /NRO = Northern Regional Office  /PRO = Piedmont Regional Office  /TRO = Tidewater Regional Office  VIMS = Virginia Institute of Marine Science</p>
--	---

Appendix 3

Analytical Methods, Method Changes and Detection limits

Analytical methods and their detection limits became sticky issues early in the CBP monitoring

program. At the start of the Program (1984), most of the laboratory methods for analysis of water quality parameters were developed to test for compliance with drinking water or wastewater standards in fresh water or to measure parameter levels in the highly saline, nutrient poor waters of the ocean. Different methods were necessary for an estuary characterized by wide ranges in background salinity, turbidity, nutrients and other parameters of interest. For the most part, available methods worked optimally either for concentrations higher or lower than typically encountered in Chesapeake Bay tidal waters. In addition, the most appropriate methods were often unable to reliably measure concentrations at or near target restoration levels, should they be achieved. Since 1984, advances in water chemistry and instrumentation have resulted in more appropriate methods, usually bringing with them better precision, accuracy and lower detection limits. These improvements are a mixed blessing in some ways, as explained below in the section on trend and time series analysis and as evidenced by the number of entries on this subject logged into the Data Analysis Issue Tracking System (see DAITS Table, Appendix 4).

### **Method Codes**

In the CIMS water quality database, each parameter value is associated with a METHOD variable whose value is a defined code that documents how the parameter measurement was obtained. The full list of codes is available in the online [Water Quality Data Dictionary](#) listed under water quality *Documentation*, and an example fragment is below (Table A3-1). Note that the online table includes up to four references that describe the method in detail and may include papers relevant to Chesapeake Bay water quality data.

Method codes have defined formats. The initial letter of the method code indicates the following:

- ‘L’ = laboratory method;
- ‘F’ = field measurement, i.e., a parameter measured with onboard instrumentation;
- ‘D’ = derived parameter, calculated from constituent parameters in the database; and
- ‘C’ = calculated parameter, but differs from a ‘D’-coded parameter in that all necessary constituent parameter values are not available in the database and must be used as if it were a directly measured parameter. It is permanently retained as a primary observation in the database because it is the only available estimate of the parameter.

If a method is substantively different from others, the method is assigned a different number (e.g., L01 versus L02).

For calculated parameters, i.e., those with leading letter ‘D’, a trailing letter indicates how constituents with above or below detection limit values were treated:

- ‘A’ indicates that values below the minimum detection limit were set to the minimum detection limit.
- ‘B’ indicates that values below the minimum detection limit were set to one-half the minimum detection limit.
- ‘C’ not currently defined.
- ‘D’ indicates that values above the maximum detection limit were set to the maximum detection limit.

Users can use these internal codes in programming statements to detect method changes and

make user-specified adjustments as desired. Table A3-2 lists most of the measured and commonly calculated parameters and their method codes.

### **Method Changes**

A chronology of sorts of analytical methods and their detection limits is given in Tables A3-3a (main Bay programs) and b (tributary programs). Method codes are included in the table and substantive method changes (where changes in method codes occur) are indicated in the right hand column. The table was incompletely updated in 2006-07. In some cases, more research is needed to fill in blanks.

The laboratories instituted several broad categories of change over the years. One involves a change from older EPA standard methods to oceanographic methods for nutrients (nitrogen and phosphorus compounds) and carbon. In the old EPA standard methods, total and dissolved species are measured directly and their particulate forms are derived by subtracting the dissolved fractions from the total. In oceanographic methods, dissolved and particulate fractions are measured directly and total amounts of the elements are obtained by adding dissolved and particulate fractions. In estuarine waters, the EPA methods could produce negative values for calculated particulate parameters, and the nitrogen method (Kjeldahl) does not perform well (D'Elia et al, 1987). In the mainstem monitoring program, that change took place early on, in October 1987. In the tidal tributary programs, that change was implemented much later: in 1994 for the Virginia tributary programs and in 1998 for most Maryland tributaries.

The second broad category of change was the switch from whole water sample analysis to analysis of field-filtered pre-processed water samples. Maryland's CORE/Trend program is a legacy water quality monitoring program dating from 1974 to the present. It includes mostly non-tidal waters of the upper tributaries and, over time, protocols and methods were modified to better integrate with the CBP mainstem and tributary monitoring programs. From 1974 through June 2005, the CORE/Trend analytical laboratory (MD Dept of Health and Mental Hygiene) performed analyses on whole water samples brought from the field. Then the laboratory transitioned to equipment and methods that enabled them to perform analyses on field-filtered samples, thereafter achieving consistency with other CBP-partner labs. The differences between whole water and field-filtered methods are sufficient to warrant different parameter names, e.g., PO4W versus PO4F, and for a number of parameters, the differences are sufficient to warrant a 'correction' factor if the analytical time period includes data collected by both methods. (See DAITS issue #043 for more details.)

### **Definition and determination of method detection limits**

The minimum detection limit (MDL, also referred to as the Method Detection Limit) for laboratory analyses is the lowest parameter concentration that the measurement system can detect reliably. Some laboratories determine MDLs annually, while others determine them only when there is a method change. The method for determining the MDL varies among laboratories and has varied over time within labs. The method used at most CBP laboratories was agreed to by members of the CBP Analytical Methods and Quality Assurance Workgroup (AMQAW) in 1988. By this method, the MDL is 3 times the standard deviation of 7 low-level replicates. This

method has been used at CBL since 1987, and at VIMS starting in May 1988. At VIMS before May 1988, MDLs for low-concentration samples were based on the lowest standard used. The MDL method used at EPA Central Regional Laboratory (CRL) before May 1985 is unknown, but was probably based on lowest standard used.

Until 2011, ODU calculated their MDL as 3 times the standard deviation of 7 low-level replicates, but adjusted the MDL upwards if necessary to be at least 1-2% of full scale for that parameter. This resulted in an MDL that is similar to an Instrument Detection Limit. The Virginia and Maryland State Laboratories (DCLS and DHMH) use the method in Title 40 CFR Part 136 – Appendix B, to calculate MDL. By this method, the MDL is 3.14 times the standard deviation of 7 low-level replicates. In 2010, AMQAW recommended that all labs follow this procedure to establish their MDLs, i.e. ODU and CBL agreed to be consistent with DCLS and DHMH.

For calculated parameters, including those obtained both by addition and subtraction, the MDL is the sum of the detection limits of the individual components.

For field parameters, the detection limits are generally the “calibrated accuracy” as determined by the manufacturer of the instrument they use (e.g., Hydrolab, Yellow Springs Instruments) and field data are not censored at these values. MDLs for field measurements are not available through CIMS.

### **Reporting detection limit versus actual, empirical detection limit**

There is also a *Reporting* detection limit whose value may or may not be the same as the method detection limit. The basis of reporting limits varies among laboratories. Commonly, it is the lowest parameter concentration standard used by the laboratory or authorized for the purpose, and the standard may be higher or lower than the method can reliably detect. In some contexts, laboratories are required to use the Reporting Detection Limit rather than the empirical MDL and this has caused some inconsistencies in the water quality database, particularly in the early years of the Program. Both Reporting and Actual Method detection limits are given in Tables A3-3a and b, below. Note that particulate parameters are the most likely to have different Reporting and Actual detection limits, e.g., CHLA and PHEO, PC, PN, PP, TSS, FSS, although that is not always true. Users should compare parameter values flagged as below detection with published method detection limits to determine if this is an issue of concern.

### **Handling censored values in data analysis**

In the CIMS database, parameter measurements that are above or below the analytical detection limit are censored and assigned the values of the detection limits. The laboratories submit data to CIMS in this censored format. Data users handle these censored values in various ways, depending on their objectives. Many use the censored values as provided. Some choose to set these values to one-half the detection limit, i.e., to one-half the value in the database, in order to account in some measure for the unknown actual distribution of true values between 0 and the method’s detection limit. This is the current practice for CBP analysts for most routine projects. Some users elect to set censored values to zero or to missing.



None of these approaches eliminates the problem that all censored values, regardless of the approach used, are equal to one another. This characteristic of censored data sets is particularly problematic when detection limits are relatively high and analytical objectives involve statistical comparisons, ranking procedures, trend analysis or time series analysis. Other censoring methods attempt to eliminate this problem by removing censored values altogether or by using a randomization technique and the parameter's variability above its detection limit to generate expected values between zero and the MDL censoring level. None of these methods are completely satisfactory for all situations.

All of these adjustment methods are unsatisfactory in one way or another and are particularly problematic in trend and time-series analyses. The CBP is experimenting with eliminating data censoring and using uncensored 'raw' laboratory values, incorporating the detection limit as part of the confidence estimates around the results. This is controversial because release of such data runs counter to long standing data quality reporting rules of the laboratories. The issue is discussed in more detail below (see section on Using censored data, below).

### **Effect of detection limit changes on trend and time-series analyses**

Changes in detection limits (usually decreases), even without major changes in analytical methodology, can introduce "step trends" and confound trend and time series analyses when ambient concentrations are not consistently above the detection limit. For example, Figure 1 shows 10 years of data for total dissolved phosphorus at a lower Bay station. The MDL at the beginning of period was 0.01 mg/L and, by the end of 2004, it had been reduced a number of times and was at 0.0011 mg/L, as indicated by the stepped horizontal line just above the Time axis.

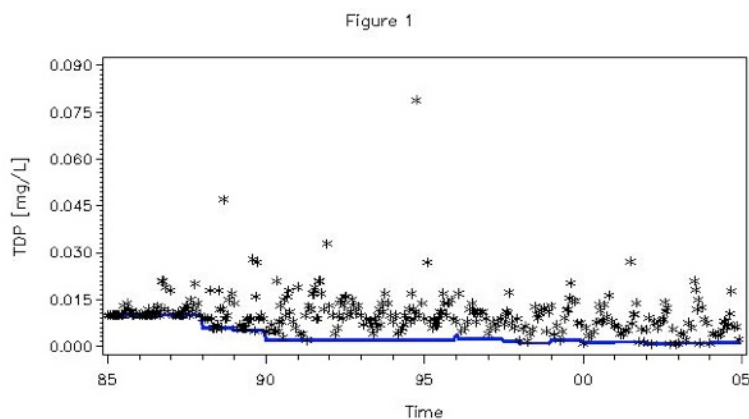

At this site, TDP was frequently below the early MDLs, but lower and lower concentrations were reported as the detection limit was reduced, suggesting significant reductions in TDP over the period. To eliminate artificial trends introduced by detection limit changes, CBP analysts censor values based on the highest detection limit in place during the period of analysis. Each data value in the time period is compared to the censoring detection limit and if it is smaller, the value

is set to one-half the censoring detection limit. For example, to test for trends in the TDP data above between 1985 and 2004, the analyst would identify 0.01 mg/L as the highest MDL in the period and set all values less than that to one-half, to 0.005 mg/L. To test for trends since 1995, the analyst would identify 0.005 mg/L (in place since before January 1995) as the highest MDL in the analytical period and censor all values less than that to 0.0025 mg/L. Since it is usually important to know the number of censored measurements in an analysis, CBP analysts typically flag censored values (i.e., set the flag to '<') in their datasets.

Cautionary note: The example above is not representative of all situations. Users should examine their data to determine the highest MDL concentration actually censored during the period to be analyzed. For example, in the synthesized data plotted in Figure 2, ambient TDP concentrations were all above the relatively high 0.01 mg/L MDL early in the time period and first fall below the MDL later in the time series when the detection limit of 0.005 is in effect.

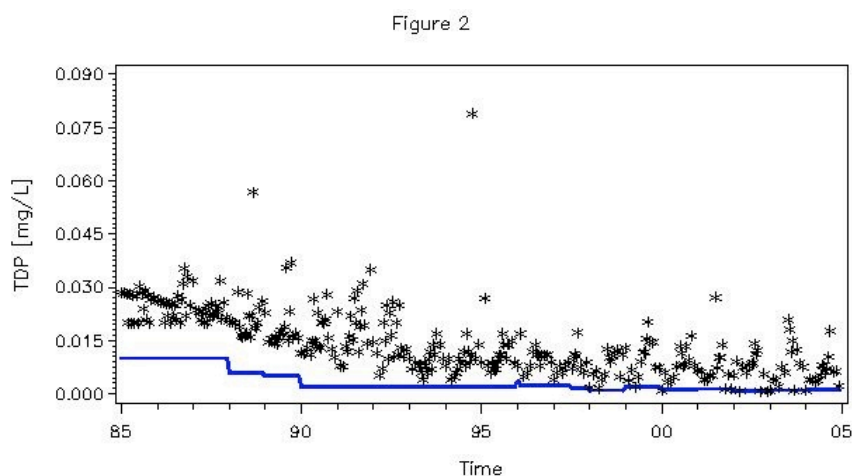

In this case, the highest effective detection limit in the time period is 0.005 mg/L and this is the censoring level the analyst should use in the trend analysis. He would thus not have to forego the benefit of the lower detection limit in effect in the latter portion of the data set. Users should examine the detection limit situation separately for each parameter and for the individual components of calculated parameters (e.g., total nitrogen) and for each location to determine which historical detection limits should apply.

### **Using uncensored data**

Various suggestions have been put forward to get around the censoring problem, including those mentioned above. In addition to these approaches, the CBP Monitoring Subcommittee Data Analysis Workgroup investigated the option of providing uncensored laboratory data to potential users (DAITS #033). This approach is controversial because the release of such data runs counter to longstanding data quality reporting rules of the laboratories. In addition, data sets that are uncensored can include small negative values that are counter-intuitive.

A compromise was struck between the Analysis Workgroup and the analytical laboratories in which the laboratories would continue to submit data censored to the MDL for use by the general public and also submit the uncensored values in a separate data set that would remain available

only to analysts familiar with the context and qualified uses of such data. Data submissions of uncensored data were phased in gradually in 1996 for the main stem program and in 1998 to 1999 for the Maryland and Virginia tidal tributaries. Submission of uncensored data is now a grant requirement for most projects fully or partially funded by the Chesapeake Bay Program but optional for other water quality data submitted to CIMS. Uncensored data are voluntarily provided by the River Input Monitoring Program as well as other federal and state non-tidal programs. Other projects such as the Shallow Watering Monitoring and Continuous Monitoring programs include uncensored data in their calibration data submissions.

Access to the uncensored data is controlled by the CBP Water Quality Data Manager. The manager may request information about the user's context, application and ultimate objectives before releasing the data. The data manager is required to send the request to the CBP project managers at Maryland DNR and Virginia DEQ, and access to uncensored data is granted pending that approval. Once approved, the name is put on a user list maintained by the CBP Data Center and the data are made available by the CBP Water Quality Data Manager.

Table A3-1. Example fragment of online table of METHOD codes (Water Quality Data Dictionary). Example shows two methods for total dissolved nitrogen (TDN). In method L01, the leading letter 'L' indicates that TDN is obtained through laboratory analysis. In method D01A, the leading code letter 'D' indicates that TDN is calculated from other directly measured parameters, TKNF and NO23F, and trailing 'A' indicates that any constituents below the minimum detection limit were set to that detection limit.

DESCRIPTION	DETAILS	EPA METHOD	INTR	METHOD	_ID	PARAM	REF 1	REF 2	REF 3	REF 4	TITLE
PRE-FILTERED SAMPLES ARE RUN THROUGH AN ALKALINE PERSULFATE WET OXIDATION TO CHANGE ALL N-CONTAINING COMPOUNDS INTO NITRATE. NITRATE CONCENTRATION IS DETERMINED USING AN AUTO ANALYZER EQUIPPED WITH A CADMIUM REDUCTION COLUMN.				L01	55	TDN	D'ELIA; C.F.; P.A. STEUDLER AND N. CORWIN. 1977. DETERMINATION OF TOTAL NITROGEN IN AQUEOUS SAMPLES USING PERSULFATE DIGESTION. LIMNOL. & OCEANOGR. 22:760-764	VALDERRAMA; J. C. 1981. THE SIMULTANEOUS ANALYSIS OF TOTAL NITROGEN AND TOTAL PHOSPHORUS IN NATURAL WATERS. MAR. CHEM 10:109-122.	EPA. 1983. METHODS FOR CHEMICAL ANALYSIS OF WATER AND WASTES. USEPA 600/479		ALKALINE PERSULFATE WET OXIDATION + EPA 353.2 OR EPA 353.4
[TDN] = [TKNF] + [NO23F]. CONSTITUENT VALUES BELOW MINIMUM DETECTION ARE SET EQUAL TO THE CONSTITUENT'S MINIMUM METHOD DETECTION LIMIT.				D01A	182	TDN					DATABASE CALCULATED TDN - METHOD 1 - MDL

Table A3-2. Measured and Calculated Laboratory Parameters and their method codes

Parameter	Measured Directly	Method code(s)	Calculated	Method code(s) <sup>1</sup>
<b>Carbon:</b>				
DOC	√	L01-03		
PC(POC)	√	L01	TOC – DOC	D01
TOC	√	L02	DOC + PC(POC)	D01
<b>Nitrogen:</b>				
NO23F(W)	√	L01, C01		
NO2F(W)	√	L01-02		
NH4F(W)	√	L01		
TKNF(W)	√	L01-03		
NO3F(W)		C01	NO23F(W) – NO2F(W)	D01
TDN	√	L01	TKNF+NO23F; TKNF + NO2F + NO3F	D01; D02
DIN			NO23F + NH4F; NO2F + NO3F + NH4F	D01; D02
DON			TKNF-NH4F; TDN-NH4F-NO23F; TDN-NH4F-NO2F-NO3F	D01; D02; D03
PN(PON)	√	L01	TKNW-TKNF;	D01
TON			TKNW – NH4F; PN+TDN-NH4F-NO23; PN+TDN-NO2F-NO3F	D01; D02 D03
TN	√	L01	TKNW + NO23F; TKNW+NO2F+NO3F; PON+TDN; PN+TDN; TKNW+NO23W	D01-02; D03, D04, D05
<b>Phosphorus:</b>				
TDP	√	L01-05		
PO4F(W)-	√	L01-03		
DOP			TDP - PO4F;	D01
PIP	√	L01		
PP	√	L01	TP – TDP	D01
TP	√	L01 - 04	TDP + PP	D01
<b>Other:</b>				
TSS; SI	√; √	L01; L01		
<b>Phytopigments:</b>				
CHLA		L01	26.7 [(OD664B-OD750B) -(OD665A-OD750A)]* K <sup>2</sup>	
		L02	26.73*[(OD663B-OD750B) -(OD665A-OD750A)]*K <sup>2</sup>	
PHEO		L01	26.7 [1.7(OD665A-OD750A) - (OD664B-OD750B)] K <sup>2</sup>	
		L02	26.73*[1.73(OD665A-OD750A) - (OD663B-OD750B)]* K <sup>2</sup>	

<sup>1</sup> The codes as shown here do not include trailing letters (e.g., D01A) that indicate how above- and below-detection-level values are handled.

<sup>2</sup> where K=extract volume/sample volume x light path)

Table A3-3a. A chronology of analytical methods and their detection limits in the CBP main Bay water quality monitoring programs.

Lab	Param	Start	End	Reported	Actual	Method	Chng?
<u>Applied Marine Research Lab (AMRL,ODU) / Old Dominion U.(ODU,ODU) as of May 2000</u>							
AMRL/ODU	CHLA	27JUN84	16NOV84	1.1000	0.0000	L02	
		11DEC84	08JAN95	1.1000	0.0000	L01	<
		09JAN95	15MAY96	1.6000	1.6000	L01	
		16MAY96	10JUL96	2.2500	0.0000	L01	
		11JUL96	13JAN97	1.2700	1.2700	L01	
		14JAN97	31DEC97	1.1200	1.1200	L01	
		01JAN98	31DEC98	1.2200	1.2000	L01	
		01JAN99	31DEC99	0.6600	0.6600	L01	
		01JAN00	30APR00	0.3500	0.3500	L01	
		01MAY00	31DEC00	0.3500	0.3500	L01	
		01JAN01	31DEC01	0.9300	0.9300	L01	
		01JAN02	31DEC02	0.3120	0.3120	L01	
		01JAN03	31DEC03	0.7220	0.7220	L01	
		01JAN04	31DEC04	0.9610	0.9610	L01	
		01JAN05	31DEC05	1.2400	1.2400	L01	
		01JAN06	31DEC06	0.7500	0.7500	L01	
	DOC	18JUN84	08SEP88	1.0000	1.0000	L02	
		09SEP88	08JAN95	0.1450	0.1450	L02	
		09JAN95	12DEC95	0.2800	0.2800	L02	<<
	FSS	01JAN02	31DEC02	1.6240	1.6240	L01	
		01JAN03	31DEC03	1.0100	1.0100	L01	
		01JAN04	31DEC04	1.6300	1.6300	L01	
		01JAN05	31DEC05	1.2700	1.2700	L01	
		01JAN06	31DEC06	1.4900	1.4900	L01	
	NH4F	18JUN84	21MAY85	0.0100	0.0100	L01	
		22MAY85	08JAN95	0.0020	0.0056	L01	
		09JAN95	24MAR96	0.0016	0.0056	L01	
		25MAR96	13JAN97	0.0025	0.0056	L01	
		14JAN97	11MAY97	0.0013	0.0013	L01	
		12MAY97	31DEC97	0.0016	0.0016	L01	
		01JAN98	31DEC98	0.0007	0.0007	L01	
		01JAN99	31DEC99	0.0006	0.0006	L01	
		01JAN00	30APR00	0.0015	0.0015	L01	
		01MAY00	31DEC00	0.0015	0.0015	L01	
		01JAN01	31DEC01	0.0017	0.0017	L01	
		01JAN02	28DEC03	0.0015	0.0015	L01	
		01MAR03	31DEC03	0.0015	0.0015	L01	
		01JAN04	31DEC04	0.0004	0.0004	L01	
		01JAN05	31DEC05	0.0029	0.0029	L01	
		01JAN06	31DEC06	0.0026	0.0026	L01	
	NO23F	18JUN84	31JAN86	0.0100	0.0100	L01	
		01FEB86	28APR86	0.0050	0.0100	L01	
		25MAR86	20JUN88	0.0050	0.0050	L01	
		06JUL88	06JUL88	0.0050	0.0025	L01	
		18JUL88	08JAN95	0.0025	0.0025	L01	
		09JAN95	22JAN96	0.0006	0.0025	L01	
		23JAN96	13JAN97	0.0007	0.0025	L01	
		14JAN97	31DEC97	0.0004	0.0004	L01	
		01JAN98	31DEC98	0.0002	0.0002	L01	
		01JAN99	31DEC99	0.0003	0.0003	L01	
		01JAN00	30APR00	0.0001	0.0001	L01	
		01MAY00	31DEC00	0.0001	0.0001	L01	
		01JAN01	31DEC01	0.0002	0.0002	L01	
		01JAN02	31DEC02	0.0003	0.0003	L01	
		01JAN03	31DEC03	0.0004	0.0004	L01	
		01JAN04	31DEC04	0.0001	0.0001	L01	
		01JAN05	31DEC05	0.0002	0.0002	L01	
		01JAN06	31DEC06	0.0004	0.0004	L01	
	NO2F	18JUN84	08JAN95	0.0004	0.0010	L02	

Table A3-3a. A chronology of analytical methods and their detection limits in the CBP main Bay water quality monitoring programs.

Lab	Param	Start	End	Reported	Actual	Method	Chng?
AMRL/ODU NO2F	cont.	09JAN95	07APR96	0.0010	0.0010	L02	
		08APR96	03APR97	0.0004	0.0010	L02	
		04APR97	30APR97	0.0004	0.0004	L02	
		01MAY97	31DEC97	0.0002	0.0002	L01	<
		01JAN98	31DEC98	0.0008	0.0008	L01	
		01JAN99	31DEC99	0.0001	0.0001	L01	
		01JAN00	30APR00	0.0006	0.0006	L01	
		01MAY00	31DEC00	0.0006	0.0006	L01	
		01JAN01	31DEC01	0.0002	0.0002	L01	
		01JAN02	31DEC02	0.0001	0.0001	L01	
		01JAN03	31DEC03	0.0003	0.0003	L01	
		01JAN04	31DEC04	0.0002	0.0002	L01	
		01JAN05	31DEC05	0.0000	0.0000	L01	
		01JAN06	31DEC06	0.0002	0.0002	L01	
	PC	18JUN84	04OCT87	.	.	D01	
		05OCT87	10JUL91	0.1300	0.2400	L01	<
		11JUL91	08JAN95	0.1300	0.1300	L01	
		09JAN95	23MAR96	0.1590	0.1300	L01	
		24MAR96	10JUL96	0.1961	0.1961	L01	
		11JUL96	13JAN97	0.1118	0.1300	L01	
		14JAN97	31DEC97	0.0770	0.0770	L01	
		01JAN98	31DEC98	0.0615	0.0615	L01	
		01JAN99	31DEC99	0.1929	0.1929	L01	
		01JAN00	30APR00	0.1290	0.1290	L01	
		01MAY00	31DEC00	0.1290	0.1290	L01	
		01JAN01	30APR01	0.0670	0.0670	L01	
		01MAY01	31DEC01	0.1833	0.1833	L01	
		01JAN02	31DEC02	0.0831	0.0831	L01	
		01JAN03	31DEC03	0.0930	0.0930	L01	
		01JAN04	31DEC04	0.0710	0.0710	L01	
		01JAN05	31DEC05	0.0990	0.0990	L01	
		01JAN06	31DEC06	0.0870	0.0870	L01	
	PHEO	27JUN84	16NOV84	0.8000	0.0000	L02	
		11DEC84	08JAN95	0.8000	0.0000	L01	<
		09JAN95	10JUL96	0.9600	0.0000	L01	
		11JUL96	13JAN97	0.7500	0.0000	L01	
		14JAN97	31DEC97	1.0700	0.0000	L01	
		01JAN98	31DEC98	1.6400	1.6000	L01	
		01JAN99	31DEC99	0.5900	0.5900	L01	
		01JAN00	30APR00	0.2900	0.2900	L01	
		01MAY00	31DEC00	0.2900	0.2900	L01	
		01JAN01	31DEC01	0.5500	0.5500	L01	
		01JAN02	31DEC02	0.6350	0.6350	L01	
		01JAN03	31DEC03	0.7080	0.7080	L01	
		01JAN04	31DEC04	0.6020	0.6020	L01	
		01JAN05	31DEC05	0.6900	0.6900	L01	
		01JAN06	31DEC06	0.2400	0.2400	L01	
	PN	18JUN84	04OCT87	.	.	D01	
		05OCT87	30OCT90	0.0360	0.0500	L01	<
		05OCT87	08JAN95	0.0360	0.0360	L01	
		09JAN95	23MAR96	0.0260	0.0360	L01	
		24MAR96	13JAN97	0.0414	0.0360	L01	
		14JAN97	31DEC97	0.0090	0.0090	L01	
		01JAN98	31DEC98	0.0070	0.0070	L01	
		01JAN99	31DEC99	0.0276	0.0276	L01	
		01JAN00	30APR00	0.0270	0.0270	L01	
		01MAY00	31DEC00	0.0270	0.0270	L01	
		01JAN01	30APR01	0.0120	0.0120	L01	
		01MAY01	31DEC01	0.0340	0.0340	L01	
		01JAN02	31DEC02	0.0111	0.0111	L01	
		01JAN03	31DEC03	0.0240	0.0240	L01	
		01JAN04	31DEC04	0.0460	0.0460	L01	
		01JAN05	31DEC05	0.0350	0.0350	L01	

Table A3-3a. A chronology of analytical methods and their detection limits in the CBP main Bay water quality monitoring programs.

Lab	Param	Start	End	Reported	Actual	Method	Chng?	
AMRL/ODU	PN cont. PO4F	01JAN06	31DEC06	0.0170	0.0170	L01		
		18JUN84	30NOV85	0.0100	0.0100	L03		
		01DEC85	07DEC86	0.0050	0.0100	L03		
		08DEC86	08JAN95	0.0030	0.0050	L03		
		09JAN95	12MAR96	0.0035	0.0050	L03		
		13MAR96	30DEC96	0.0018	0.0050	L03		
		01JAN97	30APR97	0.0018	0.0010	L03		
		01MAY97	31DEC97	0.0003	0.0003	L02	<	
		01JAN98	31DEC98	0.0009	0.0009	L01	<	
		01JAN99	31DEC99	0.0007	0.0007	L01		
		01JAN00	30APR00	0.0002	0.0002	L01		
		01MAY00	31DEC00	0.0002	0.0002	L01		
		01JAN01	31DEC01	0.0005	0.0005	L01		
		01JAN02	31DEC02	0.0005	0.0005	L01		
		01JAN03	31DEC03	0.0003	0.0003	L01		
		01JAN04	31DEC04	0.0006	0.0006	L01		
	01JAN05	31DEC05	0.0007	0.0007	L01			
	01JAN06	31DEC06	0.0002	0.0002	L01			
	PP		18JUN84	04OCT87	.	.	D01	
			05OCT87	08JAN95	0.0016	0.0070	L01	<
			09JAN95	10JUL96	0.0017	0.0070	L01	
			11JUL96	13JAN97	0.0015	0.0070	L01	
			14JAN97	03MAR97	0.0034	0.0034	L01	
			04MAR97	31DEC98	0.0015	0.0015	L01	
			01JAN99	31DEC99	0.0012	0.0012	L01	
			01JAN00	30APR00	0.0014	0.0014	L01	
			01MAY00	31DEC00	0.0014	0.0014	L01	
			01JAN01	31DEC01	0.0020	0.0020	L01	
			01JAN02	31DEC02	0.0005	0.0005	L01	
			01JAN03	31DEC03	0.0019	0.0019	L01	
			01JAN04	31DEC04	0.0014	0.0014	L01	
			01JAN05	31DEC05	0.0012	0.0012	L01	
		01JAN06	31DEC06	0.0006	0.0006	L01		
SIF			14JUL84	26MAY86	0.0280	0.0280	L01	
		10JUN86	22JAN96	0.0000	0.0230	L01		
		23JAN96	13JAN97	0.0013	0.0230	L01		
		14JAN97	31DEC97	0.0011	0.0011	L01		
		01JAN98	31DEC98	0.0006	0.0006	L01		
		01JAN99	31DEC99	0.0015	0.0015	L01		
		01JAN00	30APR00	0.0004	0.0004	L01		
		01MAY00	31DEC00	0.0004	0.0004	L01		
		01JAN01	31DEC01	0.0010	0.0010	L01		
		01JAN02	31DEC02	0.0016	0.0016	L01		
		01JAN03	31DEC03	0.0006	0.0006	L01		
		01JAN04	31DEC04	0.0019	0.0019	L01		
		01JAN05	31DEC05	0.0006	0.0006	L01		
		01JAN06	31DEC06	0.0013	0.0013	L01		
	TDN		04JUN84	04OCT87	.	.	D01, D02	
			05OCT87	13AUG90	0.0500	0.0500	L01	<
		14AUG90	08JAN95	0.0250	0.0250	L01		
		09JAN95	15MAY96	0.0230	0.0230	L01		
		16MAY96	13JAN97	0.0174	0.0174	L01		
		14JAN97	31DEC97	0.0093	0.0093	L01		
		01JAN98	31DEC98	0.0096	0.0096	L01		
		01JAN99	31DEC99	0.0093	0.0093	L01		
		01JAN00	30APR00	0.0230	0.0230	L01		
		01MAY00	31DEC00	0.0230	0.0230	L01		
		01JAN01	31DEC01	0.0250	0.0250	L01		
		01JAN02	31DEC02	0.0220	0.0220	L01		
		01JAN03	31DEC03	0.0386	0.0386	L01		
		01JAN04	31DEC04	0.0146	0.0146	L01		
		01JAN05	31DEC05	0.0250	0.0250	L01		
		01JAN06	31DEC06	0.0100	0.0100	L01		



Table A3-3a. A chronology of analytical methods and their detection limits in the CBP main Bay water quality monitoring programs.

Lab	Param	Start	End	Reported	Actual	Method	Chng?		
AMRL/ODU	TDP	18JUN84	30NOV85	0.0100	0.0100	L03			
		01DEC85	05JAN87	0.0050	0.0100	L03			
		06JAN87	08JAN95	0.0038	0.0050	L03			
		09JAN95	22JAN96	0.0036	0.0050	L03			
		23JAN96	30DEC96	0.0024	0.0050	L03			
		01JAN97	30APR97	0.0024	0.0020	L03			
		01MAY97	30JUN97	0.0024	0.0024	L03			
		01JUL97	31DEC97	0.0017	0.0017	L01	<		
		01JAN98	31DEC98	0.0010	0.0010	L01			
		01JAN99	31DEC99	0.0020	0.0020	L01			
		01JAN00	30APR00	0.0011	0.0011	L01			
		01MAY00	31DEC00	0.0011	0.0011	L01			
		01JAN01	31DEC01	0.0014	0.0014	L01			
		01JAN02	31DEC02	0.0008	0.0008	L01			
		01JAN03	31DEC03	0.0010	0.0010	L01			
		01JAN04	31DEC04	0.0011	0.0011	L01			
		01JAN05	31DEC05	0.0007	0.0007	L01			
		01JAN06	31DEC06	0.0020	0.0020	L01			
			TKNF	18JUN84	14DEC87	0.1000	0.1000	L02	<<
			TKNW	18JUN84	14DEC87	0.1000	0.1000	L02	<<
			TOC	18JUN84	14DEC87	1.0000	1.0000	L02	<<
				05DEC87	.	.	.	D01	<
			TP	18JUN84	14DEC87	0.0100	0.0100	L03	<<
				15DEC87	.	.	.	D01	<
			TSS	18JUN84	30JUN92	2.0000	4.0000	L01	
				01JUL93	08JAN95	2.0000	2.0000	L01	
				09JAN95	08MAY95	2.9000	2.9000	L01	
				09MAY95	09JUL96	1.2000	1.2000	L01	
				10JUL96	11MAY97	1.9000	1.9000	L01	
				12MAY97	31DEC97	2.7000	2.7000	L01	
				01JAN98	31DEC98	3.3000	3.3000	L01	
				01JAN99	31DEC99	2.2000	2.2000	L01	
				01JAN00	30APR00	1.9500	1.9500	L01	
	01MAY00	31DEC00		1.9500	1.9500	L01			
	01JAN01	31DEC01		1.7000	1.7000	L01			
	01JAN02	31DEC02		1.6980	1.6980	L01			
	01JAN03	31DEC03		1.0010	1.0010	L01			
	01JAN04	31DEC04		1.4400	1.4400	L01			
	01JAN05	31DEC05		0.9800	0.9800	L01			
	01JAN06	31DEC06	2.1400	2.1400	L01				
	VSS	01JAN02	31DEC02	0.4070	0.4070	L01			
		01JAN03	31DEC03	0.4110	0.4110	L01			
		01JAN04	31DEC04	0.4000	0.4000	L01			
		01JAN05	31DEC05	0.3600	0.3600	L01			
<u>UMD Chesapeake Biological Lab (CBL, MDDNR)</u>									
CBL	BIOSI	07MAR94	30JAN04	0.0090	.	L01	<<		
		16AUG97	31OCT97	1.0000	1.0000	L03	<<< (MDHMH)		
	DOC	16MAY85	19SEP88	0.5000	0.5000	L01			
		20SEP88	31DEC95	0.2400	0.2400	L01			
		31JAN04	31DEC06	0.1500	.	L01			
			01JAN07	.	0.2400	L01			
	NH4F	01MAR85	31JAN02	0.0030	0.0030	L01			
		31JAN04	31DEC06	0.0030	.	L01			
		01JAN07	.	.	0.0030	L01			
	NO23F	01MAR85	30SEP87	0.0009	0.0009	L01			
		01OCT87	19SEP88	0.0002	0.0002	L01			
		20SEP88	31JAN02	0.0002	0.0002	L01			
		31JAN04	31DEC06	0.0007	.	L01			
		01JAN07	.	.	0.0007	L01			
	NO2F	01MAR85	30SEP87	0.0005	0.0005	L01			
		01OCT87	19SEP88	0.0002	0.0002	L01			
		20SEP88	31JAN02	0.0002	0.0002	L01			
		31JAN04	.	0.0003	.	L01			

Table A3-3a. A chronology of analytical methods and their detection limits in the CBP main Bay water quality monitoring programs.

Lab	Param	Start	End	Reported	Actual	Method	Chng?	
CBL	NO2F cont.	01JAN07	.	.	0.0006	L01		
		20MAY85	24SEP86	0.0010	0.5000	L01		
	PC	05OCT87	19SEP88	0.0010	0.0010	L01		
		20SEP88	31JAN02	0.0630	0.0633	L01		
		31JAN04	.	0.0759	0.0633	L01		
	PHEO	16AUG97	31OCT97	1.0000	0.5000	L03		
		01JAN07	.	.	0.2300	L01	<	
	PIP	07MAR94	13OCT94	0.0006	0.0006	L01		
		31JAN04	.	0.0006	0.0024	L01		
	PN	16MAY85	24SEP86	0.0010	0.0500	L01		
		05OCT87	19SEP88	0.0010	0.0010	L01		
		20SEP88	31JAN02	0.0105	0.0105	L01		
	PO4F	31JAN04	.	0.0123	0.0105	L01		
		16MAY85	30SEP87	0.0016	0.0016	L01		
		01OCT87	31JAN02	0.0006	0.0006	L01		
	PP	31JAN04	.	0.0007	0.0006	L01		
		16MAY85	30SEP86	0.0013	0.0013	L01		
		01OCT87	31JAN02	0.0012	0.0012	L01		
	SIF	31JAN04	31DEC06	0.0024	0.0024	L01		
		01JAN07	.	.	0.0054	L01		
		16MAY85	31MAR87	0.0120	0.0120	L01		
	TDN	01APR87	31JAN02	0.0100	0.0100	L01		
		31JAN04	31DEC06	0.0100	0.1000	L01		
		01JAN07	30JUN08	.	0.0800	L01		
	TDP	01JUL08	30JUN09	.	0.0100	L01		
		16MAY85	30SEP86	0.0300	0.0300	L01		
		01OCT87	31JAN02	0.0200	0.0200	L01		
	TKNF	31JAN04	31DEC06	0.0300	.	L01		
		01JAN07	.	.	0.0200	L01		
		16MAY85	30SEP86	0.0050	0.0050	L01		
	TKNW	01OCT86	30SEP87	0.0120	0.0120	L01		
		01OCT87	31JAN02	0.0010	0.0010	L01		
		31JAN04	31DEC06	0.0015	0.0010	L01		
	TOC	01JAN07	.	.	0.0015	L01		
		01JUN86	30SEP87	0.2000	0.1000	L01	<<	
		01JUN86	30SEP87	0.2000	0.2000	L01	<<	
	TP	01OCT86	30SEP87	1.0000	1.0000	L01	<<	
		01OCT87	.	.	.	D01	<	
		01OCT87	.	.	.	D01	<	
	TSS	01OCT86	30SEP87	0.0120	0.0120	L01	<<	
		01OCT87	.	.	.	D01	<	
		16MAY85	30SEP87	1.0000	4.0000	L01		
	VSS	01OCT87	19SEP88	1.9800	2.0000	L01		
		20SEP88	31JAN02	1.5000	2.4000	L01		
		31JAN04	.	2.4000	2.4000	L01		
	VSS	01JUN99	31DEC06	1.9800	1.9800	L01		
		01JAN07	.	.	0.9000	APHA('75)	<	
	<u>USEPA Central Regional Lab (CRL, MDDNR)</u>							
	CRL	CHLA	01JUL84	15MAY85	1.0000	1.0000	L01	<<< (CBL)
		DOC	01JUL84	15MAY85	1.0000	1.0000	L01	<<< (CBL)
		NH4F	01JUL84	31JAN85	0.0200	0.0200	L01	
			01FEB85	28FEB85	0.0400	0.0400	L01	<<< (CBL)
		NO23F	01JUL84	28FEB85	0.0400	0.0400	L01	<<< (CBL)
		NO2F	01JUL84	28FEB85	0.0100	0.0100	L01	<<< (CBL)
PHEO		01JUL84	15MAY85	1.0000	1.0000	L01	<<< (CBL)	
PO4F		01JUL84	28FEB85	0.0070	0.0070	L01		
		01MAR85	15MAY85	0.0016	0.0016	L01	<<< (CBL)	
SIF		01JUL84	28FEB85	0.1000	0.1000	L01		

Table A3-3a. A chronology of analytical methods and their detection limits in the CBP main Bay water quality monitoring programs.

Lab	Param	Start	End	Reported	Actual	Method	Chng?		
CRL	SIF cont.	01MAR85	15MAY85	0.0120	0.0120	L01	<<< (CBL)		
		01JUL84	31JAN85	0.0120	0.0120	L01			
	TDP	01FEB85	28FEB85	0.0100	0.0100	L01			
		01MAR85	15MAY85	0.0050	0.0050	L01	<<< (CBL)		
	TKNF	01JUL84	15MAY85	0.2000	0.3750	L01	<<< (CBL)		
	TKNW	01JUL84	15MAY85	0.2000	0.2000	L01	<<< (CBL)		
	TOC	01JUL84	15MAY85	1.0000	1.0000	L01	<<< (CBL)		
	TP	01JUL84	31JAN85	0.0120	0.0120	L01			
		01FEB85	28FEB85	0.0100	0.0100	L01			
	TSS	01MAR85	15MAY85	0.0050	0.0050	L01	<<< (CBL)		
		01JUL84	15MAY85	4.0000	4.0000	L01	<<< (CBL)		
<u>MD Dept of Health and Mental Hygiene (MDHMH, MDDNR)</u>									
MDHMH	CHLA	16MAY85	30SEP87	0.0100	1.0000	L01			
		01OCT87	15AUG97	1.0000	1.0000	L01			
		01NOV97	31JAN02	1.0000	0.0100	L01			
		01JAN07	.	.	0.1000	APHA ('81) <, <<< (CBL)			
	PHEO	16MAY85	30SEP87	0.0100	1.0000	L01			
		01OCT87	15AUG97	1.0000	1.0000	L01			
		01NOV97	31JAN02	1.0000	1.0000	L01			
		01JAN07	.	.	0.1000	APHA ('81) <, <<< (CBL)			
		<u>VA Institute of Marine Science, College of William &amp; Mary (VIMS, VIMS)</u>							
		VIMS	BIOSI	07MAR94	19OCT94	0.1000	0.1000	L01	<<
				27JUN84	31MAY89	1.0000	1.0000	L01	
CHLA	01JUN89		30JUN90	3.2000	3.2000	L01			
	01JUL90		13DEC95	1.3200	1.3200	L01	<<< (AMRL)		
	27JUN84		31AUG88	1.0000	1.4000	L02			
DOC	01SEP88		30JUN90	0.5000	0.5000	L02			
	01JUL90		13JUN95	0.3600	0.3600	L02	<<< (AMRL)		
NH4F	27JUN84		30SEP86	0.0200	0.0200	L01			
	01OCT86		30APR88	0.0100	0.0100	L01			
	01MAY88		31MAY89	0.0130	0.0130	L01			
	01JUN89		30JUN90	0.0100	0.0100	L01			
	01JUL90		13DEC95	0.0040	0.0040	L01	<<< (AMRL)		
NO23F	27JUN84		30SEP86	0.0200	0.0200	L01			
	01OCT86		30APR88	0.0100	0.0100	L01			
	01MAY88		31MAY89	0.0014	0.0014	L01			
	01JUN89		30JUN90	0.0021	0.0021	L01			
	01JUL90		13DEC95	0.0024	0.0024	L01	<<< (AMRL)		
NO2F	27JUN84		30APR88	0.0040	0.0040	L01			
	01MAY88		31MAY89	0.0008	0.0008	L01			
	01JUN89		30JUN90	0.0015	0.0015	L01			
	01JUL90		13DEC95	0.0006	0.0006	L01	<<< (AMRL)		
PC	27JUN84		04OCT87	.	.	D01			
	05OCT87		30APR88	0.5810	0.5810	L01	<		
	01MAY88		31MAY89	0.0990	0.0990	L01			
	01JUN89		30JUN90	0.1040	0.1040	L01			
	01JUL90		13DEC95	0.0970	0.0970	L01	<<< (AMRL)		
PHEO	27JUN84		26NOV84	1.0000	0.0000	L02			
	10DEC84		13DEC95	1.0000	0.0000	L01	<, <<< (AMRL)		
PIP	07MAR94		19OCT94	0.0012	0.0012	L01	<<		
PN	27JUN84		04OCT87	.	.	D01			
	05OCT87		30APR88	0.0240	0.0240	L01	<		
	01MAY88		31MAY89	0.0260	0.0260	L01			
	01JUN89		30JUN90	0.0290	0.0290	L01			
	01JUL90		13DEC95	0.0190	0.0190	L01	<<< (AMRL)		
	27JUN84		03DEC87	0.0100	0.0100	L02			
	01JAN88		31DEC88	0.0005	0.0005	L01	<		
PO4F	01JAN89		31DEC89	0.0030	0.0030	L01			
	01JAN90		31DEC90	0.0006	0.0030	L01			
	01JAN91		31DEC91	0.0008	0.0006	L01			
	01JAN92		31DEC95	0.0020	0.0050	L01	<<< (AMRL)		
	27JUN84		04OCT87	.	.	D01			

Table A3-3a. A chronology of analytical methods and their detection limits in the CBP main Bay water quality monitoring programs.

Lab	Param	Start	End	Reported	Actual	Method	Chng?
VIMS	PP cont	16NOV87	30APR88	0.0100	0.0100	L01	<
		01MAY88	31MAY89	0.0010	0.0010	L01	
	SIF	01JUN89	13DEC95	0.0030	0.0030	L01	<<< (AMRL)
		27JUN84	30APR88	0.0560	0.0560	L01	
		01MAY88	31MAY89	0.0090	0.0090	L01	
		01JUN89	30JUN90	0.0070	0.0070	L01	
	TDN	01JUL90	14DEC95	0.0130	0.0130	L01	<<< (AMRL)
		27JUN84	04OCT87	.	.	D01	
		05OCT87	30APR88	0.1000	0.1000	L01	<
		01MAY88	31MAY89	0.0450	0.0450	L01	
	TDP	01JUN89	30JUN90	0.0400	0.0400	L01	
		01JUL90	13DEC95	0.0260	0.0750	L01	<<< (AMRL)
		27JUN84	31DEC87	0.0100	0.0100	L02	
		06JAN88	08DEC88	0.0060	0.0090	L01	<
	TKNF	04JAN89	13DEC89	0.0050	0.0060	L01	
		01JAN90	31DEC95	0.0020	0.0050	L01	<<< (AMRL)
	TKNW	27JUN84	18DEC87	0.1000	0.1000	L01	<<
		27JUN84	18DEC87	0.1000	0.1000	L01	<<
	TOC	27JUN84	18DEC87	1.0000	1.4000	L01	
		19DEC87	31DEC95	.	.	D01	<<< (AMRL)
TP	27JUN84	18DEC87	0.0100	0.0090	L02		
	19DEC87	31DEC95	.	.	D01	<, <<< (AMRL)	
TSS	27JUN84	30APR88	4.0000	4.0000	L01		
	01MAY88	13DEC95	5.0000	2.0000	L01	<<< (AMRL)	

Last updated in 2006-07.

- < indicates method change within laboratory;
- << indicates parameter, as such, discontinued within the Program component (i.e., main Bay vs tributary monitoring program component)
- <<< indicates sample analysis for the parameter no longer done by this laboratory for this monitoring component (main Bay vs tributary program)

Table A3-3b. A chronology of analytical methods and their detection limits in the CBP tributary water quality monitoring programs.

Lab	Param	Start	End	Reported	Actual	Method	Chng?
-----	-------	-------	-----	----------	--------	--------	-------

PIP		01JAN04	03JAN07	.	0.0008		
<u>Blue Plains field laboratory (BPFL, DCDOH)</u>							
BPFL	HARDNESS	23JAN84	15DEC98	.	.	L01	
	TALK	23JAN84	15DEC98	10.0000	.	L01	
	TURB_NTU	23JAN84	15DEC98	0.0000	.	L01	
<u>UMD Chesapeake Biological Lab (CBL, MDDNR)</u>							
CBL	BIOSI	01MAR94	31OCT94	0.0090	0.0090	L01	<<
	CHLA	01JAN09	.	0.6200	0.6200	L01	
	DOC	01MAY92	30SEP95	0.2400	0.2400	L03	
		01JAN98	31DEC03	0.2400	0.2400	L01	<
		31JAN04	31DEC06	0.1500	.	L01	
		01JAN07	.	.	0.2400	L01	
	NH4F	01JUL90	27APR98	0.0030	0.0030	L01	
		14MAY98	31DEC01	0.0030	0.0030	L01	
		31JAN04	31DEC06	0.0030	.	L01	
		01JAN07	31DEC08	.	0.0030	L01	
		01JAN09	.	0.0060	0.0060	L01	
	NO23F	01JUL90	27APR98	0.0002	0.0002	L01	
		01MAY98	31DEC01	0.0002	0.0002	L01	
		31JAN04	31DEC06	0.0007	.	L01	
		01JAN07	.	.	0.0007	L01/L03	<
	NO2F	01JUL90	27APR98	0.0002	0.0002	L01	
		06MAY98	31DEC01	0.0002	0.0002	L01	
		31JAN04	31DEC06	0.0003	.	L01	
		01JAN07	31DEC08	.	0.0006	L01	
		01JAN09	.	0.0001	0.0001	L01	
	PC	12JUL90	27APR98	0.0630	0.0630	L01	
		01MAY98	31DEC01	0.0630	0.0630	L01	
		31JAN04	.	0.0759	0.0633	L01	
		01JAN07	.	.	0.0633	L01	<
	PHEO	01JAN07	31DEC08	.	0.2300	L01	
		01JAN09	.	0.7400	0.7400	L01	
	PIP	14MAR94	05OCT94	0.0006	0.0006	L01	<<
		31JAN04	.	0.0006	0.0024	L01	
		01JAN07	.	.	0.0024	L01	
	PN	12JUL90	27APR98	0.0105	0.0105	L01	
		04MAY98	19DEC01	0.0105	0.0105	L01	
		31JAN04	.	0.0123	0.0105	L01	
		01JAN07	.	.	0.0105	L01	
	PO4F	01JUL90	27APR98	0.0006	0.0040	L01	
		11MAY98	31DEC01	0.0006	0.0006	L01	
		31JAN04	.	0.0007	0.0006	L01	
		01JAN07	.	.	0.0006	L01	
	PP	01APR92	27APR98	0.0012	0.0012	L01	
		01MAY98	19DEC01	0.0012	0.0024	L01	
		31JAN04	31DEC06	0.0024	0.0024	L01	
		01JAN07	.	.	0.0054	L01	
	SIF	12JUL90	28APR98	0.0100	0.0100	L01	
		04MAY98	20DEC01	.	0.1000	L01	
		31JAN04	31DEC06	0.0100	0.1000	L01	
		01JAN07	30JUN08	.	0.0800	L01	
		01JUL08	30JUN09	.	0.0100	L01	
	SIW	07JUN00	31DEC01	0.1000	0.1000	L01	
	TALK	01JUN98	22MAY00	0.1000	0.1000	L01	
	TDN	12JUL90	27APR98	0.0200	0.0200	L01	
		01MAY98	20DEC01	0.0200	0.0200	L01	
		31JAN04	31DEC06	0.0300	.	L01	
		01JAN07	.	.	0.0200	L01	
	TDP	12JUL90	27APR98	0.0010	0.0100	L01	
		01MAY98	20DEC01	0.0010	0.0010	L01	
		01JAN07	.	.	0.0015	L01	
	TOC	01JUL98	.	.	.	L03	

Table A3-3b. A chronology of analytical methods and their detection limits in the CBP tributary water quality monitoring programs.

Lab	Param	Start	End	Reported	Actual	Method	Chng?	
CBL	TP	01JAN97	28FEB98	.	0.0100	L01		
		01MAR98		.	.	D01	<	
	TSS	01JUL90	27APR98	1.5000	1.5000	L01		
		01MAY98	19DEC03	1.5000	2.4000	L01		
		31JAN04	.	2.4000	2.4000	L01		
	TURB_NTU	01JAN07	.	.	2.4000	L01	<	
		01JUN98	22MAY00	.	.	L01		
	VSS	31JAN04	31DEC06	1.9800	1.9800	L01		
		01JAN07	.	.	0.9000	APHA('75)	<	
	<u>DC Dept of Health Environmental Laboratory/Branch at USEPA CRL (ELB, DCDOH)</u>							
ELB	BOD5W	23JAN84	15DEC98	1.0000	1.0000	L01		
		25JAN84	17NOV86	1.0000	1.0000	L01		
	DOC	21FEB84	14MAY85	.	1.0000	L01		
		10JUN85	11SEP90	.	1.0000	L02	<	
		15OCT90	05APR94	.	1.0000	L01	<	
	FCOLI	21FEB84	30APR90	20.0000	20.0000	L01		
		14MAY90	30APR92	20.0000	20.0000	L02	<	
		01MAY92	04NOV96	20.0000	20.0000	L01	<	
	NH4F	23JAN84	17DEC84	0.0400	0.0200	L01		
		15APR85	14DEC98	0.0400	0.0400	L01		
	NO23F	07AUG95	15DEC98	0.0400	0.0400	L01		
	NO2F	23JAN84	24JUL95	0.0100	0.0100	L01		
	PHEO	25JAN84	17NOV86	1.0000	1.0000	L01		
	PO4F	23JAN84	31MAR91	0.0050	0.0070	L01		
		01APR91	21SEP92	0.0050	0.0050	L01		
		26OCT92	23AUG93	0.0050	0.0100	L01		
		24AUG93	15DEC98	0.0050	0.0050	L01		
	SIF	23JAN84	13JUN84	.	.	L01		
		18JUN84	18SEP90	.	0.1000	L01		
		01OCT90	24JUL95	.	0.2000	L01		
	TCOLI	21FEB84	31MAR90	20.0000	20.0000	L01		
		01APR90	30APR92	20.0000	20.0000	L02	<	
		01MAY92	14DEC98	20.0000	20.0000	L01	<	
	TDP	23JAN84	15DEC92	0.0100	0.0100	L05		
	TKNW	23JAN84	28SEP93	0.2000	0.2000	L02		
	TOC	21FEB84	05APR94	.	1.0000	L01		
	TP	23JAN84	15DEC92	0.0100	0.0100	L01		
	TSS	23JAN84	15DEC98	1.0000	4.0000	L01		
	<u>MD Dept of Health and Mental Hygiene (MDHMH, MDDNR)<sup>3</sup></u>							
	MDHMH	BIOSI	01MAR94	31OCT94	0.0900	0.0900	L01	<<
			01JAN86	11JUL94	2.0000	0.5000	L01	
		BOD5W	12JUL94	31DEC01	2.0000	2.0000	L01	
			01JUL84	29JAN86	0.0100	0.0100	L02	
08FEB86			31DEC01	0.0100	1.0000	L01	<	
DOC		01JAN07	.	.	0.1000	APHA('81)	<	
		01NOV84	31DEC88	1.0000	2.0000	L03		
		01JAN89	30APR90	0.8000	0.8000	L03		
		01MAY90	05APR94	0.5000	0.5000	L03		
FCOLI		06APR94	11DEC97	0.5000	0.5000	L01	<	
		01JAN98	31DEC98	.	.	L01		
		01JAN86	31AUG90	3.0000	3.0000	L01		
NH4F		01SEP90	15MAY00	2.0000	2.0000	L01		
		01JUL84	31MAY86	0.0200	0.0200	L01		
NH4W		01JUN86	23APR98	0.0080	0.0080	L01		
		01JUN85	31MAY86	0.0200	0.0200	L01		
NO23F		01JUN86	30JUN05	0.0080	0.0080	L01		
		01JUL84	23APR98	0.0200	0.0200	L01		
NO23W		02AUG84	31DEC01	0.0200	0.0200	L01		
NO2F		01JUL84	23APR98	0.0020	0.0020	L01		
NO2W		02AUG84	31DEC01	0.0020	0.0020	L01		
PHEO		01JUL84	30JAN86	0.0100	0.0100	L02		

Table A3-3b. A chronology of analytical methods and their detection limits in the CBP tributary water quality monitoring programs.

Lab	Param	Start	End	Reported	Actual	Method	Chng?
-----	-------	-------	-----	----------	--------	--------	-------

MDHMH	PHEO cont.	31JAN86	31DEC01	.	1.0000	L01	<
		01JAN07	.	.	0.1000	APHA('81)	<
	PIP	07MAR94	27OCT94	0.0006	0.0006	L01	
	PO4F	01JUL84	31MAY86	0.0100	0.0100	L01	
		01JUN86	23APR98	0.0040	0.0040	L01	
	PO4W	02AUG84	12DEC01	0.0040	0.0040	L01	
	SIF	01NOV84	23APR98	0.1000	0.1000	L01	
	SIW	26FEB85	04MAY00	0.1000	0.1000	L01	
	TALK	01JAN86	30JUN94	.	1.0000	L01	
		01JUL94	31DEC01	0.1000	0.1000	L01	
	TCOLI	01JAN86	31AUG90	3.0000	3.0000	L01	
		01SEP90	14APR98	2.0000	1.8000	L01	
	TDP	16OCT84	23APR87	0.0100	0.0100	L01	
	TKNF	01AUG84	31MAY92	0.1000	0.1000	L02	
		01JUN92	23APR98	0.1000	0.1000	L02	
	TKNW	01JUL84	29APR98	0.1000	0.1000	L02	
		01MAY98	31DEC01	0.1000	0.1000	L02	
	TOC	01JUL84	31DEC88	1.0000	1.0000	L03	
		01JAN89	30APR90	0.8000	0.8000	L03	
		01MAY90	31MAY92	0.5000	0.5000	L03	
		01JUN92	31DEC01	0.5000	0.5000	L03	
	TP	01JUL84	30JUN98	0.0100	0.0100	L01	
		01JUL98	31DEC01	0.0100	0.0100	L01	
	TSS	01JUL84	27APR98	1.0000	1.0000	L01	
		05MAY98	31DEC01	1.0000	1.0000	L01	
	TURB_NTU	06JAN86	30JUN94	.	0.5000	L01	
		01JUL94	20APR98	0.1000	0.1000	L01	
		01MAY98	30MAY00	0.1000	0.1000	L01	
		01JUN00	31DEC01	.	.	L01	
<u>MD Dept of Health and Mental Hygiene - Western (MDHMH-WM, MDDNR)</u>							
MDHMH-WM	FCOLI	08JAN86	31DEC98	.	3.0000	L01	
		09JAN99	05DEC01	2.0000	2.0000	L01	
	TALK	01JAN86	30JUN94	.	0.1000	L01	
		01JUL94	17MAY00	0.1000	0.1000	L01	
	TCOLI	08JAN86	18DEC97	.	3.0000	L01	
	TSS	08JAN86	05DEC01	2.0000	2.0000	L01	
	TURB_NTU	08JAN86	30JUN94	.	0.5000	L01	
		01JUL94	16MAY00	0.1000	0.1000	L01	
<u>St Marys River Project (SMRP, SMCM)</u>							
SMRP	TALK	08JUL99	31DEC03	1.1700	1.1700	L01	
	TSS	27APR99	31DEC03	3.1300	3.1300	L01	
	VSS	15FEB00	31DEC03	2.4700	2.4700	L01	
<u>UMD Center for Environmental Studies-Appalachian Laboratory (UMCES-AL, SMCM)</u>							
UMCES-AL	DOC	01APR99	31DEC03	0.1660	0.1660	L03	
	SO4F	01APR99	31DEC03	0.0190	0.0190	L02	
<u>VA Division of Consolidated Laboratory Services (VADCLA, VADEQ)<sup>2</sup></u>							
VADCLS	BOD4W	02OCT85	12MAR97	1.0000	1.0000	L01	
		12MAR97	24JUN01	2.0000	2.0000	L01	
	CHLA	01OCT98	21JUL04	0.5000	0.5000	L01	
		01JAN04	03JAN07	.	0.5000	L01	
	COD	06APR92	14DEC95	5.0000	5.0000	L01	
	DOC	01JAN04	03JAN07	.	2.0000	L01	
	FS	06JAN98	15DEC99	5.0000	5.0000	L01	
	FSS	23AUG84	14JAN91	5.0000	1.0000	L01	
		27SEP84	08FEB89	0.0000	1.0000	L01	
		01APR88	04MAR91	1.0000	1.0000	L01	
		11APR88	21FEB91	1.0000	5.0000	L01	
		11APR88	04MAR91	1.0000	1.0000	L01	
		15JUN88	01MAY91	5.0000	5.0000	L01	
		04MAR91	03JAN07	3.0000	3.0000	L01	

Table A3-3b. A chronology of analytical methods and their detection limits in the CBP tributary water quality monitoring programs.

Lab	Param	Start	End	Reported	Actual	Method	Chng?
VADCLS	NH4F	11JUL84	23JUN86	0.0100	0.0500	L01	
		11JUL84	30JUN87	0.1000	0.0500	L01	
		09AUG84	10DEC87	0.0500	0.0500	L01	
		01JAN88	13JAN94	0.0400	0.0400	L01	
		14JAN94	03JAN07	0.0040	0.0040	L01	
		01MAY07	.	.	0.0060	L01	
	NH4W	01JAN04	03JAN07	.	0.0400	L01	
	NO23F	21JUL86	21JUL86	0.0500	0.0500	L01	
		11APR96	03JAN07	0.0040	0.0040	L01	
		12MAR97	31DEC97	0.0040	0.0040	C01A	<
		12MAR97	03JAN07	0.0040	0.0040	L01	<
	NO23W	01JAN04	03JAN07	.	0.0400	L01	
	NO2F	14APR84	13JAN94	0.0100	0.0100	L01	
		15FEB94	03JAN07	0.0020	0.0020	L01	
	PC	13FEB95	12DEC01	0.1000	0.1000	L01	
		01MAY07	.	.	0.1000	L01	
	PHEO	01SEP98	21JUL04	0.5000	0.5000	L01	
		01JAN04	03JAN07	.	0.5000	L01	<
	PN	13FEB95	12DEC01	0.0100	0.0100	L01	
		01MAY07	.	.	0.0600	L01	
	PO4F	11JUL84	11JAN94	0.0100	0.0100	L03	
		26JAN94	21JUL04	0.0020	0.0020	L01	<
	PO4W	01JAN04	03JAN07	.	0.0200	L01	
	PP	13FEB95	12DEC01	0.0010	0.0010	L01	
		01MAY07	.	.	0.0032	L01	
	SIF	12JUL84	17SEP85	0.4670	0.4670	L01	
		15JAN86	24APR90	0.0470	0.0470	L01	
		08MAY86	27JUN91	0.0470	0.0470	L01	
		11JUL91	21JUL04	0.0467	.	L01	
		01JAN04	03JAN07	.	0.0467	L01	
	SO4W	01JAN04	31DEC04	.	5.0000	L01	
		01JAN05	03JAN07	.	1.0000	L01	
	TALK	09DEC91	09DEC99	.	.	L01	
	TDN	13FEB95	21JUL04	0.0040	0.0040	L01	
		01JAN04	30APR07	.	0.0040	L01	<
		01MAY07	.	.	0.0110	L01	<
	TDP	11JUL84	01JAN94	0.0100	0.0100	L05	
		13FEB95	21JUL04	0.0010	0.0010	L01	<
		01MAY07	.	.	0.0030	L04	<
	TKNW	16JUL84	27SEP95	0.1000	0.1000	L02	
		09AUG84	27SEP95	0.1000	0.1000	L02	
		04FEB95	04FEB95	.	0.2000	L02	
		01JAN04	03JAN07	.	0.1000	L01	<
	TN	01JAN04	03JAN07	.	0.1000	L01	
	TOC	11JUL84	21MAY96	1.0000	1.0000	L01	
		11JUL84	20AUG96	1.0000	1.0000	L01	
		03MAY88	08AUG96	1.0000	1.0000	L01	
		23JUN98	21JUL98	1.0000	1.0000	L01	
	TP	11JUL84	23NOV93	0.1000	0.0100	L01	
		11JUL84	02DEC93	0.0100	0.0100	L01	
		11JUL84	01JAN94	0.0100	0.0100	L01	
		11JUL84	27SEP95	0.1000	0.0100	L01	
		19APR85	12OCT95	0.0100	0.1000	L01	
		19APR88	01DEC93	0.1000	0.0100	L01	
		01JAN94	27SEP95	0.0020	0.0020	L01	
		10JAN95	12OCT95	0.0020	0.1000	L01	
		01JAN04	03JAN07	.	0.0100	L01	
	TS	06JAN98	15DEC99	5.0000	5.0000	L01	
		14JAN98	09DEC99	5.0000	5.0000	L01	



Table A3-3b. A chronology of analytical methods and their detection limits in the CBP tributary water quality monitoring programs.

Lab	Param	Start	End	Reported	Actual	Method	Chng?	
VADCLS	TSS	23AUG84	30JUN88	5.0000	5.0000	L01		
		19APR88	11DEC96	3.0000	3.0000	L01		
		07JAN97	03JAN07	3.0000	3.0000	L01		
		TURB_FTU	01JAN97	26APR99	?	?	L01	
		TURB_NTU	15DEC92	10DEC01	?	?	L01	
			01JAN02	21JUL04	0.1000	0.1000	L01	
			01JAN04	03JAN07	?	0.1000	L01	
		VSS	23AUG84	18NOV91	1.0000	1.0000	L01	
			23AUG84	11DEC91	3.0000	1.0000	L01	
			19APR88	09DEC91	3.0000	1.0000	L01	
			01JAN02	21JUL04	3.0000	?	L01	
	<u>VA Commonwealth University (VCU, VADEQ)<sup>2</sup></u>							
VCU	CHLA	19JUL88	30JUN91	3.1000	3.1000	L01		
		01JUL91	30SEP98	0.3600	1.0000	L01	<<< (VADCLS)	
	PHEO	18JUL88	30JUN91	3.1000	1.0000	L01		
		01JUL91	01SEP98	0.3600	1.0000	L01	<<< (VADCLS)	
<u>VA Institute of Marine Science, College of William &amp; Mary (VIMS, VIMS)</u>								
VIMS	BIOSI	08FEB94	13DEC94	0.1000	0.1000	L01	<<	
	CHLA	01JAN01	31DEC02	0.5000	0.5000	L03		
	DOC	11JAN94	31DEC94	0.3600	0.3600	L02		
	FSS	01JAN01	31DEC02	2.0000	2.0000	L01		
	NH4F	01JAN01	31DEC02	0.0015	0.0015	L01		
	NO23F	01JAN01	31DEC02	0.0008	0.0008	L01		
	NO2F	01JAN01	31DEC02	0.0002	0.0002	L01		
	PC	11JAN94	01DEC94	0.9600	0.0960	L01		
	PHEO	01JAN01	31DEC02	0.5000	0.5000	L03		
	PIP	08FEB94	13DEC94	0.0010	0.0010	L01		
	PN	11JAN94	01DEC94	0.0180	0.0180	L01		
	PO4F	01JAN01	31DEC02	0.0006	0.0006	L01		
	PP	11JAN94	01DEC94	0.0010	0.0010	L01		
	TDN	11JAN94	01DEC94	0.0260	0.0260	L01		
			01JAN01	31DEC02	0.0340	0.0340	L01	
	TDP	11JAN94	01FEB95	0.0020	0.0020	L02		
			01JAN01	31DEC02	0.0020	0.0020	L01	<
	TSS	01JAN01	31DEC02	2.0000	2.0000	L01		
VSS	01JAN01	31DEC02	2.0000	2.0000	L01			
<u>VA State Water Control Board (VSWCB, VSWCB)<sup>2</sup></u>								
VSWCB	CHLA	18JUN85	18JUL88	3.1000	3.1000	L01	<<< (VCU)	
		18JUN85	18JUL88	3.1000	3.1000	L01	<<< (VCU)	

<sup>1</sup> From 1984 until present. Last updated in 2005.

<sup>2</sup> SWCB became a subordinate agency to Virginia's Department of Environmental Quality (VADEQ) created in 1993. Pigment analysis went to VCU in 1988. In 1998, pigment analysis went to VADCLS.

<sup>3</sup> MDHMH performed water quality analyses on whole water samples thru June 2005.

Thereafter, new equipment allowed analyses on field-filtered samples, consistent with most other CBP-partner laboratories. These parameters, their codes and detection limits are not in this table.

< indicates method change within laboratory;

<< indicates parameter, as such, discontinued within the Program component (i.e., main Bay vs tributary monitoring program component)

<<< indicates sample analysis for the parameter no longer done by this laboratory for this monitoring component (main Bay vs tributary program)

## Appendix 4

### Data Analysis Issues Tracking System (DAITS)

A primary objective of the Chesapeake Bay Program's information management system (CIMS) is to create and maintain a water quality database of *known* quality. Thus documentation and, where possible, resolution of problems with data quality is very important. To insure that all issues receive appropriate attention and to provide thorough documentation of this process for future users, a tracking system was designed which is known as the Data Analysis Issues Tracking System ([DAITS](#)).

DAITS is intended as a central collection point for the registry of all issues that may be raised by those involved in management, operation, data analysis and review of the Chesapeake Bay Program monitoring programs. The system also includes issues relating to any programs contributing data to the CBP water quality database, including historical (pre-1985) datasets.

DAITS provides a way to document issues and achieve consensus on their resolution. Resolution may involve more than one entity, including the various CBP subcommittee workgroups, as well as the data providers. To date, issues have been concentrated in three general categories: those concerning field and laboratory methods and quality assurance data; issues concerning statistics or other data analysis methods; issues concerning data management. DAITS issues need not be limited to these categories or limited in any way. They may be small or large. They need not be fully developed before they are introduced into the system. Issues may be introduced informally by contacting the Water Quality Data Manager, but contributors are strongly urged to use the format provided below as far as possible in order to assist in accomplishing appropriate follow-through.

The documentation for each issue is stored in a computer file. The storage location and retrieval method are currently under review and will change. Please contact the Water Quality Data Manager to obtain access. The following list (Table A4-1) of issue titles is provided to give users an idea of the scope of the issues included to date. In recent years, the number of new issues has dwindled, but the system remains dynamic. Renewed activity is anticipated as the database continues to grow and more users have access to the data.

**Table A4-1. Chesapeake Bay Program Data Analysis Issues Tracking System.**

<b>Issue #</b>	<b>Entry Date</b>	<b>Issue Title</b>
001	05/90	Criteria for data censoring
002	05/90	Adjusting helix Kjeldahl nitrogen data
003	05/90	Field and lab replicate methods
004	05/90	Monitoring data re-submission
005	05/90	Submitting control charts with QA data
006	05/90	Setting of range check limits
007	08/90	Secchi variability
008	08/90	Data management procedures
009	08/90	Using (SAS) Proc Means in data submission
010	08/90	Inventory of method comparison data
011	08/90	Lowering method detection limits
012	09/90	Criteria for selecting historical data
013	09/90	Data Screening software
014	09/90	Reporting of wind speed (WINDSPD) data
015	12/90	Salinity correction for CBL PO4F data
016	12/90	Blank correction for MDHMH TP/TDP data
017	12/90	Percent recovery calculation methods
018	01/91	Manual injection carbon data (MD mainstem, 6/84-5/15/85)
019	05/91	Field and laboratory methods matrix
020	07/91	Adjustment for ODU TN Kjeldahl data
021	11/91	DOC method comparison study

Issue #	Entry Date	Issue Title
022	11/91	Field data validation/adjustment
023	11/91	PC/PN filter and rinsing study data
024	01/92	Method detection limit (MDL) methods
025	07/92	Water quality/nutrient depth sampling (protocol for mid-water samples/pycnocline calculation)
026	08/92	Revision of analytical problem codes - <i>documentation incomplete</i>
027	10/93	Fluorometric chlorophyll data structure
028	12/96	Problematic chlorophyll values in Virginia tributary data sets
029	12/97	Discrepancy in Maryland data between WQ and Biomonitoring discrete measurements of chlorophyll (affected parameters are CHLA and PHEA)
030		<i>Removed or number not assigned</i>
031	4/94	Submission of Tributary Water Quality data consistent with Mainstem
032	2/96	Virginia Tributary SI and NO23 data
033	3/96	Below Detection Limit
034		<i>Removed or number not assigned</i>
035	2/99	VA Optical Density Data Submission
036	5/99	Downward Facing Light Attenuation Sensor
037	3/99	Chlorophyll Method Comparison and Revision
038	4/03	Light Attenuation Parameter Names and KD Calculation
039	07/05	Variability in station depth
040	06/06	Pycnocline Calculation: Different methods for WQ sample collections and for Designated-Use boundary delineation
041	11/06	Analytical Method Changes in Total Nitrogen Measurements for the Virginia Tributaries <b>Date of</b>
042	09/06	Analytical Method Changes in Total Phosphorus Measurements for the Virginia Tributaries

<b>Issue #</b>	<b>Entry Date</b>	<b>Issue Title</b>
043	06/06	Comparability of parameter estimates from whole water and filtered samples for MD Department of Health and Mental Hygiene data
044	04/08	Secchi hits bottom and is still visible
045	06/08	Investigation of TSS Step Trend at Virginia mainstem stations
046	05/09	Comparison of chlorophyll and pheophytin analyzed at MDHMH and CBL
047		<i>Number reserved</i>
048	01/10	Comparison of TSS samples analyzed using Whatman and Environmental Express filter pads
049	09/10	Comparison of alkaline phenol and salicylate NH4 analysis methods at MDHMH

*Recommended format for submitting issues to DAITS*

***Chesapeake Bay Program Analysis Issues Tracking System***

Issue Tracking Number (assigned by the Water Quality Data Manager):

Category Code (assigned by the Water Quality Data Manager):

Issue Title:

Date of Issue Introduction into the System;

Statement of Issue:

Proposed Solution:

Discussion:

Sense of the Resources Needed to Respond:

Priority Ranking:

Submitter/Responsible Party:

Actions to Date:

Overall Resolution Summary of all Actions:

Recommended Actions:

Actions Number:

This number is an extension of the Issue Number plus .0n, .0n+1 postscript

Example: QA 001.01

1. Designated Respondent:  
(Name/Organization and/or Specific Workgroup)
2. Action:
3. Resources Needed:
4. Due Date:
5. Action Item Resolution Summary:

## Appendix 5

### The CBP Volumetric Interpolator - Analysis and Display tool

The Chesapeake Bay Program three-dimensional, volumetric ‘Interpolator’ was designed with the analysis of water quality monitoring data specifically in mind, although it can be adapted to interpolate other kinds of data as well. The software (Vol3D Version 4.61) and user guide are available online at <https://archive.chesapeakebay.net/Monitoring/Chesapeake%20Bay%20Interpolator/>.

#### Interpolator Conceptual Model

The Interpolator is based on a conceptual 3-dimensional grid consisting of many columns of cells extending from surface to bottom, the number of cells varying, to represent the depth of the water column. Together, the cell grid represents the volume of the Bay and tidal tributaries. In the main Bay grid section, the cells are all one size: 1 km x 1 km in the horizontal direction and 1 m deep. In the tributaries, the cells are 1 m deep, but variable in their horizontal dimensions, depending on the geometry of the tributary. This configuration results in a total of 51,839 cells for the main Bay, and a total of 238,669 cells for the main Bay and tributaries.

The interpolator uses measurement (or point) data collected at fixed points in the grid to estimate values for each cell in the 3-dimensional grid representing the Bay or the Bay and tributaries (see Figure A5-1). For example, if the input observational data come from a CBP Monitoring Program cruise, then the grid will be initially populated with the actual measured values at the midpoints of cells with the coordinates of the stations in the monitoring network at the various depths where the sample measurements were taken. The Interpolator then computes values for all other cell mid-points in the grid by interpolating the nearest neighboring measurements. The interpolator program gives you the option of adjusting the minimum and maximum number of neighbors the interpolator will seek. The default max is 4 and default min is 1. Note that the computed mid-point value represents the interpolated value for the whole cell. The smaller the distance between the actual measurements and the cell midpoints to be estimated, the more accurate the estimated values are likely to be. Thus the denser the station network, the more accurate the interpolator results are likely to be.



Figure A5-1. A schematic illustrating nearest data values (dark circles) in spatial relationship to a grid cell (left) and an example of input measured data values as they might relate to each other in 3-dimensional space (right).

In choosing nearest neighbors for the computation of each cell value, the Interpolator first scans for data at the same depth. There is a limit (which can be modified; the default is 25,000 m) to how far distant the scan will search, and if a measured value is not encountered within this range, then the Interpolator will expand its search up and down to find data at other depths if necessary. The vertical range within which the interpolator will seek measured values is adjustable. The default is 4 m, meaning the interpolator will look 2m up and 2m down in 0.5 m increments (also adjustable) from the center of the cell for which it is attempting to calculate a value. A pre-processing step—vertical interpolation—should be done to preclude the chance that a data value at a nearby site but different depth would be passed over in favor of a more distant data value at the same depth. The input measurement data should be interpolated vertically so that there are values at every 0.5-m interval to ensure that the scan will encounter data from its closest neighbors first. A little more about this is included in the Cautionary Notes section, below.

### Quantitative and Display Applications

The interpolator can be used to estimate concentrations and total mass of the various water quality parameters regionally and basinwide and to display the results in spatial context. The original version ([Reynolds and Bahner 1989](#)) included only the main stem Bay. The next version added the tidal tributaries insofar as available bathymetry information would allow.

The interpolator compensates for differences in volume that different stations represent. For example, if an estimate of a parameter’s average concentration in the Bay were wanted, one could do a simple calculation without the interpolator and average concentrations observed at all the stations. In that case, all stations have equal influence in the answer. The CBP Monitoring Program station network is quite dense, but many stations in the northern shallow part of the Bay represent a smaller number of cells, i.e., a smaller volume, than do the widely separated stations in the deeper lower Bay. The average concentration of all the cells in the grid provides a more representative estimate.

The interpolator has been used in a number of quantitative applications for the CBP. It is best known for estimates of the volume of hypoxic water in the Bay from one year to the next. (Figure A5-2). Hypoxic volume is obtained by summing the volume of all cells with dissolved oxygen concentrations at or below a certain value.

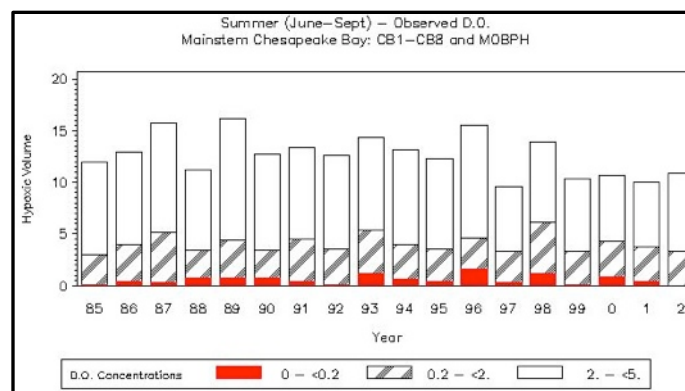

Figure A5-2 shows the volume of anoxic and hypoxic



water in the Bay over time as calculated using the CBP Interpolator.

Figure A5-3 (below) illustrates where, geographically and within the water column, minimum dissolved oxygen concentrations are found in the Bay. It shows conditions in July 2007, just one month in the long time series, but they are typical for the Bay in summer. It is a display of the main Bay only. The tributaries are indicated in gray. The graphic illustrates the interpolator's two modes of display: the plan view and a side view of the center longitudinal transect. The user defines the number, boundary range and color of the scale intervals or can accept the values given by several range files that are included with the interpolator. The color displayed is the color associated with the highest or lowest value of the cells in the line of view. The example graphic is displaying minimum DO concentrations. Thus, for the plan view, the color represents the lowest concentration found in each vertical column of cells. In the side view, the color is the lowest concentration found in each lateral 'column'. Using both the plan and side views, one can see that the deep red color representing severe hypoxia are the grid cells in the bottom half of the water column in the main Bay's deep channel.

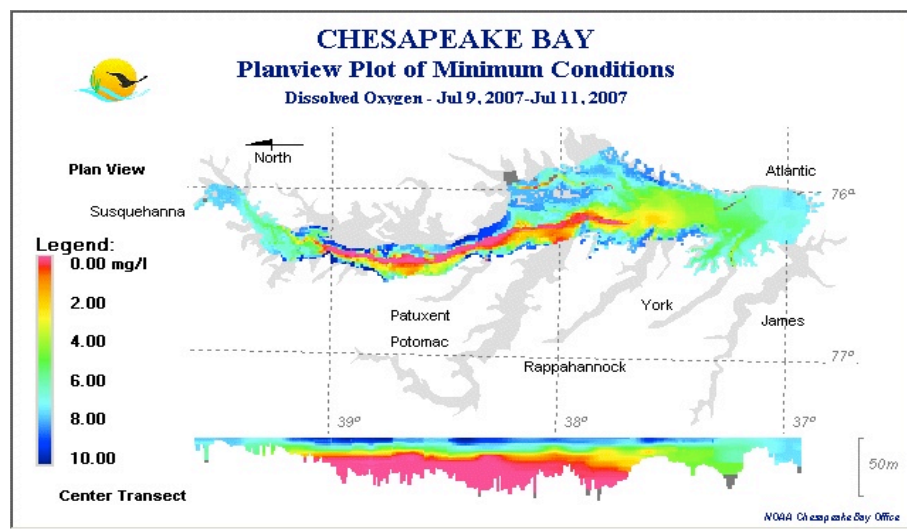

Figure A5-3. Example output from the CBP volumetric interpolator: plan and side views of minimum dissolved oxygen concentrations in main stem Chesapeake Bay

### Cautionary notes

At best, the interpolator is an aid to visualizing the Chesapeake tidal basin in its 3-dimensional aspects and making some general quantitative estimates in this context. There are many aspects of Chesapeake Bay circulation and morphology that the straight-line interpolation does not account for. For example, the interpolator makes some accommodation for the more strongly nonlinear up- and downstream gradients in the tributaries, but that solution is only approximate and it does not account for vertical differences from two-layer flow (freshwater from the watershed overlying brackish water from the ocean), nor the differences in those effects from

inter-annual and seasonal variability in flow. The interpolator program does not account for the barrier vertical exchange that a pycnocline presents. Also, linear interpolation does not recognize the hindrance of a strip of land between two pelagic points. The latter problem has been avoided in a coarse way by including in the software restrictive data region files for each major tributary. The interpolator consults these files to determine if a barrier to exchange exists between two points that would make interpolation between the two points unrealistic. For example, interpolated concentration estimates for cells in the mid Bay region using data from their four nearest neighbors will not include data from Patuxent River stations a bit upstream of the mouth even though, as the crow flies, they may be closer than other main Bay stations. On the other hand, hills and valleys of the Bay and river bottoms that may impact currents and mixing are not accounted for.

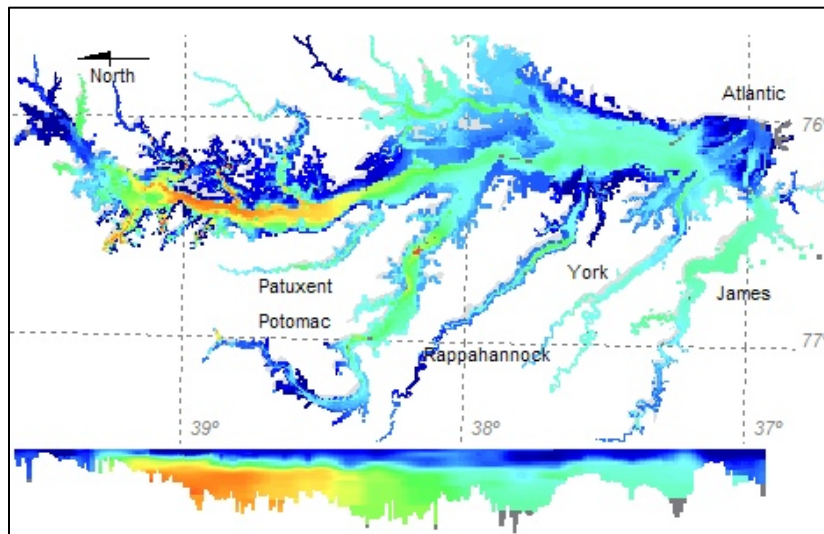

Figure A5-4. Example output from the CBP volumetric interpolator showing main stem Bay and tributaries. Side view of the center transect of the main stem Bay only.

Figure A5-4 (above) is an interpolation including the Bay and tributaries. Note that the side view is of the north-south center transect of the main Bay and does not reflect conditions in the tributaries. Interpolations of a single region, e.g., the lower mainstem Bay or one of the major tributaries are possible, but the graphic displays of the tributaries must be interpreted with extra care. Keeping the cautionary notes in mind, the plan view can be informative. The side views of the tributaries are deceptive, however, since tributaries don't generally have a straight center line that lends itself to upstream-downstream cross-section. They have oxbows and bends that overlap in side view with confusing, uninterpretable results.

Scan the input data to be sure spatial and temporal coverages are appropriate for interpolation

An underlying assumption of the interpolator product as a 'snapshot' is that the point observations that are the basis of the estimates for all the intermediate points in the 3-dimensional grid are collected close enough in time and space to realistically represent conditions in neighboring regions and that one can reasonably assume that points in between are

influenced by or a reflection of those conditions. The 3-day sampling schedule for a full Bay water quality monitoring cruise, for example, already stretches the definition of synchronicity, but it is often operationally impossible or impractical to achieve even this narrow window. Climatic events and operational mishaps within the sampling window can be severe enough to cause big discontinuities between water quality conditions before and after the events.

Theoretically, the best snapshot is obtained by interpolating data from an individual cruise. To characterize conditions for a month or season where two or more sampling cruises were conducted, the best way would be to use the interpolated values for each cell in the grid for each cruise, then to average the values from equivalent cells over the time period. That is not typically the way it is done, however. Usually, to save computational time and difficulty, the observed data are first averaged over the time period, then a single interpolation is done using the averaged point data. The user must decide for himself how to approach it and evaluate the consequences.

The user should consider the effects of regionally different sampling schedules. For example, for many years, Maryland sampled the upper Bay twice in the month of March, while Virginia sampled the lower Bay only once. If the user is interpolating cruise by cruise, then he must know to omit the unmatched, partial cruise. If the user is using the monthly average as the input data, it must be decided whether to omit data from unmatched cruises or to average whatever data are available.

Also, the user should scan the data to be sure that there are not large areas of missing point data in the region of interest. Storms, for example, can sometimes cause a group of stations to be dropped from the cruise schedule. Missing input data may result in stations quite distant from each other qualifying as ‘nearest neighbors’ and contributing to interpolations, with unrealistic or improbable results.

Vertically interpolate the input file before submitting it to the interpolator.

The interpolator uses inverse distance squared of the nearest neighbors to estimate a value for each cell. If, in the input file, the point data at two neighboring monitoring stations are, say at 0.5, 3, 6, and 10 meters, and at 0.5, 4, 7, and 12 meters, then the interpolator will use the values from these ‘neighbors’ (plus another) to estimate values at the 0.5-m depth, but at the 3-m depth, it will search past this neighbor and keep going farther afield until it locates a neighbor with data at the 3-meter node. However, if the user vertically interpolates the station data prior to lateral interpolation, then the interpolator will always encounter a value at his nearest neighbor and can avoid exceeding the distance rule and have to seek a ‘neighbor’ at a different depth. The first version of the Interpolator did a vertical interpolation automatically as the first step before proceeding. The latest version of the interpolator (v4.61) includes an option in the “Data Input” step to perform a vertical interpolation at each station prior to the volumetric interpolation step.

Determine if your application requires that the Bay or Bay-plus-tributaries cells sum to a constant volume.

For example, the hypoxic volume graphic (Fig A5-2), which allows visual comparison of hypoxic volume from one year to the next, does assume that the total volume of the Bay is constant and that annual differences in hypoxic volume and percent-of-total are relative to this

constant volume. That being so, the user must check the input dataset to see that the deepest observation depth at a station is the same from one observation time to the next, or (since this is often not the case) the user must extrapolate from his deepest observation depth to the grid bottom for each sampling event prior to submitting the input dataset to the interpolator.

#### Discrepancies in surface area estimates between the Interpolator and GIS software

There is a discrepancy between surface area estimates of the Bay and tributaries as generated by the CBP interpolator and by GIS software using the same or very similar versions of the segmentation scheme. Overall, the difference in area estimates is only 8.8 %: the total interpolated area= 10,644,320,000 m<sup>2</sup>, the GIS estimate is 11,665,710,065 m<sup>2</sup>, and the ratio of interpolated- to GIS-area (I-G ratio) is 0.912 or 91.2%. However, on a segment basis, the difference as a function of percent of total area can be considerable for many segments (Table A5-1). Users should be careful with applications whose results are in terms of percent segment area and such if they might be compared with other Bay Program GIS-based estimates. Some Criteria Assessments are expressed in these terms.

#### Estimating error

It should be noted that although Chesapeake Bay is extremely well monitored in terms of station density relative to other estuaries, the estuary is extremely large compared to the total number of stations. Assuming a surface area of ~10,600 km<sup>2</sup>, each of the 145 monitoring stations would be representative of ~73 km<sup>2</sup> kilometers assuming that all of the stations were evenly distributed over the entire Bay. This is definitely not the case and some stations will represent less space and most more. In most cases the stations within a given tributary are aligned along its axis, which is good for defining upstream downstream concentration gradients, but not for providing information on conditions along the shoreline. The interpolator will calculate values for these cells but for the most part these values are extrapolations not interpolations. This should be factored into consideration of interpolator output for cells that do not lie between stations.

#### Improvements to the interpolator

There are past and present efforts to create an interpolation tool that addresses these shortcomings and that can be used for purposes requiring quantitative rigor. To date, these efforts have had mixed success. So far, the gain in rigor has been offset by losses in the ease of use for the general user and in the efficiency of handling the vast quantity of data generated by the monitoring program, which is now more than 20 years old. .

Table A5-1. Some statistics concerning area differences between the CBP Interpolator and GIS-based areal calculations.

Pct #Total Segment diff	Cells Segment dim dim to make equal		Pct & vol orig+added	Area cells	E-W required INT area	N-S added to cells	Cell area Volume	#Surf. GIS area
APPTF	100	100	10000	92	920000	151	1510000	8011611
88.5	709.2		82.4					
BACOH	250	250	62500	203	12687500	358	22375000	16175354
21.6	55.8		13.5					
BIGMH	250	250	62500	332	20750000	698	43625000	29067984
28.6	133.1		16.0					
BOHOH	250	250	62500	148	9250000	272	17000000	11927636
22.4	42.8		13.6					
BSHOH	500	500	250000	102	25500000	197	49250000	30542696
16.5	20.2		9.3					
C&DOH	100	100	10000	321	3210000	2413	24130000	3565828
10.0	35.6		1.5					
CB1TF	1000	1000	1000000	132	132000000	360	360000000	151620944
12.9	19.6		5.2					
CB2OH	1000	1000	1000000	270	270000000	1237	1237000000	275239520
1.9	5.2		0.4					
CB3MH	1000	1000	1000000	353	353000000	2391	2391000000	361585728
2.4	8.6		0.4					
CB4MH	1000	1000	1000000	886	886000000	9237	9237000000	908849967
2.5	22.8		0.2					
CB5MH	1000	1000	1000000	1431	1431000000	15416	15416000000	1474652418
3.0	43.7		0.3					
CB6PH	1000	1000	1000000	746	746000000	6503	6503000000	743353039
-0.4	-2.6		-0.0					
CB7PH	1000	1000	1000000	1422	1422000000	13523	13523000000	1520821583
6.5	98.8		0.7					
CB8PH	1000	1000	1000000	399	399000000	3172	3172000000	412427744
3.3	13.4		0.4					
CHKOH	250	250	62500	231	14437500	777	48562500	27969270
48.4	216.5		21.8					
CHOMH1	1000	1000	1000000	211	211000000	945	945000000	242057248
12.8	31.1		3.2					
CHOMH2	500	500	250000	257	64250000	1067	266750000	74200120
13.4	39.8		3.6					
CHOOH	250	250	62500	175	10937500	722	45125000	14477365
24.5	56.6		7.3					
CHOTF	50	50	2500	2238	5595000	6129	15322500	9466475
40.9	1548.6		20.2					
CHSMH	500	500	250000	412	103000000	1821	455250000	119290907
13.7	65.2		3.5					
CHSOH	250	250	62500	175	10937500	462	28875000	14790537
26.1	61.6		11.8					
CHSTF	50	50	2500	707	1767500	1345	3362500	4084016
56.7	926.6		40.8					
CRRMH	250	250	62500	281	17562500	1051	65687500	23483608
25.2	94.7		8.3					
EASMH	500	500	250000	807	201750000	3987	996750000	234558868
14.0	131.2		3.2					
EBEMH	50	50	2500	893	2232500	2584	6460000	5774440
61.3	1416.8		35.4					
ELIMH	100	100	10000	901	9010000	5339	53390000	12203789
26.2	319.4		5.6					
ELIPH	500	500	250000	28	7000000	246	61500000	8948893
21.8	7.8		3.1					
ELKOH	500	500	250000	122	30500000	405	101250000	37270004
18.2	27.1		6.3					

FSBMH	1000	1000	1000000	73	73000000	143	143000000	83505552
12.6	10.5		6.8					
GUNOH	500	500	250000	143	35750000	257	64250000	41998392
14.9	25.0		8.9					
HNGMH	100	100	10000	7281	72810000	18568	185680000	97719184
25.5	2490.9		11.8					
JMSMH	1000	1000	1000000	274	274000000	977	977000000	304241056
9.9	30.2		3.0					
JMSOH	500	500	250000	463	115750000	1726	431500000	127749032
9.4	48.0		2.7					
JMSPH	1000	1000	1000000	66	66000000	434	434000000	76561904
13.8	10.6		2.4					
JMSTF	250	250	62500	932	58250000	4579	286187500	95301848
38.9	592.8		11.5					
LAFMH	100	100	10000	231	2310000	339	3390000	5754146
59.9	344.4		50.4					
LCHMH	500	500	250000	269	67250000	833	208250000	89578958
24.9	89.3		9.7					
LYNPH	100	100	10000	978	9780000	1673	16730000	19607176
50.1	982.7		37.0					
MAGMH	250	250	62500	366	22875000	1224	76500000	26541486
13.8	58.7		4.6					
MANMH	500	500	250000	189	47250000	358	89500000	60788916
22.3	54.2		13.1					
MATTF	250	250	62500	85	5312500	152	9500000	7280895
27.0	31.5		17.2					
MIDOH	250	250	62500	193	12062500	400	25000000	16214070
25.6	66.4		14.2					
MOBPH	500	500	250000	1190	297500000	5370	1342500000	342714372
13.2	180.9		3.3					
MPNOH	100	100	10000	730	7300000	3539	35390000	8660891
15.7	136.1		3.7					
MPNTF	50	50	2500	2122	5305000	6135	15337500	8573187
38.1	1307.3		17.6					

Table A5-1, cont'd. Some statistics concerning area differences between the CBP Interpolator and GIS-based areal calculations

#Total Segment diff	Cells Segment		Pct & vol orig+added	Area cells	E-W required INT area	N-S Cell area added to cells	#Surf. Volume	#Surf. GIS area
	dim to make equal	dim						
NANMH	500	500	250000	163	40750000	389	97250000	48357788
15.7	30.4		7.3					
NANOH	50	50	2500	4746	11865000	18000	45000000	16455330
27.9	1836.1		9.3					
NANTF	50	50	2500	1135	2837500	2646	6615000	4608463
38.4	708.4		21.1					
NORTE	500	500	250000	58	14500000	106	26500000	15817689
8.3	5.3		4.7					
PATMH	500	500	250000	359	89750000	1806	451500000	93604632
4.1	15.4		0.8					
PAXMH	500	500	250000	362	90500000	2244	561000000	107580204
15.9	68.3		3.0					
PAXOH	100	100	10000	986	9860000	2718	27180000	14243456
30.8	438.3		13.9					
PAXTF	50	50	2500	1341	3352500	4410	11025000	4408622
24.0	422.4		8.7					
PIAMH	250	250	62500	782	48875000	3223	201437500	69774176
30.0	334.4		9.4					
PISTF	100	100	10000	276	2760000	285	2850000	3708997
25.6	94.9		25.0					
PMKOH	100	100	10000	1245	12450000	6668	66680000	14093807
11.7	164.4		2.4					
PMKTF	50	50	2500	3465	8662500	11452	28630000	16229024
46.6	3026.6		20.9					
POCMH	500	500	250000	679	169750000	1418	354500000	195923574
13.4	104.7		6.9					
POCOH	50	50	2500	4536	11340000	7200	18000000	13821501
18.0	992.6		12.1					
POCTF	50	50	2500	824	2060000	1788	4470000	3998871
48.5	775.5		30.3					

POTMH	1000	1000	1000000	831	831000000	5792	5792000000	887864640
6.4	56.9		1.0					
POTOH	500	500	250000	804	201000000	3409	852250000	214963696
6.5	55.9		1.6					
POTTF	500	500	250000	548	137000000	1939	484750000	153841616
10.9	67.4		3.4					
RHDMH	250	250	62500	127	7937500	325	20312500	9110563
12.9	18.8		5.5					
RPPMH	500	500	250000	1074	268500000	5929	1482250000	323830688
17.1	221.3		3.6					
RPPOH	100	100	10000	1456	14560000	5358	53580000	19536530
25.5	497.7		8.5					
RPPTF	250	250	62500	441	27562500	1719	107437500	36503308
24.5	143.1		7.7					
SASOH	250	250	62500	421	26312500	1347	84187500	33085712
20.5	108.4		7.4					
SBEMH	100	100	10000	471	4710000	2773	27730000	8393598
43.9	368.4		11.7					
SEVMH	250	250	62500	416	26000000	1815	113437500	29387340
11.5	54.2		2.9					
SOUMH	250	250	62500	329	20562500	1072	67000000	23982120
14.3	54.7		4.9					
TANMH	1000	1000	1000000	814	814000000	4019	4019000000	897937605
9.3	83.9		2.0					
WBEMH	100	100	10000	315	3150000	631	6310000	6006832
47.6	285.7		31.2					
WICMH	100	100	10000	2741	27410000	5642	56420000	35116516
21.9	770.7		12.0					
WSTMH	250	250	62500	144	9000000	326	20375000	11303989
20.4	36.9		10.2					
YRKMH	500	500	250000	301	75250000	1102	275500000	94595793
20.5	77.4		6.6					
YRKPH	500	500	250000	229	57250000	1603	400750000	68414728
16.3	44.7		2.7					